

# Pioneer

## Service Manual

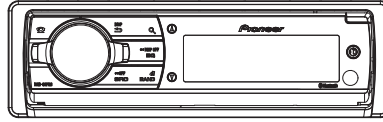

DEH-80PRS/XNUC

ORDER NO.  
**CRT4866**

CD RDS RECEIVER

# DEH-80PRS /XNUC

## DEH-80PRS /XNEW5

## DEH-80PRS /XNES

This service manual should be used together with the following manual(s):

Model No.	Order No.	Mech. Module	Remarks
CX-3287	CRT4759	S11.6STD	CD Mech. Module : Circuit Descriptions, Mech. Descriptions, Disassembly



**PIONEER CORPORATION** 1-1, Shin-ogura, Saiwai-ku, Kawasaki-shi, Kanagawa 212-0031, Japan  
**PIONEER ELECTRONICS (USA) INC.** P.O. Box 1760, Long Beach, CA 90801-1760, U.S.A.  
**PIONEER EUROPE NV** Haven 1087, Keetberglaan 1, 9120 Melsele, Belgium  
**PIONEER ELECTRONICS ASIACENTRE PTE. LTD.** 253 Alexandra Road, #04-01, Singapore 159936  
©PIONEER CORPORATION 2012

K-ZZZ FEB. 2012 Printed in Japan

# SAFETY INFORMATION

## **CAUTION**

This service manual is intended for qualified service technicians; it is not meant for the casual do-it-yourselfer. Qualified technicians have the necessary test equipment and tools, and have been trained to properly and safely repair complex products such as those covered by this manual. Improperly performed repairs can adversely affect the safety and reliability of the product and may void the warranty. If you are not qualified to perform the repair of this product properly and safely, you should not risk trying to do so and refer the repair to a qualified service technician.

## **WARNING**

This product may contain a chemical known to the State of California to cause cancer, or birth defects or other reproductive harm.

Health & Safety Code Section 25249.6 - Proposition 65

Where in a manufacturer's service documentation, for example in circuit diagrams or lists of components, a symbol is used to indicate that a specific component shall be replaced only by the component specified in that documentation for safety reasons, the following symbol shall be used:



### ● Safety Precautions for those who Service this Unit.

When checking or adjusting the emitting power of the laser diode exercise caution in order to get safe, reliable results.

### Caution:

1. During repair or tests, minimum distance of 13 cm from the focus lens must be kept.
2. During repair or tests, do not view laser beam for 10 seconds or longer.

### **CAUTION:**

**USE OF CONTROLS OR ADJUSTMENTS OR PERFORMANCE OF PROCEDURES OTHER THAN THOSE SPECIFIED HEREIN MAY RESULT IN HAZARDOUS RADIATION EXPOSURE.**

### **CAUTION**

This product is a class 1 laser product classified under the Safety of laser products, IEC 60825-1:2007, and contains a class 1M laser module. To ensure continued safety, do not remove any covers or attempt to gain access to the inside of the product. Refer all servicing to qualified personnel.

**CLASS 1 LASER PRODUCT**

**CAUTION—CLASS 1M INVISIBLE LASER  
RADIATION WHEN OPEN. DO NOT VIEW  
DIRECTLY WITH OPTICAL INSTRUMENTS.**

### **WARNING!**

The AEL (accessible emission level) of the laser power output is less than CLASS 1 but the laser component is capable of emitting radiation exceeding the limit for CLASS 1.

A specially instructed person should do servicing operation of the apparatus.

**Laser diode characteristics**

Wave length : 785 nm to 814 nm

Maximum output : 1 190  $\mu$ W(Emitting period : unlimited)

**Additional Laser Caution**

Transistors Q101 in PCB drive the laser diodes.

When Q101 is shorted between their terminals, the laser diodes will radiate beam.

If the top cover is removed with no disc loaded while such short-circuit is continued, the naked eyes may be exposed to the laser beam.

**CAUTION**

Danger of explosion if battery is incorrectly replaced.

Replaced only with the same or equivalent type recommended by the manufacturer.

Discard used batteries according to the manufacturer's instructions.

# CONTENTS

	SAFETY INFORMATION.....	2
	1. SERVICE PRECAUTIONS.....	5
A	1.1 SERVICE PRECAUTIONS.....	5
	1.2 NOTES ON SOLDERING.....	6
	2. SPECIFICATIONS.....	7
	2.1 SPECIFICATIONS.....	7
	2.2 DISC/CONTENT FORMAT.....	13
	3. BASIC ITEMS FOR SERVICE.....	14
	3.1 CHECK POINTS AFTER SERVICING.....	14
	3.2 PCB LOCATIONS.....	14
	3.3 JIGS LIST.....	15
	3.4 CLEANING.....	15
	4. BLOCK DIAGRAM.....	16
	5. DIAGNOSIS.....	20
B	5.1 OPERATIONAL FLOWCHART.....	20
	5.2 ERROR CODE LIST.....	21
	5.3 CONNECTOR FUNCTION DESCRIPTION.....	24
	6. SERVICE MODE.....	25
	6.1 DISPLAY TEST MODE.....	25
	6.2 CD TEST MODE.....	28
	7. DISASSEMBLY.....	29
	8. EACH SETTING AND ADJUSTMENT.....	33
	8.1 CD ADJUSTMENT.....	33
	8.2 CHECKING THE GRATING AFTER CHANGING THE PICKUP UNIT.....	34
	8.3 PCL OUTPUT CONFIRMATION.....	36
C	9. EXPLODED VIEWS AND PARTS LIST.....	38
	9.1 PACKING.....	38
	9.2 EXTERIOR.....	42
	9.3 CD MECHANISM MODULE.....	44
	10. SCHEMATIC DIAGRAM.....	46
	10.1 TUNER AMP UNIT (SYSTEM BLOCK) (GUIDE PAGE).....	46
	10.2 TUNER AMP UNIT (MEDIA BLOCK) (GUIDE PAGE).....	52
	10.3 TUNER AMP UNIT (DSP BLOCK) (GUIDE PAGE).....	58
	10.4 TUNER AMP UNIT (POWER SUPPLY BLOCK) (GUIDE PAGE).....	64
	10.5 KEYBOARD UNIT.....	70
	10.6 CD CORE UNIT (S11.6STD).....	72
	10.7 PANEL UNIT.....	74
	10.8 WAVEFORMS.....	75
D	11. PCB CONNECTION DIAGRAM.....	78
	11.1 TUNER AMP UNIT.....	78
	11.2 KEYBOARD UNIT.....	82
	11.3 CD CORE UNIT (S11.6STD).....	84
	11.4 PANEL UNIT.....	86
	12. ELECTRICAL PARTS LIST.....	87

E

F

# 1. SERVICE PRECAUTIONS

## 1.1 SERVICE PRECAUTIONS



1. You should conform to the regulations governing the product (safety, radio and noise, and other regulations), and should keep the safety during servicing by following the safety instructions described in this manual.
2. Before disassembling the unit, be sure to turn off the power. Unplugging and plugging the connectors during power-on mode may damage the ICs inside the unit.
3. To protect the pickup unit from electrostatic discharge during servicing, take an appropriate treatment (shorting-solder) by referring to "the DISASSEMBLY".
4. After replacing the pickup unit, be sure to check the grating.
5. Be careful in handling ICs. Some ICs such as MOS type are so fragile that they can be damaged by electrostatic induction.
6.  area and a heat sink becomes hot areas. Be careful not to burn yourself.

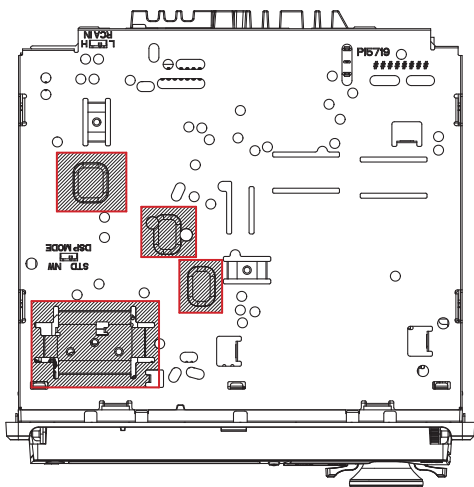

7. The RESET button is at the back of the Detach Grille.  
Note that the audio settings cannot be deleted by a hard reset.  
Reset the audio settings from the initial setting menu.
8. Be careful not to damage the Knob for the Slide Switches (S351, S601) at the bottom of the Tuner Amp Unit while handling it or attaching the Bottom Plate.
9. The part listed below is difficult to replace as a discrete component part.  
When the part listed in the table is defective, replace whole Assy.

TUNER AMP UNIT	IC851	LT1912EMSE	Heat pad
----------------	-------	------------	----------

10. RGB LED's (D1831 - D1864) are used for the illumination of the Keyboard Unit. To avoid the color heterogeneity, replace the whole of the Keyboard Unit, even if only one of RGB LED's was defective.

## 1.2 NOTES ON SOLDERING

- For environmental protection, lead-free solder is used on the printed circuit boards mounted in this unit.

A Be sure to use lead-free solder and a soldering iron that can meet specifications for use with lead-free solders for repairs accompanied by reworking of soldering.

- Compared with conventional eutectic solders, lead-free solders have higher melting points, by approximately 40°C. Therefore, for lead-free soldering, the tip temperature of a soldering iron must be set to around 373°C in general, although the temperature depends on the heat capacity of the PC board on which reworking is required and the weight of the tip of the soldering iron.

Compared with eutectic solders, lead-free solders have higher bond strengths but slower wetting times and higher melting temperatures (hard to melt/easy to harden).

The following lead-free solders are available as service parts:

- Parts numbers of lead-free solder:

B GYP1006 1.0 in dia.  
GYP1007 0.6 in dia.  
GYP1008 0.3 in dia.

C

D

E

F

# 2. SPECIFICATIONS

## 2.1 SPECIFICATIONS

### • DEH-80PRS/XNUC

#### General

Power source.....	14.4 V DC (10.8 V to 15.1 V allowable)
Grounding system.....	Negative type
Maximum current consumption .....	10.0 A
Backup current .....	5.0 mA or less
Dimensions (W × H × D):	
DIN	
Chassis .....	178 mm × 50 mm × 165 mm (7 in. × 2 in. × 6-1/2 in.)
Nose .....	188 mm × 58 mm × 17 mm (7-3/8 in. × 2-1/4 in. × 5/8 in.)
D	
Chassis .....	178 mm × 50 mm × 165 mm (7 in. × 2 in. × 6-1/2 in.)
Nose .....	170 mm × 46 mm × 17 mm (6-3/4 in. × 1-3/4 in. × 5/8 in.)
Weight .....	1.2 kg (2.6 lbs)

#### Audio

Maximum power output .....	50 W × 4
Continuous power output ...	22 W × 4 (50 Hz to 15 000 Hz, 5 % THD, 4 Ω load, both channels driven)
Load impedance .....	4 Ω to 8 Ω × 4
Preout maximum output level .....	5.0 V
Loudness contour .....	+10 dB (100 Hz), +6.5 dB (10 kHz) (volume: -30 dB)
Equalizer (Left/Right independent 16-Band Graphic Equalizer):	
Frequency.....	20 Hz/31.5 Hz/50 Hz/80 Hz/125 Hz/200 Hz/315 Hz/500 Hz/800 Hz/1.25 kHz/2 kHz/3.15 kHz/5 kHz/8 kHz/12.5 kHz/20 kHz
Equalization range .....	±12 dB (2 dB step)
Auto equalizer:	
(Front & rear & subwoofer/High & mid & low)	
Frequency.....	20 Hz/31.5 Hz/50 Hz/80 Hz/125 Hz/200 Hz/315 Hz/500 Hz/800 Hz/1.25 kHz/2 kHz/3.15 kHz/5 kHz/8 kHz/12.5 kHz/20 kHz
Equalization range .....	+6 dB to -12 dB (2 dB step)
Network (standard mode):	
HPF (front)	
Frequency.....	50 Hz/63 Hz/80 Hz/100 Hz/125 Hz/160 Hz/200 Hz

Slope.....	0 (Pass)/-6 dB/oct./-12 dB/oct.
Gain .....	0 dB to -24 dB/Mute (1 dB step)
HPF (rear)	
Frequency.....	50 Hz/63 Hz/80 Hz/100 Hz/125 Hz/160 Hz/200 Hz
Slope.....	0 (Pass)/-6 dB/oct./-12 dB/oct.
Gain .....	+6 dB to -24 dB/Mute (1 dB step)
Subwoofer (stereo/mono):	
Frequency.....	50 Hz/63 Hz/80 Hz/100 Hz/125 Hz/160 Hz/200 Hz
Slope.....	-6 dB/oct./-12 dB/oct./-18 dB/oct.
Gain .....	+6 dB to -24 dB/Mute (1 dB step)
Phase .....	Normal/Reverse
Network (3-way network mode):	
High HPF:	
Frequency.....	1.25 kHz/1.6 kHz/2 kHz/2.5 kHz/3.15 kHz/4 kHz/5 kHz/6.3 kHz/8 kHz/10 kHz/12.5 kHz
Slope.....	-6 dB/oct./-12 dB/oct./-18 dB/oct./-24 dB/oct.
Gain .....	0 dB to -24 dB/Mute (1 dB step)
Phase .....	Normal/Reverse
Mid HPF/LPF:	
Frequency (LPF)...	1.25 kHz/1.6 kHz/2 kHz/2.5 kHz/3.15 kHz/4 kHz/5 kHz/6.3 kHz/8 kHz/10 kHz/12.5 kHz
Frequency (HPF) .....	25 Hz/31.5 Hz/40 Hz/50 Hz/63 Hz/80 Hz/100 Hz/125 Hz/160 Hz/200 Hz/250 Hz
Slope (LPF).....	0 (Pass)/-6 dB/oct./-12 dB/oct./-18 dB/oct./-24 dB/oct.
Slope (HPF).....	0 (Pass)/-6 dB/oct./-12 dB/oct./-18 dB/oct./-24 dB/oct.
Gain .....	0 dB to -24 dB/Mute (1 dB step)
Phase .....	Normal/Reverse
Low LPF (stereo/mono):	
Frequency.....	25 Hz/31.5 Hz/40 Hz/50 Hz/63 Hz/80 Hz/100 Hz/125 Hz/160 Hz/200 Hz/250 Hz
Slope.....	-12 dB/oct./-18 dB/oct./-24 dB/oct./-30 dB/oct./-36 dB/oct.

A

Gain ..... +6 dB to -24 dB/Mute (1 dB step)  
Phase ..... Normal/Reverse

Usable sensitivity..... 9 dBf (0.8  $\mu$ V/75  $\Omega$ , mono, S/N: 30 dB)  
Signal-to-noise ratio..... 72 dB (IHF-A network)

### CD player

System ..... Compact disc audio system  
Usable discs ..... Compact disc  
Signal-to-noise ratio..... 105 dB (1 kHz) (IHF-A network)  
Number of channels ..... 2 (stereo)  
MP3 decoding format ..... MPEG-1 & 2 Audio Layer 3  
WMA decoding format ..... Ver. 7, 7.1, 8, 9, 10, 11, 12 (2 ch audio) (Windows Media Player)  
AAC decoding format..... MPEG-4 AAC (iTunes encoded only) (.m4a) (Ver. 10.4 and earlier)  
WAV signal format ..... Linear PCM & MS ADPCM (Non-compressed)

### AM tuner

Frequency range..... 530 kHz to 1 710 kHz  
Usable sensitivity..... 25  $\mu$ V (S/N: 20 dB)  
Signal-to-noise ratio..... 62 dB (IHF-A network)

### Bluetooth

Version ..... Bluetooth 3.0 certified  
Output power ..... +4 dBm Maximum (Power class 2)

B

### CEA2006 Specifications



Power output ..... 14 W RMS  $\times$  4 Channels (4  $\Omega$  and  $\leq$  1 % THD+N)  
S/N ratio ..... 91 dBA (reference: 1 W into 4  $\Omega$ )

### USB

USB standard specification ..... USB 2.0 full speed  
Maximum current supply .... 1 A  
USB Class..... MSC (Mass Storage Class)  
File system..... FAT12, FAT16, FAT32  
MP3 decoding format ..... MPEG-1 & 2 Audio Layer 3  
WMA decoding format ..... Ver. 7, 7.1, 8, 9, 10, 11, 12 (2 ch audio) (Windows Media Player)  
AAC decoding format..... MPEG-4 AAC (iTunes encoded only) (.m4a) (Ver. 10.4 and earlier)  
WAV signal format ..... Linear PCM & MS ADPCM (Non-compressed)

### Note

Specifications and the design are subject to modifications without notice.

D

### SD

Compatible physical format ..... Version 2.00  
Maximum memory capacity ..... 32 GB (for SD and SDHC)  
File system..... FAT12, FAT16, FAT32  
MP3 decoding format ..... MPEG-1 & 2 Audio Layer 3  
WMA decoding format ..... Ver. 7, 7.1, 8, 9, 10, 11, 12 (2 ch audio) (Windows Media Player)  
AAC decoding format..... MPEG-4 AAC (iTunes encoded only) (.m4a) (Ver. 10.4 and earlier)  
WAV signal format ..... Linear PCM & MS ADPCM (Non-compressed)

E

### FM tuner

Frequency range..... 87.9 MHz to 107.9 MHz

F



## • DEH-80PRS/XNEW5

### General

Power source.....	14.4 V DC (10.8 V to 15.1 V allowable)
Grounding system.....	Negative type
Maximum current consumption	
.....	10.0 A
Backup current .....	5.0 mA or less
Dimensions (W × H × D):	
DIN	
Chassis .....	178 mm × 50 mm × 165 mm
Nose .....	188 mm × 58 mm × 17 mm
D	
Chassis .....	178 mm × 50 mm × 165 mm
Nose .....	170 mm × 46 mm × 17 mm
Weight .....	1.2 kg

### Audio

Maximum power output .....	50 W × 4
Continuous power output ...	22 W × 4 (50 Hz to 15 000 Hz, 5 % THD, 4 Ω load, both channels driven)
Load impedance .....	4 Ω to 8 Ω × 4
Preout maximum output level	
.....	5.0 V
Loudness contour .....	+10 dB (100 Hz), +6.5 dB (10 kHz) (volume: -30 dB)
Equalizer (Left/Right independent 16-Band Graphic Equalizer):	
Frequency.....	20 Hz/31.5 Hz/50 Hz/80 Hz/125 Hz/200 Hz/315 Hz/500 Hz/800 Hz/1.25 kHz/2 kHz/3.15 kHz/5 kHz/8 kHz/12.5 kHz/20 kHz
Equalization range.....	±12 dB (2 dB step)
Auto equalizer:	
(Front & rear & subwoofer/High & mid & low)	
Frequency.....	20 Hz/31.5 Hz/50 Hz/80 Hz/125 Hz/200 Hz/315 Hz/500 Hz/800 Hz/1.25 kHz/2 kHz/3.15 kHz/5 kHz/8 kHz/12.5 kHz/20 kHz
Equalization range.....	+6 dB to -12 dB (2 dB step)
Network (standard mode):	
HPF (front)	
Frequency.....	50 Hz/63 Hz/80 Hz/100 Hz/125 Hz/160 Hz/200 Hz
Slope .....	0 (Pass)/-6 dB/oct./-12 dB/oct.
Gain .....	0 dB to -24 dB/Mute (1 dB step)

HPF (rear)	
Frequency.....	50 Hz/63 Hz/80 Hz/100 Hz/125 Hz/160 Hz/200 Hz
Slope .....	0 (Pass)/-6 dB/oct./-12 dB/oct.
Gain .....	+6 dB to -24 dB/Mute (1 dB step)

Subwoofer (stereo/mono):	
Frequency.....	50 Hz/63 Hz/80 Hz/100 Hz/125 Hz/160 Hz/200 Hz
Slope .....	-6 dB/oct./-12 dB/oct./-18 dB/oct.
Gain .....	+6 dB to -24 dB/Mute (1 dB step)
Phase .....	Normal/Reverse

### Network (3-way network mode):

High HPF:	
Frequency.....	1.25 kHz/1.6 kHz/2 kHz/2.5 kHz/3.15 kHz/4 kHz/5 kHz/6.3 kHz/8 kHz/10 kHz/12.5 kHz
Slope .....	-6 dB/oct./-12 dB/oct./-18 dB/oct./-24 dB/oct.
Gain .....	0 dB to -24 dB/Mute (1 dB step)
Phase .....	Normal/Reverse

Mid HPF/LPF:	
Frequency (LPF)...	1.25 kHz/1.6 kHz/2 kHz/2.5 kHz/3.15 kHz/4 kHz/5 kHz/6.3 kHz/8 kHz/10 kHz/12.5 kHz

Frequency (HPF)	
.....	25 Hz/31.5 Hz/40 Hz/50 Hz/63 Hz/80 Hz/100 Hz/125 Hz/160 Hz/200 Hz/250 Hz
Slope (LPF).....	0 (Pass)/-6 dB/oct./-12 dB/oct./-18 dB/oct./-24 dB/oct.
Slope (HPF).....	0 (Pass)/-6 dB/oct./-12 dB/oct./-18 dB/oct./-24 dB/oct.
Gain .....	0 dB to -24 dB/Mute (1 dB step)
Phase .....	Normal/Reverse

Low LPF (stereo/mono):	
Frequency.....	25 Hz/31.5 Hz/40 Hz/50 Hz/63 Hz/80 Hz/100 Hz/125 Hz/160 Hz/200 Hz/250 Hz
Slope .....	-12 dB/oct./-18 dB/oct./-24 dB/oct./-30 dB/oct./-36 dB/oct.
Gain .....	+6 dB to -24 dB/Mute (1 dB step)
Phase .....	Normal/Reverse

A

**CD player**

System .....	Compact disc audio system
Usable discs .....	Compact disc
Signal-to-noise ratio .....	105 dB (1 kHz) (IEC-A network)
Number of channels .....	2 (stereo)
MP3 decoding format .....	MPEG-1 & 2 Audio Layer 3
WMA decoding format .....	Ver. 7, 7.1, 8, 9, 10, 11, 12 (2 ch audio) (Windows Media Player)
AAC decoding format .....	MPEG-4 AAC (iTunes encoded only) (.m4a) (Ver. 10.4 and earlier)
WAV signal format .....	Linear PCM & MS ADPCM (Non-compressed)

**USB**

USB standard specification .....	USB 2.0 full speed
Maximum current supply ....	1 A
USB Class .....	MSC (Mass Storage Class)
File system .....	FAT12, FAT16, FAT32
MP3 decoding format .....	MPEG-1 & 2 Audio Layer 3
WMA decoding format .....	Ver. 7, 7.1, 8, 9, 10, 11, 12 (2 ch audio) (Windows Media Player)
AAC decoding format .....	MPEG-4 AAC (iTunes encoded only) (.m4a) (Ver. 10.4 and earlier)
WAV signal format .....	Linear PCM & MS ADPCM (Non-compressed)

**SD**

Compatible physical format .....	Version 2.00
Maximum memory capacity .....	32 GB (for SD and SDHC)
File system .....	FAT12, FAT16, FAT32
MP3 decoding format .....	MPEG-1 & 2 Audio Layer 3
WMA decoding format .....	Ver. 7, 7.1, 8, 9, 10, 11, 12 (2 ch audio) (Windows Media Player)
AAC decoding format .....	MPEG-4 AAC (iTunes encoded only) (.m4a) (Ver. 10.4 and earlier)
WAV signal format .....	Linear PCM & MS ADPCM (Non-compressed)

**FM tuner**

Frequency range .....	87.5 MHz to 108.0 MHz
Usable sensitivity .....	9 dBf (0.8 $\mu$ V/75 $\Omega$ , mono, S/N: 30 dB)
Signal-to-noise ratio .....	72 dB (IEC-A network)

**MW tuner**

Frequency range .....	531 kHz to 1 602 kHz
Usable sensitivity .....	25 $\mu$ V (S/N: 20 dB)
Signal-to-noise ratio .....	62 dB (IEC-A network)

**LW tuner**

Frequency range .....	153 kHz to 281 kHz
Usable sensitivity .....	28 $\mu$ V (S/N: 20 dB)
Signal-to-noise ratio .....	62 dB (IEC-A network)

**Bluetooth**

Version .....	Bluetooth 3.0 certified
Output power .....	+4 dBm Maximum (Power class 2)

**Note**

Specifications and the design are subject to modifications without notice.

F

## • DEH-80PRS/XNES

### General

Rated power source.....	14.4 V DC (allowable voltage range: 12.0 V to 14.4 V DC)
Grounding system.....	Negative type
Maximum current consumption	10.0 A
Backup current .....	5.0 mA or less
Dimensions (W × H × D):	
DIN	
Chassis .....	178 mm × 50 mm × 165 mm
Nose .....	188 mm × 58 mm × 17 mm
D	
Chassis .....	178 mm × 50 mm × 165 mm
Nose .....	170 mm × 46 mm × 17 mm
Weight .....	1.2 kg

### Audio

Maximum power output .....	50 W × 4
Continuous power output ...	22 W × 4 (50 Hz to 15 000 Hz, 5 % THD, 4 Ω load, both channels dri- ven)
Load impedance .....	4 Ω to 8 Ω × 4
Preout maximum output level	5.0 V
Loudness contour .....	+10 dB (100 Hz), +6.5 dB (10 kHz) (volume: -30 dB)
Equalizer (Left/Right independent 16-Band Graphic Equalizer):	
Frequency.....	20 Hz/31.5 Hz/50 Hz/80 Hz/ 125 Hz/200 Hz/315 Hz/ 500 Hz/800 Hz/1.25 kHz/ 2 kHz/3.15 kHz/5 kHz/8 kHz/ 12.5 kHz/20 kHz
Equalization range .....	±12 dB (2 dB step)
Auto equalizer:	
(Front & rear & subwoofer/High & mid & low)	
Frequency.....	20 Hz/31.5 Hz/50 Hz/80 Hz/ 125 Hz/200 Hz/315 Hz/ 500 Hz/800 Hz/1.25 kHz/ 2 kHz/3.15 kHz/5 kHz/8 kHz/ 12.5 kHz/20 kHz
Equalization range .....	+6 dB to -12 dB (2 dB step)
Network (standard mode):	
HPF (front)	
Frequency.....	50 Hz/63 Hz/80 Hz/100 Hz/ 125 Hz/160 Hz/200 Hz
Slope .....	0 (Pass)/-6 dB/oct./-12 dB/ oct.

Gain .....	0 dB to -24 dB/Mute (1 dB step)
HPF (rear)	
Frequency.....	50 Hz/63 Hz/80 Hz/100 Hz/ 125 Hz/160 Hz/200 Hz
Slope .....	0 (Pass)/-6 dB/oct./-12 dB/ oct.
Gain .....	+6 dB to -24 dB/Mute (1 dB step)
Subwoofer (stereo/mono):	
Frequency.....	50 Hz/63 Hz/80 Hz/100 Hz/ 125 Hz/160 Hz/200 Hz
Slope .....	-6 dB/oct./-12 dB/oct./- 18 dB/oct.
Gain .....	+6 dB to -24 dB/Mute (1 dB step)
Phase .....	Normal/Reverse
Network (3-way network mode):	
High HPF:	
Frequency.....	1.25 kHz/1.6 kHz/2 kHz/ 2.5 kHz/3.15 kHz/4 kHz/ 5 kHz/6.3 kHz/8 kHz/10 kHz/ 12.5 kHz
Slope .....	-6 dB/oct./-12 dB/oct./- 18 dB/oct./-24 dB/oct.
Gain .....	0 dB to -24 dB/Mute (1 dB step)
Phase .....	Normal/Reverse
Mid HPF/LPF:	
Frequency (LPF)...	1.25 kHz/1.6 kHz/2 kHz/ 2.5 kHz/3.15 kHz/4 kHz/ 5 kHz/6.3 kHz/8 kHz/10 kHz/ 12.5 kHz
Frequency (HPF)	
.....	25 Hz/31.5 Hz/40 Hz/50 Hz/ 63 Hz/80 Hz/100 Hz/125 Hz/ 160 Hz/200 Hz/250 Hz
Slope (LPF).....	0 (Pass)/-6 dB/oct./-12 dB/ oct./-18 dB/oct./-24 dB/oct.
Slope (HPF).....	0 (Pass)/-6 dB/oct./-12 dB/ oct./-18 dB/oct./-24 dB/oct.
Gain .....	0 dB to -24 dB/Mute (1 dB step)
Phase .....	Normal/Reverse
Low LPF (stereo/mono):	
Frequency.....	25 Hz/31.5 Hz/40 Hz/50 Hz/ 63 Hz/80 Hz/100 Hz/125 Hz/ 160 Hz/200 Hz/250 Hz
Slope .....	-12 dB/oct./-18 dB/oct./- 24 dB/oct./-30 dB/oct./- 36 dB/oct.
Gain .....	+6 dB to -24 dB/Mute (1 dB step)
Phase .....	Normal/Reverse

A

**CD player**

System .....	Compact disc audio system
Usable discs .....	Compact disc
Signal-to-noise ratio .....	105 dB (1 kHz) (IEC-A network)
Number of channels .....	2 (stereo)
MP3 decoding format .....	MPEG-1 & 2 Audio Layer 3
WMA decoding format .....	Ver. 7, 7.1, 8, 9, 10, 11, 12 (2 ch audio) (Windows Media Player)
AAC decoding format .....	MPEG-4 AAC (iTunes encoded only) (.m4a) (Ver. 10.4 and earlier)
WAV signal format .....	Linear PCM & MS ADPCM (Non-compressed)

B

**USB**

USB standard specification .....	USB 2.0 full speed
Maximum current supply ....	1 A
USB Class .....	MSC (Mass Storage Class)
File system .....	FAT12, FAT16, FAT32
MP3 decoding format .....	MPEG-1 & 2 Audio Layer 3
WMA decoding format .....	Ver. 7, 7.1, 8, 9, 10, 11, 12 (2 ch audio) (Windows Media Player)
AAC decoding format .....	MPEG-4 AAC (iTunes encoded only) (.m4a) (Ver. 10.4 and earlier)
WAV signal format .....	Linear PCM & MS ADPCM (Non-compressed)

C

**SD**

Compatible physical format .....	Version 2.00
Maximum memory capacity .....	32 GB (for SD and SDHC)
File system .....	FAT12, FAT16, FAT32
MP3 decoding format .....	MPEG-1 & 2 Audio Layer 3
WMA decoding format .....	Ver. 7, 7.1, 8, 9, 10, 11, 12 (2 ch audio) (Windows Media Player)
AAC decoding format .....	MPEG-4 AAC (iTunes encoded only) (.m4a) (Ver. 10.4 and earlier)
WAV signal format .....	Linear PCM & MS ADPCM (Non-compressed)

D

E

**FM tuner**

Frequency range .....	87.5 MHz to 108.0 MHz
Usable sensitivity .....	9 dBf (0.8 $\mu$ V/75 $\Omega$ , mono, S/N: 30 dB)
Signal-to-noise ratio .....	72 dB (IEC-A network)

F

**AM tuner**

Frequency range .....	531 kHz to 1 602 kHz (9 kHz) 530 kHz to 1 640 kHz (10 kHz)
Usable sensitivity .....	25 $\mu$ V (S/N: 20 dB)
Signal-to-noise ratio .....	62 dB (IEC-A network)

**Note**

Specifications and the design are subject to modifications without notice.

## Fastening the front panel

If you do not plan to detach the front panel, the front panel can be fastened with supplied screws and holders.

- 1 Attach the holders to both sides of the front panel.

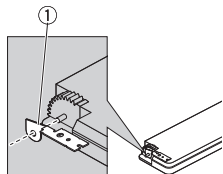

- ① Holder : CND1249, CND1250 (UC)  
Holder : CXX1644, CXX1645 (EW5, ES)

- 2 Replace the front panel to the unit.

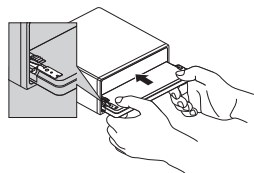

- 3 Flip the holders into upright positions.

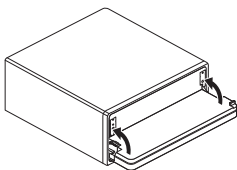

- 4 Fix the front panel to the unit using fixing screws.

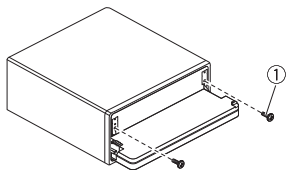

- ① Screw : BPZ20P060FTC (UC)  
Screw : XXX7020 (EW5, ES)

## 2.2 DISC/CONTENT FORMAT



The Bluetooth word mark and logos are owned by the Bluetooth SIG, Inc. and any use of such marks by Pioneer Corporation is under license. Other trademarks and trade names are those of their respective owners.



# 3. BASIC ITEMS FOR SERVICE

## 3.1 CHECK POINTS AFTER SERVICING

To keep the product quality after servicing, please confirm following check points.

No.		Procedures	Item to be confirmed
1		Confirm whether the customer complain has been solved. If the customer complain occurs with the specific media, use it for the operation check.	The customer complain must not be reappeared. Display, audio and operations must be normal.
2	CD	Play back a CD. (Track search)	No malfunction on display, audio and operation.
3	FM/AM tuner	Check FM/AM tuner action. (Seek, Preset) Switch band to check both FM and AM.	Display, audio and operations must be normal.
4		Check whether no disc is inside the product.	The media used for the operating check must be ejected.
5		Appearance check	No scratches or dirt on its appearance after receiving it for service.

See the table below for the items to be checked regarding audio:

Item to be checked regarding audio
Distortion
Noise
Volume too low
Volume too high
Volume fluctuating
Sound interrupted

## 3.2 PCB LOCATIONS

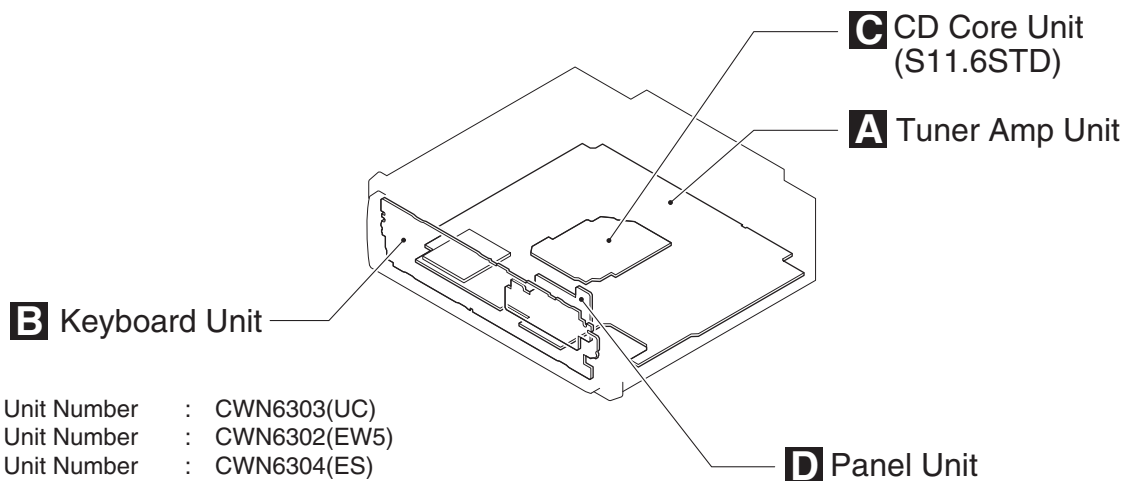

- Unit Number : CWN6303(UC)
- Unit Number : CWN6302(EW5)
- Unit Number : CWN6304(ES)
- Unit Name : Tuner Amp Unit
- Unit Number : (UC,ES)
- Unit Number : (EW5)
- Unit Name : Keyboard Unit
- Unit Number : CWX4023
- Unit Name : CD Core Unit (S11.6STD)
- Unit Number : CWN6306
- Unit Name : Panel Unit

### 3.3 JIGS LIST

#### ● Jigs List

Name	Jig No.	Remarks
16P FFC	GGD1310	Tuner Amp Unit - CD Core Unit
Test Disc	TCD-782	Checking the grating
L.P.F.		Checking the grating (Two pieces)
Acetate Tape	GYH1026	Capacitor Bond Lock

#### ● Grease List

Name	Grease No.	Remarks
Grease	GEM1024	CD Mechanism Module
Grease	GEM1043	CD Mechanism Module
Grease	GEM1013	Panel Assy
Silicon Glue	GEM1017	Capacitor Bond Lock

### 3.4 CLEANING



Before shipping out the product, be sure to clean the following portions by using the prescribed cleaning tools:

Portions to be cleaned	Cleaning tools
CD pickup lenses	Cleaning liquid : GEM1004 Cleaning paper : GED-008

# 4. BLOCK DIAGRAM

## A TUNER AMP UNIT(1/2)

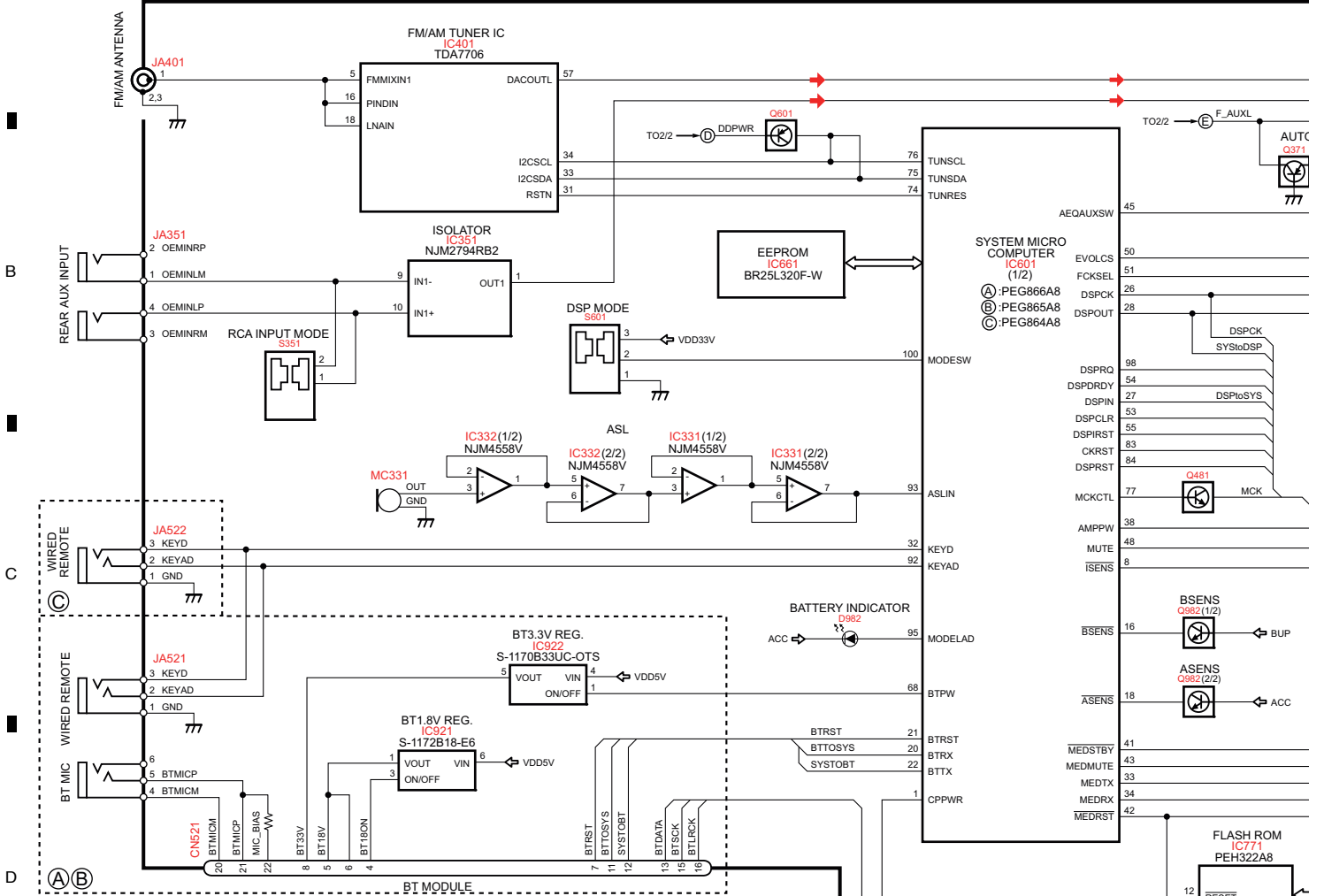

## PICKUP UNIT (P10.6)(SERVICE)

## C CD CORE UNIT(S11.6 STD)

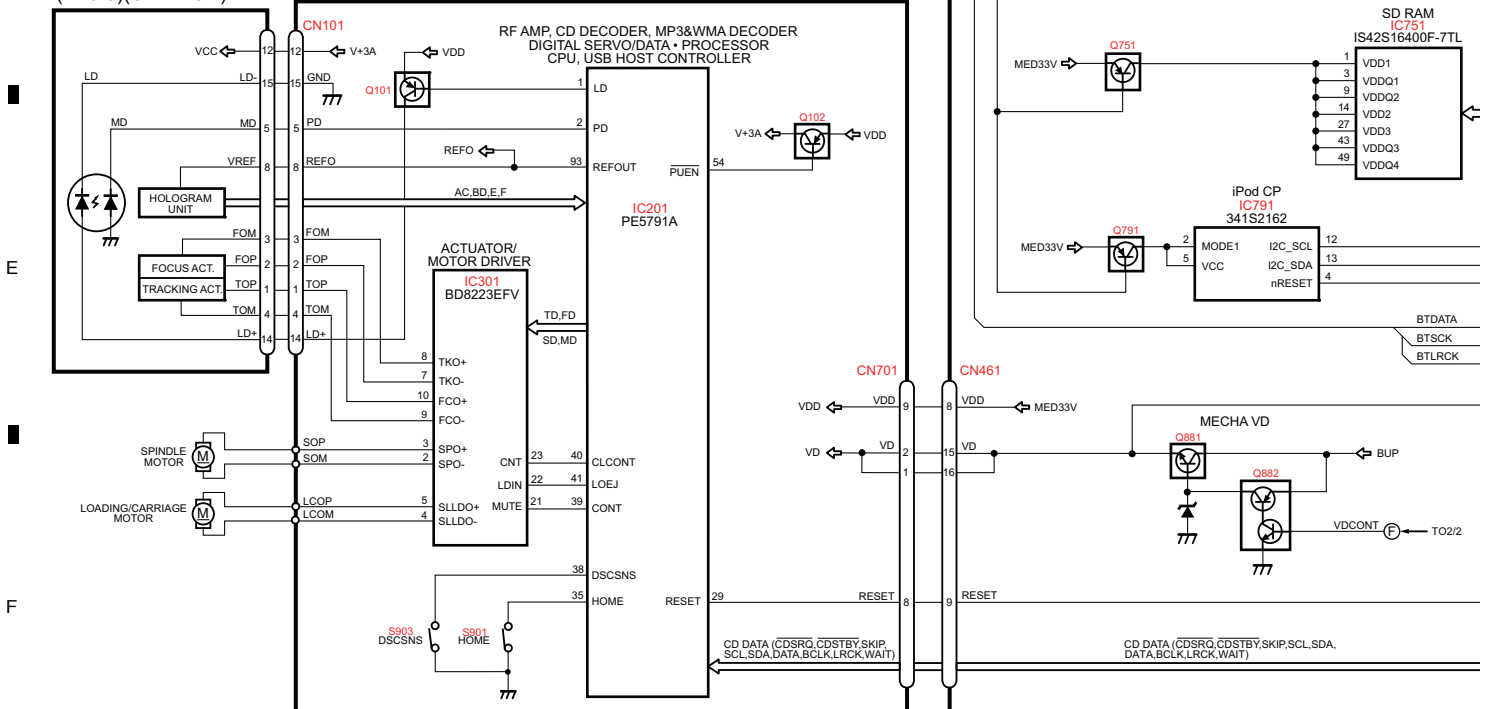



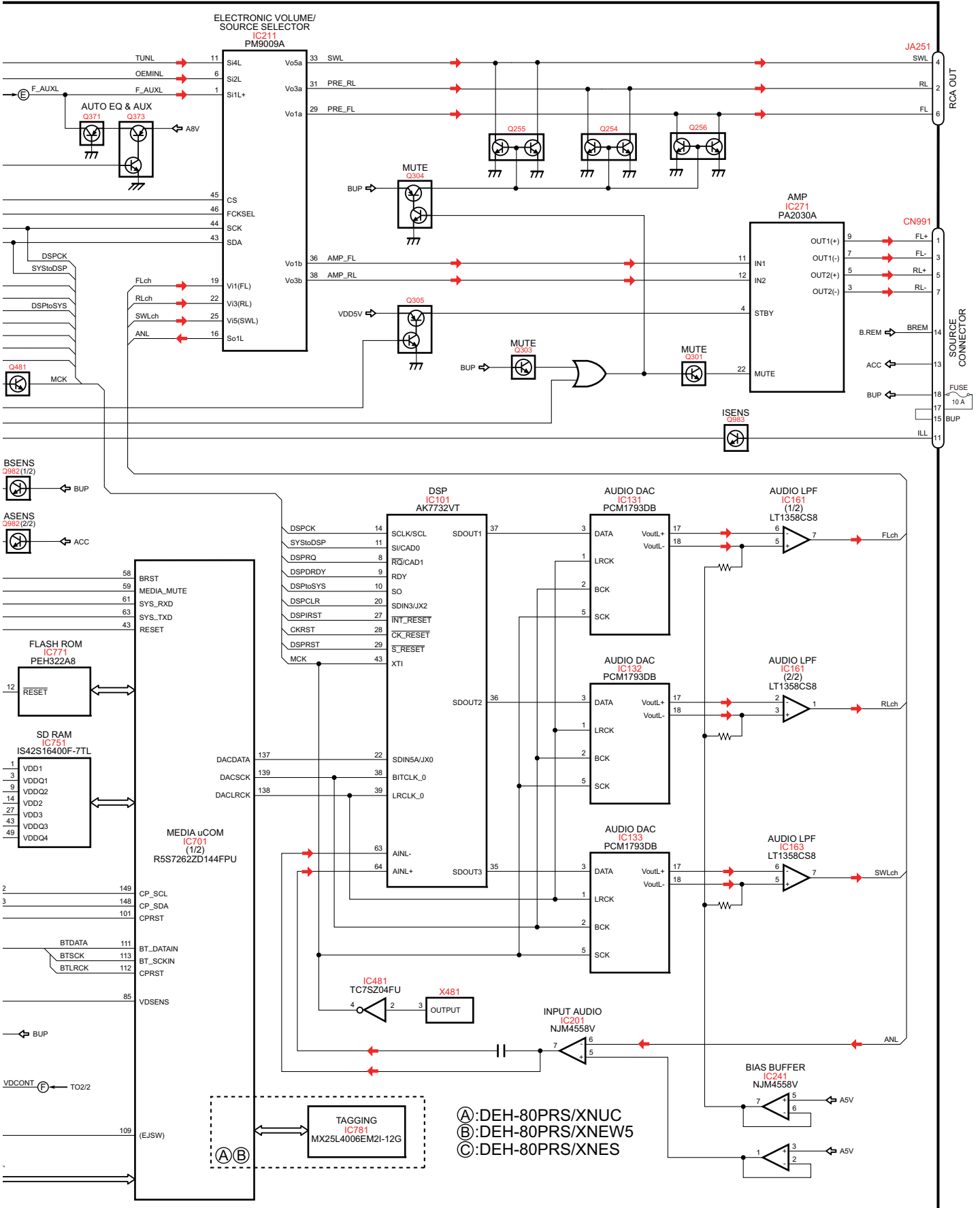

(A): DEH-80PRS/XNUC  
 (B): DEH-80PRS/XNEW5  
 (C): DEH-80PRS/XNES

# A TUNER AMP UNIT(2/2)

# D

A

B

C

D

E

F

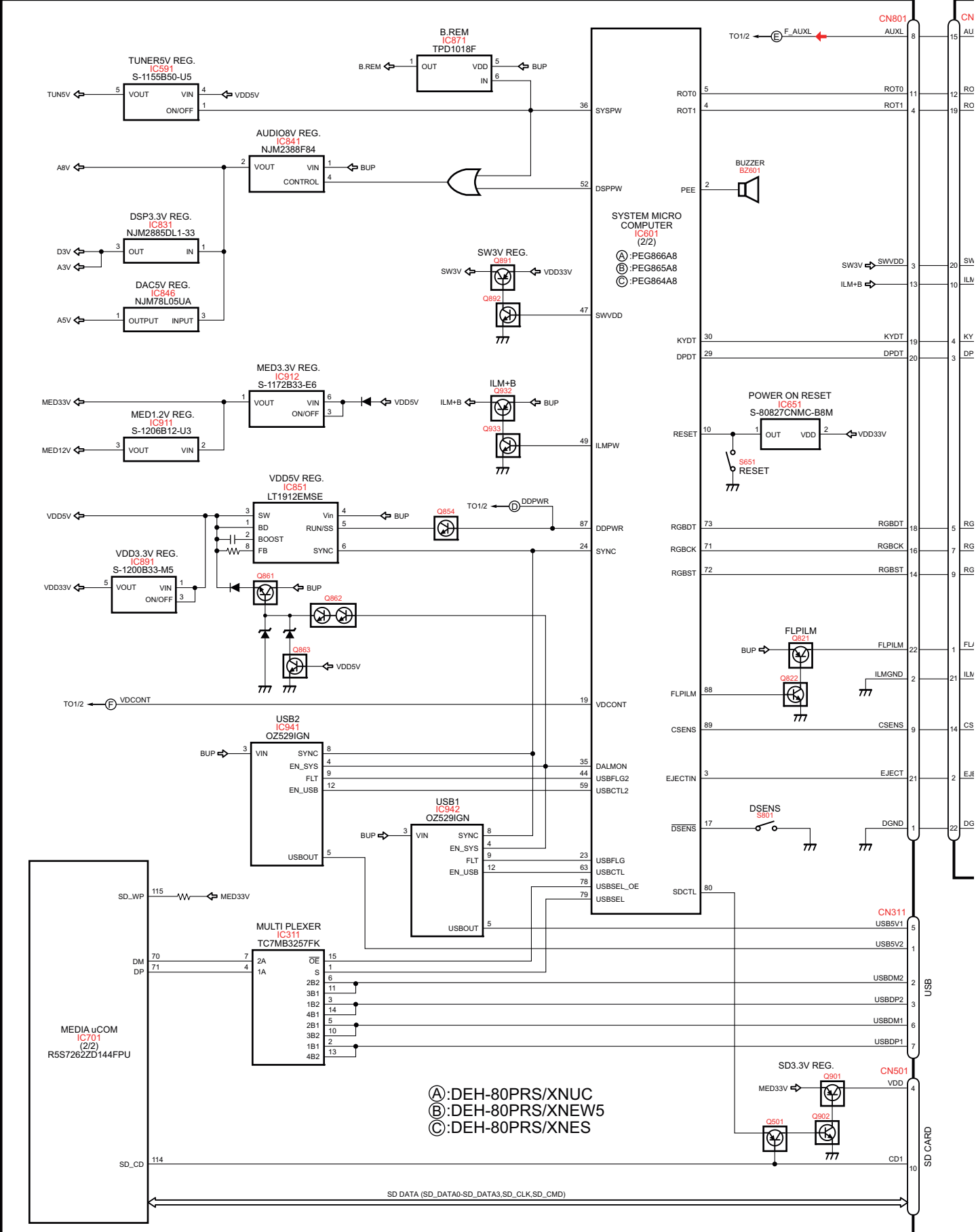

- Ⓐ:DEH-80PRS/XNUC
- Ⓑ:DEH-80PRS/XNEW5
- Ⓒ:DEH-80PRS/XNES

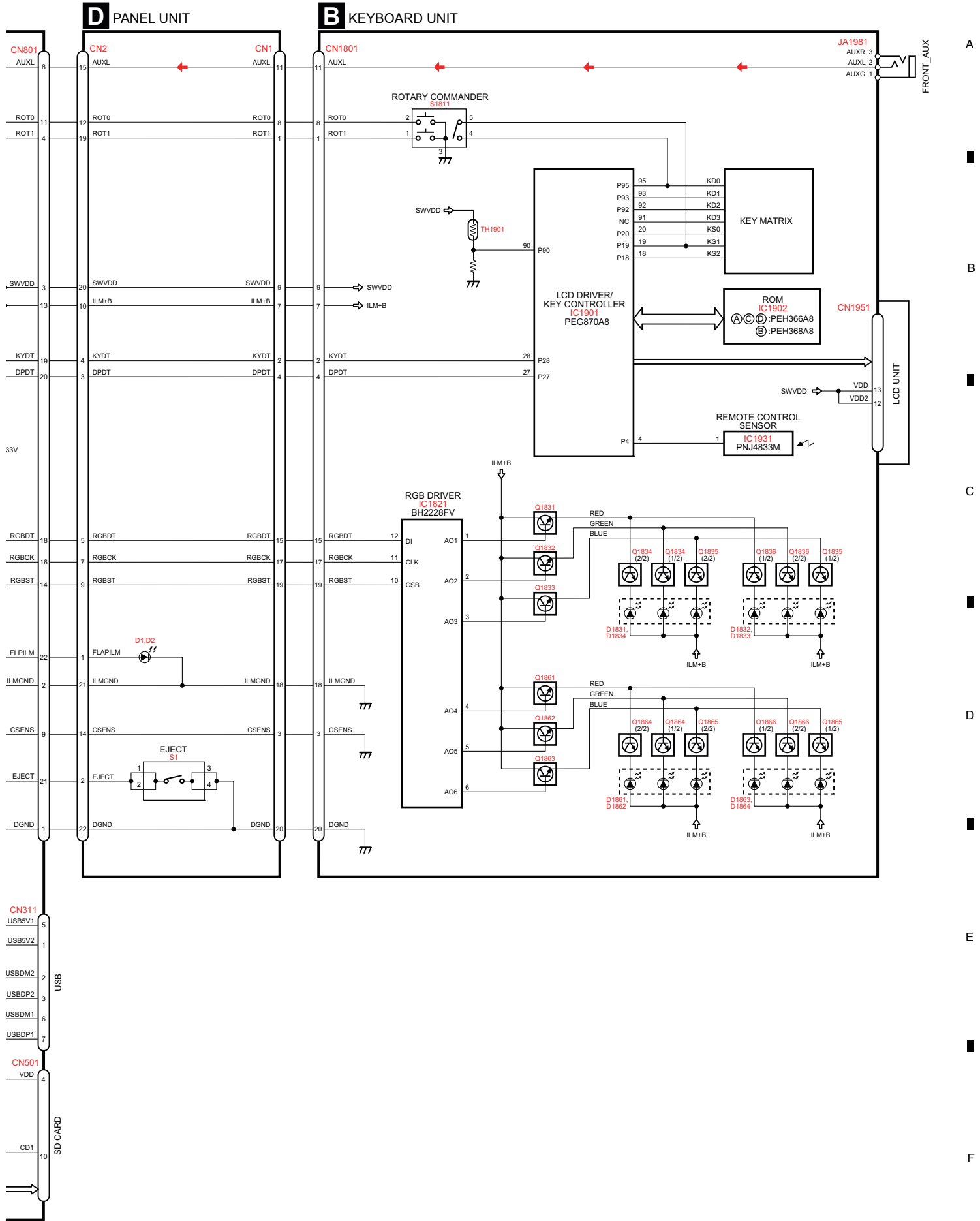

# 5. DIAGNOSIS

## 5.1 OPERATIONAL FLOWCHART

A

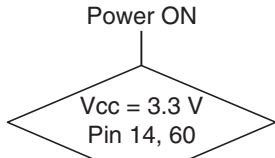

$\overline{\text{BSENS}} = \text{L}$

B



$\overline{\text{ASENS}} = \text{L}$



$\overline{\text{DSENS}} = \text{L}$

C



$1.3 \text{ V} < \text{CSENS} < 2 \text{ V}$

●  $1.3 \text{ V} < \text{CSENS} < 2 \text{ V}$   
 Last source returns.  
 CD loading functions are available.  
 Keys except for EJECT key are not available.

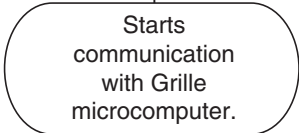

D

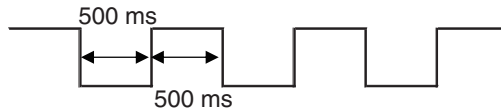
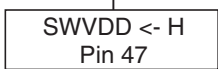

In case of the above signal, the communication with Grille microcomputer may fail.  
 If the time interval is not 500 msec, the oscillator may be defective.

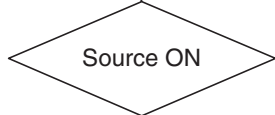
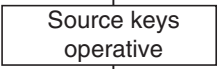

E

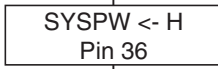

Completes power-on operation.  
 (After that, proceed to each source operation)

F

## 5.2 ERROR CODE LIST

### Error Code

The error status occurs when CD/USB/SD cannot operate, or stop during operation due to an error.  
The reason for such error is displayed with a numeral.

This intends to reduce the number of nonsense calls from users and to assist in analysis/repair in services.

#### 1. Basic display method

An error status (F0h) is entered in the Media status area of the source concerned, and the code in the minute/second area for notification.

E.g. For Read Error

Media status (disc) = 0xF0h

Minute (upper): FFh

Minute (lower): 07h

Second: 07h

- As for VD ERROR, the error status shall be 0xFB.

- Example of head unit display

The following occurs depending on the LCD display capability. The error No. comes in xx.

\* For OEM, the error shall be displayed as per the specification of the OEM destination.

Display in 8 digits	Display in 6 digits	Display in 4 digits
ERROR-xx	ERR-xx	E-xx

#### 2. List of error status codes

Code	Source	Error status	Details and reasons
07h	CD	Read_Error	The CD mecha cannot read the Disc TOC The TOC section of the PRD/Disc has been damaged
10h	CD	Carriage Home NG	The CRG of the CD mecha cannot move to the inner perimeter The CRG of the CD mecha cannot move from the inner perimeter => Failure in the HOME SWITCH of the CD mecha. Failure in CRG movement. Failure in communication between the microcomputer and servo LSI.
11h	CD	Focus_Error (Focus Error in mechanism set up)	The CD mecha cannot take focus. Dirt on the back of the disc and CD-RW. Significant vibration.
12h	CD	Spindle Rock, ID/SubCode Read Error/RF AMP NG	No spindle lock occurs in the CD mecha. No sub-code can be read. No appropriate RF AMP gain is set up. => Failure in the spindle. Scratches or dirt on the disc. Significant vibration. CD-R with no written content. Occasionally the back of the disc. CD signal abnormality.
15h	CD	RF NG	Failed to read RF -> CD-R with no written content. CD-RW with no written content.
17h	CD	Setup NG	The AGC protection does not work. Easily become out of focus. => Scratches or dirt on the disc. Significant vibration. CD-RW
23h	CD	File Format NG	Written in the incompatible file format. => The CD-ROM recorded in a file format other than ISO 9660 Level 1 or 2 has been set (e.g.UDF).
	USB	File Format NG	Written in the incompatible file format. => Recorded in a file format other than FAT 12/16/32
	SD	File Format NG	Written in the incompatible file format. => Recorded in a file format other than FAT 12/16/32
30h	CD	Search Time Out	The CD mecha could not reach the target address => Failure in the CRG or tracking. Scratches on the disc
50h	CD	Loading_Ejecting_Mecha_Error	Disc LoadNG/EjectNG Foreign object inserted in the mecha. Disc stuck.
16h	USB	Unsuccessful authentication of iPod	Unsuccessful authentication of iPod (this occurs only with iPod) => In case authentication is attempted again and an error is turned back from the iPod or authentication IC during iPod authentication
18h	USB	Incompatible device	Incompatible device connection detected => In case something other than mass storage or iPod is connected In case incompatible iPod is connected. Or in case the connected iPod is compatible but has an incompatible firmware version.
	SD	Incompatible device	Incompatible card connected detected (e.g. incompatible MMC) etc.
22h	CD	Not playable	No playable file The CD-ROM set has no MP3, WMA, AAC or WAV file.
	USB	Not playable	No playable file The USB device set has no MP3, WMA, AAC or WAV file.
	SD	Not playable	No playable file The SD card set has not MP3, WMA, AAC or WAV file.
24h	CD	All DRM	All playable files in the disc are DRM.
	USB	All DRM	All playable files in the device are DRM.
	SD	All DRM	All playable files in the SD card are DRM.
19h	USB	Communication error	Cannot communicate with the device => In case the device failure or other reason prevents communication
	SD	Communication error	Cannot communicate with the SD card => In case the SD card failure or other reason prevents communication

A External storage device (USB, SD)/iPod

Message	Cause	Action
<b>NO DEVICE</b>	No USB storage device or iPod is connected.	Connect a compatible USB storage device/iPod.
<b>FORMAT READ</b>	Sometimes there is a delay between the start of playback and when you start to hear any sound.	Wait until the message disappears and you hear sound.
<b>NO AUDIO</b>	There are no songs.	Transfer the audio files to the USB storage device and connect.
	The connected USB storage device has security enabled.	Follow the USB storage device instructions to disable the security.
<b>SKIPPED</b>	The connected USB storage device contains files embedded with Windows Media™ DRM 9/10.	Play an audio file not embedded with Windows Media DRM 9/10.
<b>PROTECT</b>	All the files in the USB storage device are embedded with Windows Media DRM 9/10.	Transfer audio files not embedded with Windows Media DRM 9/10 to the USB storage device and connect.
<b>NOT COMPATIBLE</b>	The USB device connected to is not supported by this unit.	<ul style="list-style-type: none"> <li>• Connect a USB Mass Storage Class compliant device.</li> <li>• Disconnect your device and replace it with a compatible USB storage device.</li> </ul>
	Non-compatible iPod	Disconnect your device and replace it with a compatible iPod.
	Non-compatible SD storage device	Remove your device and replace it with a compatible SD storage device.

Message	Cause	Action
<b>CHECK USB</b>	The USB connector or USB cable has short-circuited.	Check that the USB connector or USB cable is not caught in something or damaged.
	The connected USB storage device consumes more than maximum allowable current.	Disconnect the USB storage device and do not use it. Turn the ignition switch to OFF, then to ACC or ON and then connect only compliant USB storage devices.
	The iPod operates correctly but does not charge.	Make sure the connection cable for the iPod has not shorted out (e.g., not caught in metal objects). After checking, turn the ignition switch OFF and back ON, or disconnect the iPod and reconnect.
<b>ERROR-19</b>	Communication failed.	<ul style="list-style-type: none"> <li>• Perform one of the following operations. <ul style="list-style-type: none"> <li>–Turn the ignition switch OFF and back ON.</li> <li>–Disconnect or eject the external storage device.</li> <li>–Change to a different source.</li> </ul> </li> <li>• Disconnect the cable from the USB or SD source.</li> <li>• Disconnect the cable from the iPod. Once the iPod's main menu is displayed, reconnect the iPod and reset it.</li> </ul>
	iPod failure.	Disconnect the cable from the iPod. Once the iPod's main menu is displayed, reconnect the iPod and reset it.

E

F

Message	Cause	Action
<b>ERROR-23</b>	USB storage device was not formatted with FAT12, FAT16 or FAT32.	USB storage device should be formatted with FAT12, FAT16 or FAT32.
<b>ERROR-16</b>	The iPod firmware version is old. iPod failure.	Update the iPod version. Disconnect the cable from the iPod. Once the iPod's main menu is displayed, reconnect the iPod and reset it.
<b>STOP</b>	There are no songs in the current list.	Select a list that contains songs.
<b>Not found</b>	No related songs.	Transfer songs to the iPod.

#### Bluetooth device

Message	Cause	Action
<b>ERROR-10</b>	The power failed for the Bluetooth module of this unit.	Turn the ignition switch OFF and then to ACC or ON. If the error message is still displayed after performing the above action, please contact your dealer or an authorized Pioneer Service Station.

#### Pandora

Message	Cause	Action
<b>ERROR-19</b>	Communication failed.	Disconnect the cable from the iPod. Once the iPod's main menu is displayed, reconnect the iPod and reset it.
<b>Start up the Pandora Application</b>	The Pandora application has not started running yet.	Start up the Pandora application from your iPod/iPhone.

Message	Cause	Action
<b>Try again later</b>	Unable to save thumb rating. Unable to save BookMark. Pandora system is undergoing maintenance.	Try again later.
<b>Skip limit reached</b>	Skip limit reached.	Do not exceed the skip limit.
<b>Check Application</b>	This version of the Pandora application is not supported.	Connect an iPod/iPhone that has a compatible version of the Pandora application installed.
<b>Check Device</b>	Device error message displayed in Pandora Application. Unable to play music from Pandora.	Please check your iPod/iPhone.
<b>No Available Station</b>	No station found.	Create a station in the Pandora application on your iPod/iPhone.
<b>No Active Stations</b>	No station selected.	Select a station.

#### Auto TA and EQ

Message	Cause	Action
<b>ERR:MIC check</b>	The microphone is not connected.	Plug the supplied microphone securely into the jack.
<b>ERR:Front Speaker,ERR:Front-Lch,ERR:Front-Rch,ERR:Rear-Lch,ERR:Rear-Rch,ERR:SubW-Lch,ERR:SubW-Rch,ERR:SubWoofer</b>	The microphone cannot pick up the measuring tone of a speaker.	<ul style="list-style-type: none"> <li>• Confirm that the speakers are connected correctly.</li> <li>• Cancel muting the front speaker units.</li> <li>• Correct the input level setting of the power amp connected to the speakers.</li> <li>• Set the microphone correctly.</li> </ul>
<b>ERR:Outside Noise</b>	The surrounding noise level is too high.	<ul style="list-style-type: none"> <li>• Stop your car in a place that is quiet, and switch off the engine, air conditioner and heater.</li> <li>• Set the microphone correctly.</li> </ul>

# 5.3 CONNECTOR FUNCTION DESCRIPTION

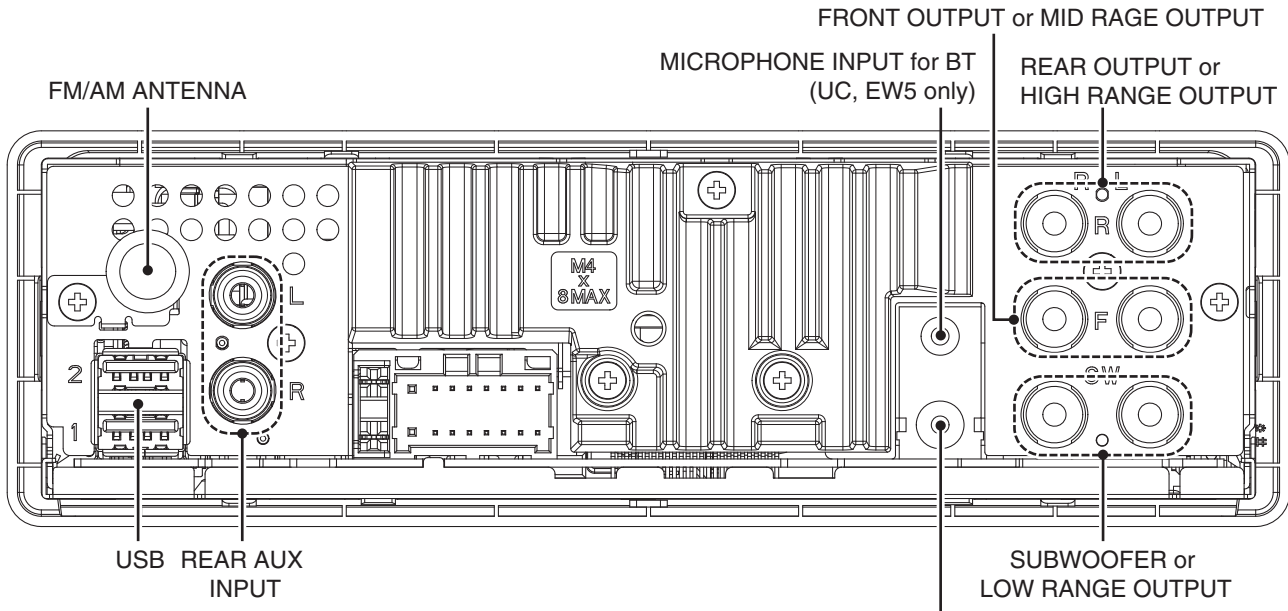

15	13	11	9	7	5	3	1
16	14	12	10	8	6	4	2

- |       |          |
|-------|----------|
| 1 FL+ | 9 NC     |
| 2 FR+ | 10 NC    |
| 3 FL- | 11 ILL   |
| 4 FR- | 12 NC    |
| 5 RL+ | 13 ACC   |
| 6 RR+ | 14 B.REM |
| 7 RL- | 15 B.UP  |
| 8 RR- | 16 GND   |



# 6. SERVICE MODE

## 6.1 DISPLAY TEST MODE

### Service Display Test Mode

#### 1. Overview

This is the test mode which summarized the confirmation of the system microcomputer version and the all light ON/OFF functions of a display part.

#### 2. Operation method

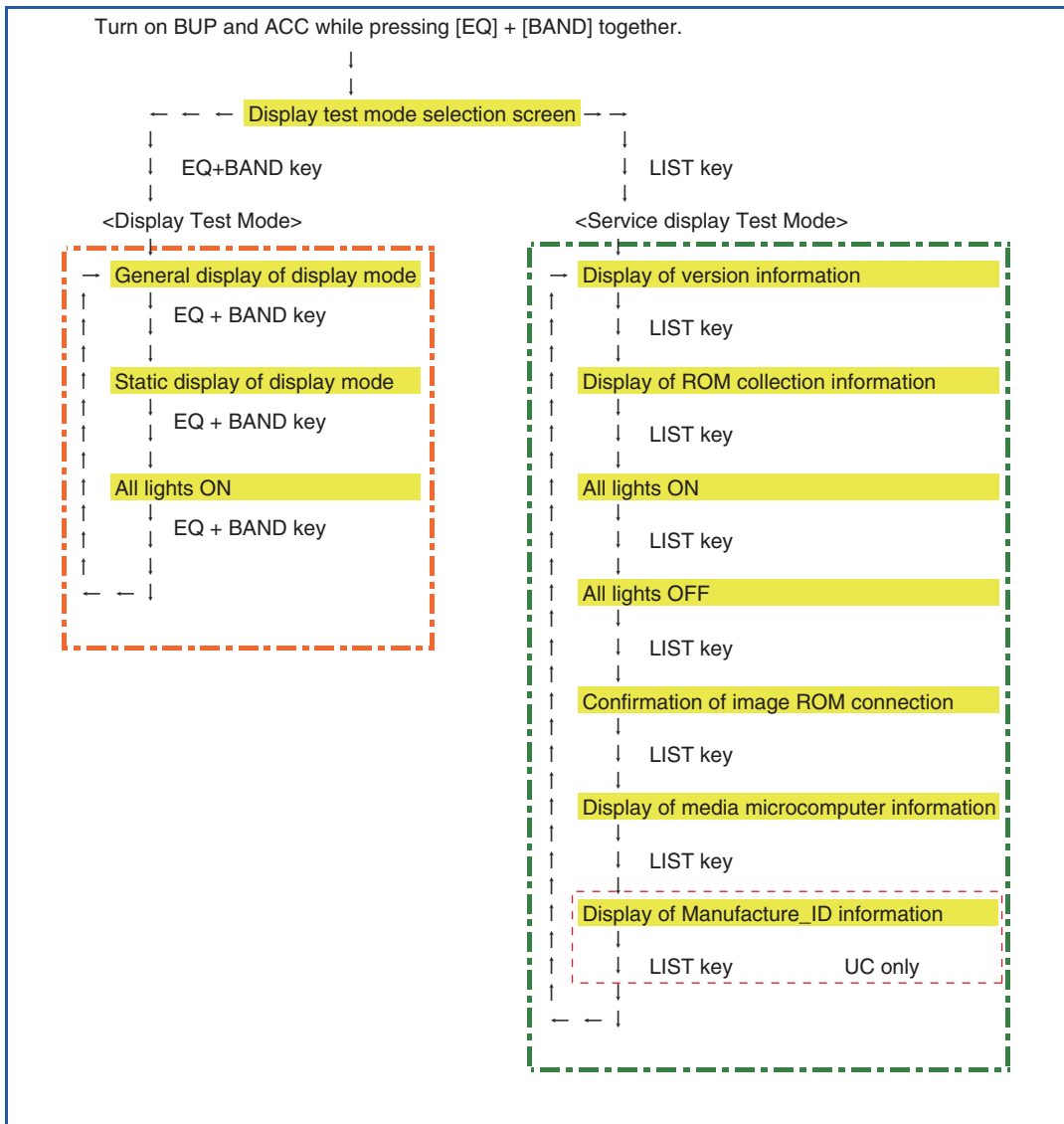

A 3. Contents to be displayed

Display test mode selection screen  
Manual Flap model

0	8	16	24	32	40	48	56	64	72	80	88	96	04	12	20	28	36	44	52	60	68	76	84	92
8	TEST - Mode Select -																							
16																								
24	DISPLAY : EQ + BAND																							
32																								
40	SERVICE : LIST																							
48																								

All lights ON

0	8	16	24	32	40	48	56	64	72	80	88	96	04	12	20	28	36	44	52	60	68	76	84	92
8	[All cells lit]																							
16	[All cells lit]																							
24	[All cells lit]																							
32	[All cells lit]																							
40	[All cells lit]																							
48	[All cells lit]																							

- If nothing appears on the screen:  
There might be a problem in communication or abnormality in the display microcomputer.
- If noise appears on the screen:  
There might be abnormality in the display microcomputer or a problem, for instance, in connection between the display microcomputer and the OEL driver.

C

Display of version information

0	8	16	24	32	40	48	56	64	72	80	88	96	04	12	20	28	36	44	52	60	68	76	84	92
8	I C I n f o .																							
16	- - - - -																							
24	P D V e r U N I T																							
32	S Y S * * * * * * . * * ○ ? ? ? ?																							
40	D I S # # # # # # . # # ○ & & &																							
48	P I C ! ! ! ! ! ! . ! !																							

Description:  
UNIT  
????:The unit number information of the system microcomputer  
&&&&:The unit number information of the display microcomputer  
Display the four-digit number only.  
(For CWW1969, display 1969)

D

Display of ROM collection information

(1) If no information could be acquired from EEPROM

0	8	16	24	32	40	48	56	64	72	80	88	96	04	12	20	28	36	44	52	60	68	76	84	92
8	E E P R O M I n f o .																							
16	- - - - -																							
24	D I S P L A Y : \$ \$ \$ \$ \$ \$ \$ \$ \$																							
32																								
40	S Y S T E M : \$ \$ \$ \$ \$ \$ \$ \$ \$																							
48																								

\$\$\$\$\$\$\$\$:Error information  
When ROM collection is not connected:  
NO\_EEPROM  
ROM collection data error:ROM\_ERROR

(2) If information is successfully acquired from EEPROM

0	8	16	24	32	40	48	56	64	72	80	88	96	04	12	20	28	36	44	52	60	68	76	84	92
8	E E P R O M I n f o .																							
16	- - - - -																							
24	D I S P L A Y : # # # # - ! ! ! !																							
32																								
40	S Y S T E M : # # # # - ! ! ! !																							
48																								

####:EEPROM collection version information  
!!!!:CH use information  
(1: Used, 0: Not used. Corresponding to: CH1, CH2, CH3 and CH4 from left)

- If nothing appears on the screen:  
There might be a problem in communication or abnormality in the display microcomputer.
- If an obviously weird numeral appears as the version:  
There might be a problem in communication.
- If the number of CHs used is not properly displayed despite the version displayed:  
There might be defective connection with EEPROM.

F

All lights OFF

0	8	16	24	32	40	48	56	64	72	80	88	96	04	12	20	28	36	44	52	60	68	76	84	92	
8																									
16																									
24																									
32																									
40																									
48																									

- If noise appears on the screen:  
There might be abnormality in the display microcomputer or a problem, for instance, in connection between the display microcomputer and the OEL driver.

Confirmation of image ROM connection

0	8	16	24	32	40	48	56	64	72	80	88	96	04	12	20	28	36	44	52	60	68	76	84	92	
8	B	u	s		C	o	n	n	e	c	t		T	e	s	t									
16	-	-	-	-	-	-	-	-	-	-	-	-	-	-	-	-	-	-	-	-	-	-	-	-	
24	D	A	T	A		B	u	s		:		#	#												
32	A	D	R	S		B	u	s		:		#	#												
48																									

##:OK or NG

- If nothing appears on the screen:  
There might be a problem in communication or abnormality in the display microcomputer.
- If NG appears somewhere:  
There might be defective connection between the display microcomputer and image ROM.  
For instance, NG appearing with respect to the data bus does not necessarily mean data bus connection is definitely defective.  
Where the address bus is the reason for NG appearing, an error could still occur when checking the data bus.

Display of media microcomputer information

0	8	16	24	32	40	48	56	64	72	80	88	96	04	12	20	28	36	44	52	60	68	76	84	92	
8	M	E	D	I	A		I	n	f	o	.														
16	-	-	-	-	-	-	-	-	-	-	-	-	-	-	-	-	-	-	-	-	-	-	-	-	
24	P	D			*	*	*	*	*	*															
32	U	N	I	T		○	?	?	?	?															
40	V	e	r		*	*	.	*	*																
48																									

Description:  
UNIT  
○:  
Caution: The display is blank because nothing is sent from the media microcomputer.  
????:Media microcomputer unit number information

- If nothing appears on the screen:  
There might be a problem in communication to the display microcomputer, or abnormality in the display microcomputer itself.
- If an obviously weird numeral appears on the media microcomputer version:  
There might be a problem in communication between the system microcomputer and display microcomputer, or between the system and media microcomputer.

Display of Manufacture\_ID information (UC only)

0	8	16	24	32	40	48	56	64	72	80	88	96	04	12	20	28	36	44	52	60	68	76	84	92	
8	M	a	n	u	f	a	c	t	u	r	e		I	D											
16	-	-	-	-	-	-	-	-	-	-	-	-	-	-	-	-	-	-	-	-	-	-	-	-	
24	0	x	C	0	2	8	2	0	E	D															
32																									
40																									
48																									

## 6.2 CD TEST MODE

### Flow Chart

To enter the test mode: [PHONE] + [BAND] -> BUP + ACC ON (UC, EW5)  
 [COLOR] + [BAND] -> BUP + ACC ON (ES)

Operate with a Remote Control with 1 - 6 keys for a CD Receiver in the test mode.

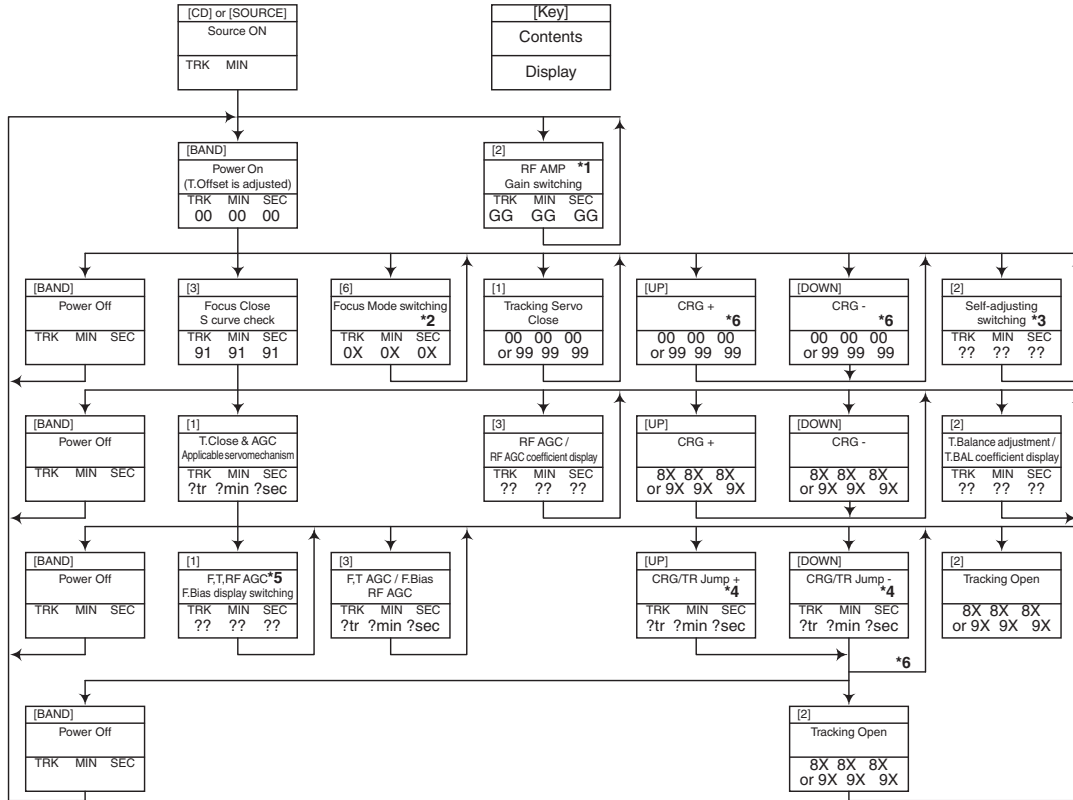

\*1) TYP -- + 6 dB -- + 12 dB  
 TRK MIN SEC TRK<sub>06</sub>MIN<sub>06</sub>SEC<sub>06</sub> TRK<sub>12</sub>MIN<sub>12</sub>SEC<sub>12</sub>

\*2) Focus Close -- S. Curve -- F EQ measurement setting  
 TRK<sub>00</sub>MIN<sub>00</sub>SEC<sub>00</sub> TRK<sub>01</sub>MIN<sub>01</sub>SEC<sub>01</sub> TRK<sub>02</sub>MIN<sub>02</sub>SEC<sub>02</sub>  
 (TRK<sub>99</sub>MIN<sub>99</sub>SEC<sub>99</sub>)

\*3) F.Offset Display -- RF.Offset -- T.Offset Display -- Switch to the order of the original display

\*4) 100TR Jump

\*5) TRK/MIN/SEC -- F.AGC -- T.AGC Gain -- F.Bias -- RF AGC

\*6) CRG motor voltage = 2 [V]

[Key]	Operation
[BAND]	Power On/Off
[UP]	CRG + / TR Jump + (Direction of the external surface)
[DOWN]	CRG - / TR Jump - (Direction of the internal surface)
[1]	T. CLS & AGC & Applicable servomechanism / AGC,AGC display setting
[2]	RF Gain switching / Offset adjustment display / T.Balance adjustment / T. Open
[3]	F. Close,S. Curve / Rough Servo and RF AGC / F,T,RF AGC
[6]	F. Mode switching / Tracking Close

- After the [EJECT] key is pressed keys other than the [EJECT] key should not be pressed, until disc ejection is complete.
- When the key [UP] or [DOWN] is pressed during the Focus Search, the power supply should be immediately turned off (otherwise the lens sticks to Wall, causing the actuator to be damaged).
- In the case of 100TR Jump, the mechanism shall be set to the Tracking Close mode when the key is released.
- When the power is turned on/off the gain of the RFAMP is reset to 0 dB. At the same time all the self-adjusting values shall return to the default setting.
- Do not do Tracking Servo Close before doing Focus Servo Close. (Because the overcurrent flows)

# 7. DISASSEMBLY

While the photograph shown is slightly different from this model in shape, the disassembly procedure is the same.

## ● Removing the Panel Assy (Fig.1)

- 1** Remove the two screws.
- 2** Release the two latches and then remove the Panel Assy.

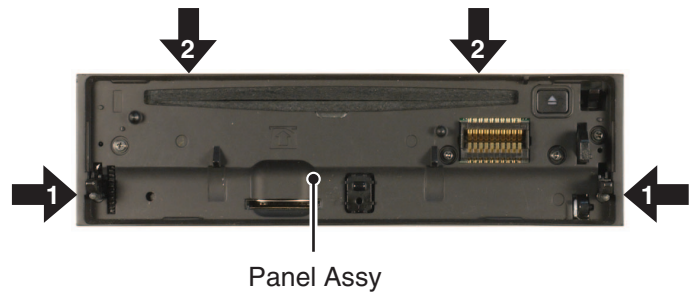

Fig.1

## ● Removing the CD Mechanism Module (Fig.2, 3, 4)

- 1** Remove the screw.
- 2** Remove the two screws.

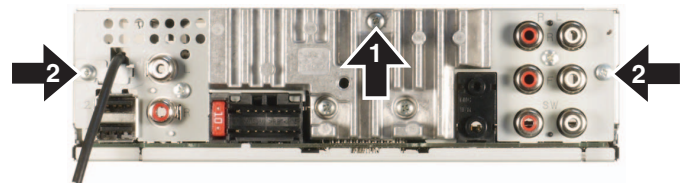

Fig.2

The CD Mechanism Module side is made a bottom.

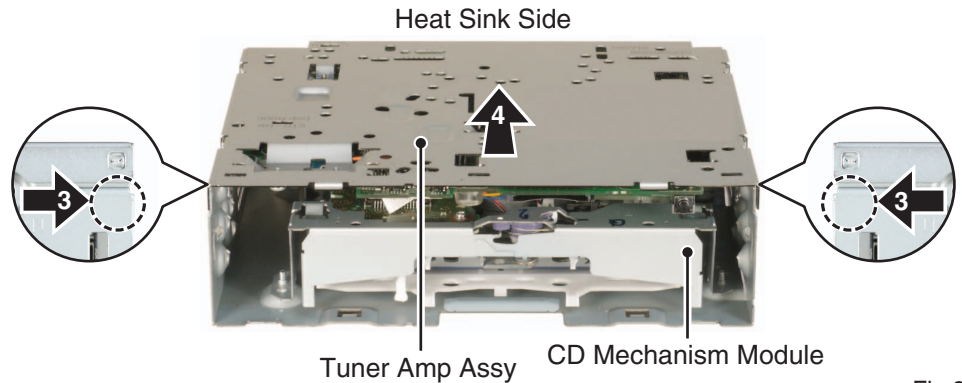

Fig.3

- 3** Push the area and remove the two hooks.
- 4** Slide the Tuner Amp Assy in the direction of the arrow.

Lift off the Tuner Amp Assy from the Front Side.

- 5** Disconnect the FFC and then remove the CD Mechanism Module.

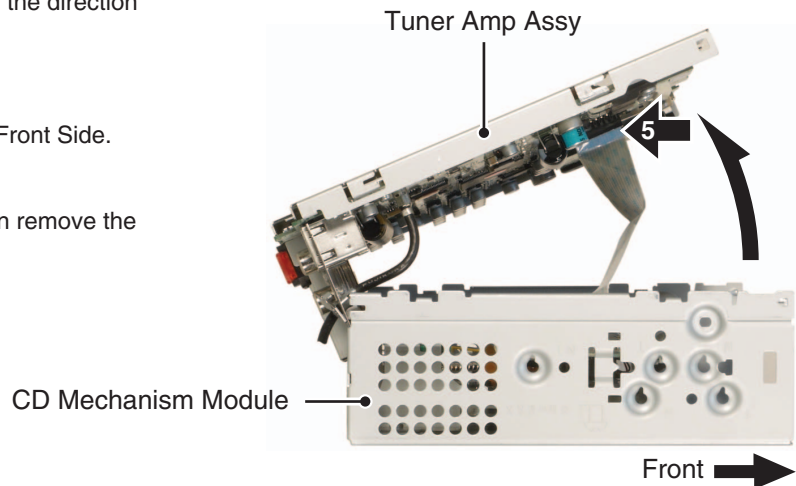

Fig.4

● Removing the Tuner Amp Unit (Fig.5)

1 Remove the two screws.

2 Remove the two screws.

3 Straighten the tabs at three locations indicated and then remove the Tuner Amp Unit.

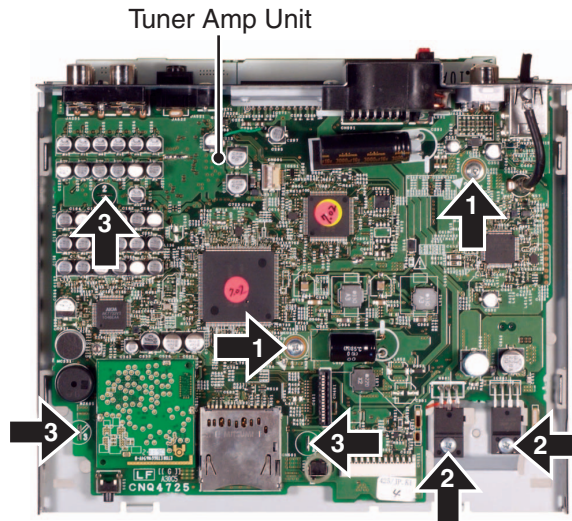
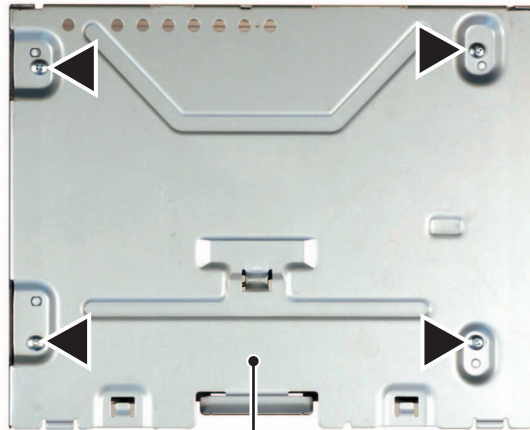

Fig.5

● Attention of removing (Fig.6)

Don't remove this screws excluding the dismantlement of the CD Mechanism Module.



CD Mechanism Module

Fig.6

## ● How to carry the mecha unit

1. Hold the designated points (shown with dashed lines) of the upper chassis and the front/rear bracket.
2. Be careful not to hold the solid line portions or the CRG mecha part or insert foreign substances, to prevent distortion.
3. When holding the sides of the upper chassis, do not apply excessive force to prevent distortion. (Approx. 8N or less)

Handling OK

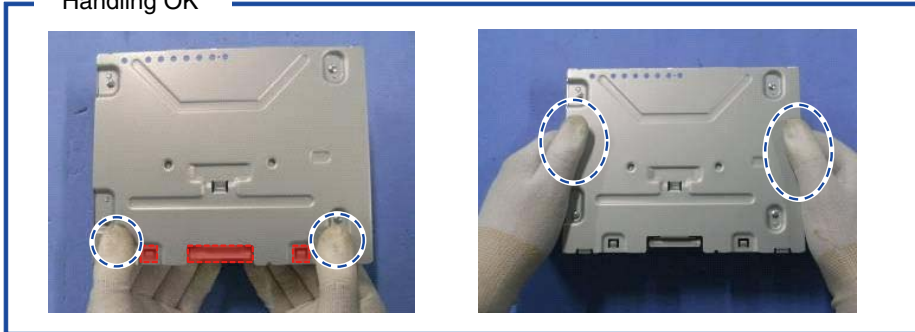

Handling NG

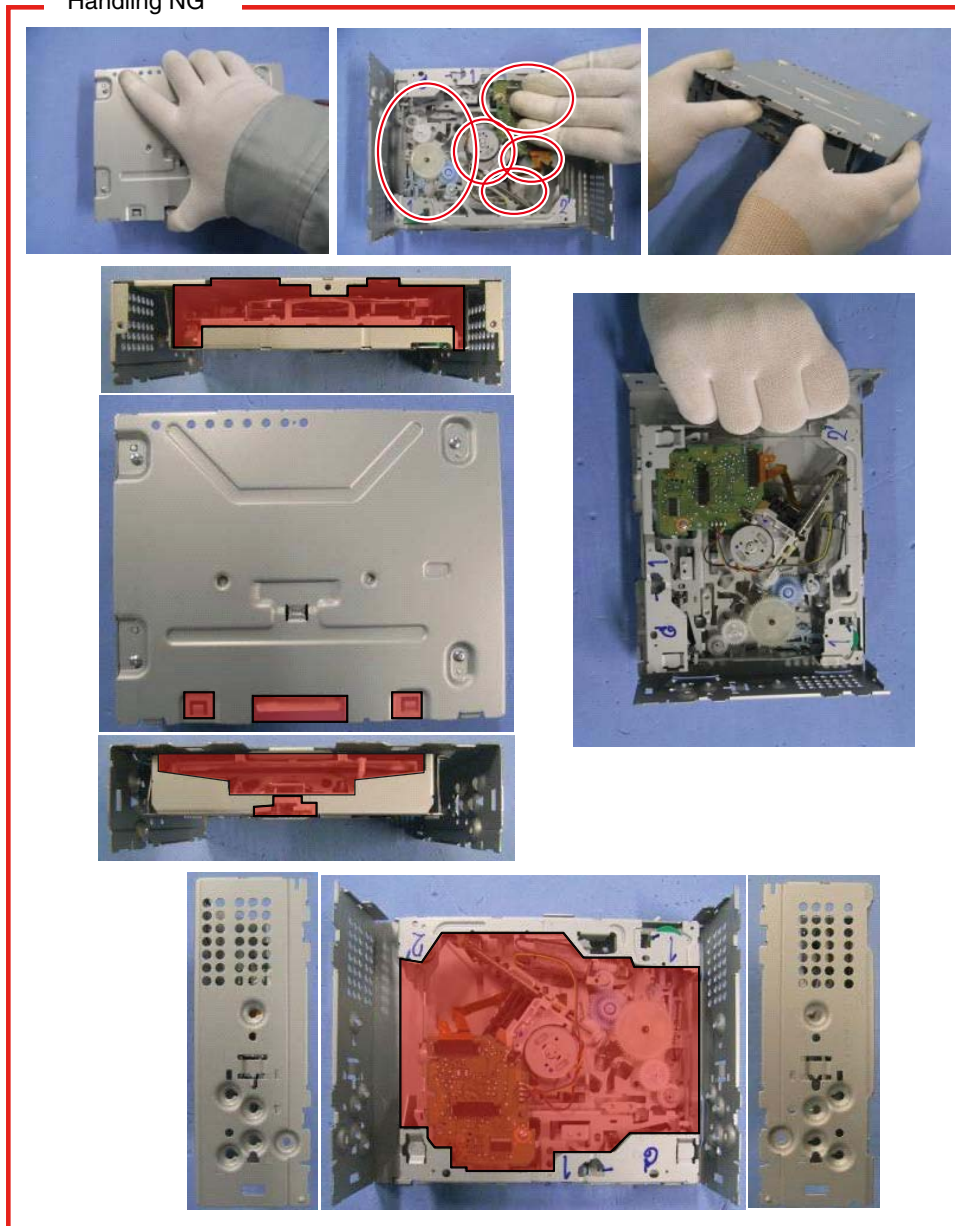

### ● How to remove the PU unit

A

1. Create an empty-clamp state according to "How to create empty clamp state (motor drive)".
2. Hook the feeding screw biasing spring to a tentative hooking portion (Fig 2b). Be careful not to get injured by the spring edge.
3. Hold the PU at the position A as shown in Fig 1. Slide the PU as far as possible toward the holder in the feeding screw so that a joint on the outer end of the feeding screw is loosened.
4. As shown in Fig 3, move the rear end of the feeding screw laterally and then upward, to remove it from the outer holder.
5. Lift the PU unit to disengage it from Part B of the chassis (Fig 4), and remove the PU unit.

(Cautions) When re-installing the PU, be sure to first nip the chassis and the PU unit (Fig 4) at the position B.  
 Also, make sure to fully hook the feeding screw biasing spring (Fig 2a).  
 Please follow the service manual for adjustment of the PU unit after the re-installation.

B

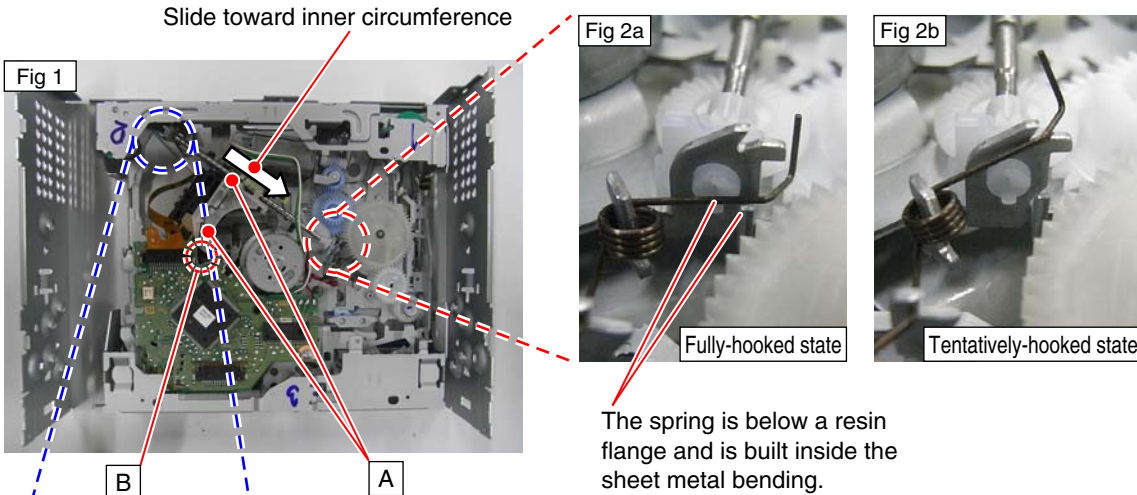

C

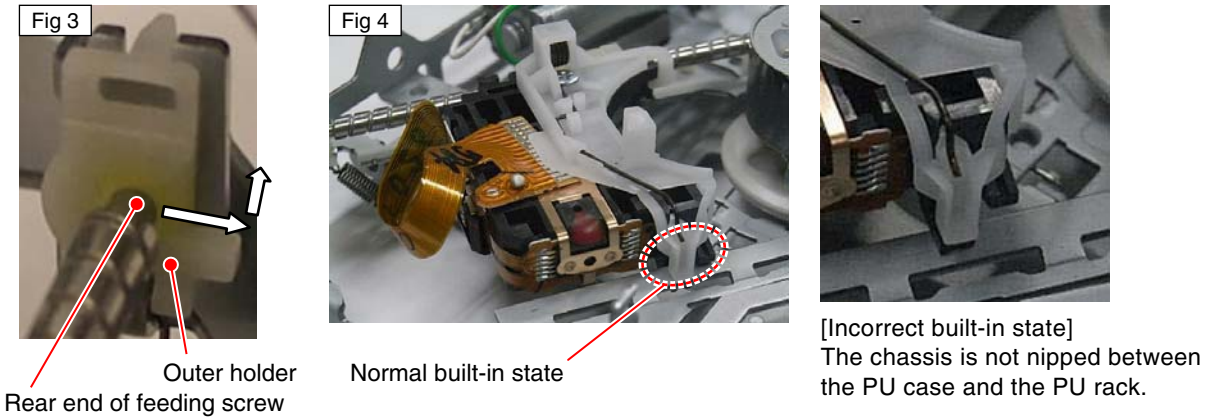

D

E

F



## 8. EACH SETTING AND ADJUSTMENT

### 8.1 CD ADJUSTMENT

#### 1) Cautions on adjustments

- In this product the single voltage (3.3 V) is used for the regulator. The reference voltage is the REFO1 (1.65 V) instead of the GND.

If you should mistakenly short the REFO1 with the GND during adjustment, accurate voltage will not be obtained, and the servo's misoperation will apply excessive shock to the pickup. To avoid such problems:

a. Do not mix up the REFO1 with the GND when connecting the (-) probe of measuring instruments. Especially on an oscilloscope, avoid connecting the (-) probe for CH1 to the GND.

b. In many cases, measuring instruments have the same potential as that for the (-) probe. Be sure to set the measuring instruments to the floating state.

c. If you have mistakenly connected the REFO1 to the GND, turn off the regulator or the power immediately.

- Before mounting and removing filters or leads for adjustment, be sure to turn off the regulator.

- For stable circuit operation, keep the mechanism operating for about one minute or more after the regulator is turned on.

- In the test mode, any software protections will not work. Avoid applying any mechanical or electrical shock to the mechanism during adjustment.

- The RFAGC and RFO signals with a wide frequency range are easy to oscillate. When observing the signals, insert a resistor of 1k ohms in series.

- The load and eject operation is not guaranteed with the mechanism upside down. If the mechanism is blocked due to mistaken eject operation, reset the product or turn off and on the ACC to restore it.

#### 2) Test mode

This mode is used to adjust the CD mechanism module.

- To enter the test mode.

[PHONE] + [BAND] -> BUP + ACC ON (UC, EW5)

[COLOR] + [BAND] -> BUP + ACC ON (ES)

- To exit from the test mode.

Turn off the ACC and back up.

#### Notes:

a. During ejection, do not press any other keys than the EJECT key until the loaded disc is ejected.

b. If you have pressed the (UP) key or (DOWN) key during focus search, turn off the power immediately to protect the actuator from damage caused by the lens stuck.

c. For the TR jump modes except 100TR, the track jump operation will continue even if the key is released.

d. For the CRG move and 100TR jump modes, the tracking loop will be closed at the same time when the key is released.

e. When the power is turned off and on, the jump mode is reset to the single TR (91), the RF amp gain is set to 0 dB, and the auto-adjustment values are reset to the default settings.

## 8.2 CHECKING THE GRATING AFTER CHANGING THE PICKUP UNIT



### • Note :

The grating angle of the PU unit cannot be adjusted after the PU unit is changed. The PU unit in the CD mechanism module is adjusted on the production line to match the CD mechanism module and is thus the best adjusted PU unit for the CD mechanism module. Changing the PU unit is thus best considered as a last resort. However, if the PU unit must be changed, the grating should be checked using the procedure below.

### • Purpose :

To check that the grating is within an acceptable range when the PU unit is changed.

### • Symptoms of Mal-adjustment :

If the grating is off by a large amount symptoms such as being unable to close tracking, being unable to perform track search operations, or taking a long time for track searching.

### • Method :

- Measuring Equipment
  - Oscilloscope, Two L.P.F.
- Measuring Points
  - E, F, REFO1
- Disc
  - TCD-782
- Mode
  - TEST MODE

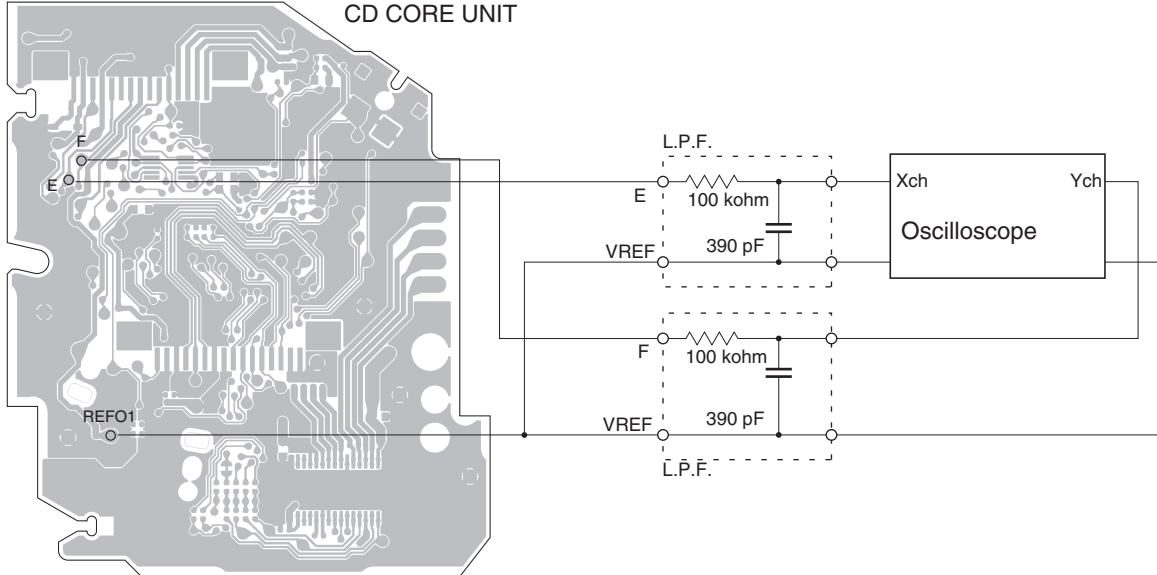

### • Checking Procedure

1. In test mode, load the disc and switch the 3 V regulator on.
2. Using the UP and DOWN buttons, move the PU unit to the innermost track.
3. Press key 3 to close focus, the display should read "91". Press key 2 to implement the tracking balance adjustment the display should now read "81". Press key 3. The display will change, returning to "81" on the fourth press.
4. As shown in the diagram above, monitor the LPF outputs using the oscilloscope and check that the phase difference is within  $75^\circ$ . Refer to the photographs supplied to determine the phase angle.
5. If the phase difference is determined to be greater than  $75^\circ$  try changing the PU unit to see if there is any improvement. If, after trying this a number of times, the grating angle does not become less than  $75^\circ$  then the mechanism should be judged to be at fault.

### • Note

Because of eccentricity in the disc and a slight misalignment of the clamping center the grating waveform may be seen to "wobble" ( the phase difference changes as the disc rotates). The angle specified above indicates the average angle.

### • Hint

Reloading the disc changes the clamp position and may decrease the "wobble".

### Grating waveform

Ech -> Xch 20 mV/div, AC

Fch -> Ych 20 mV/div, AC

0 degrees

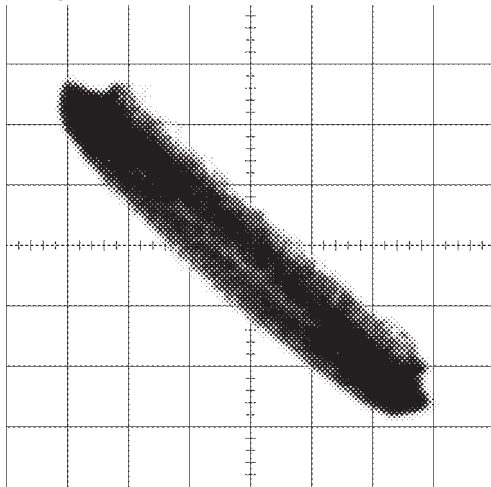

30 degrees

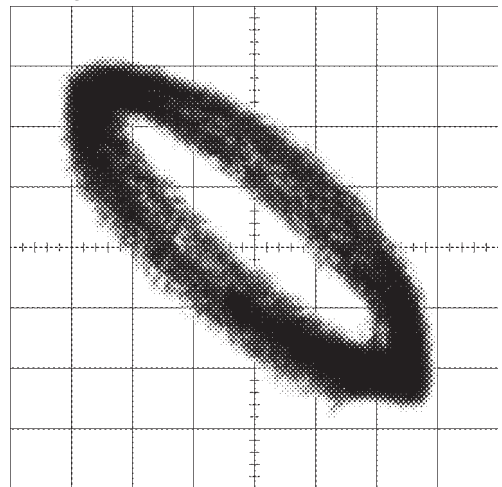

45 degrees

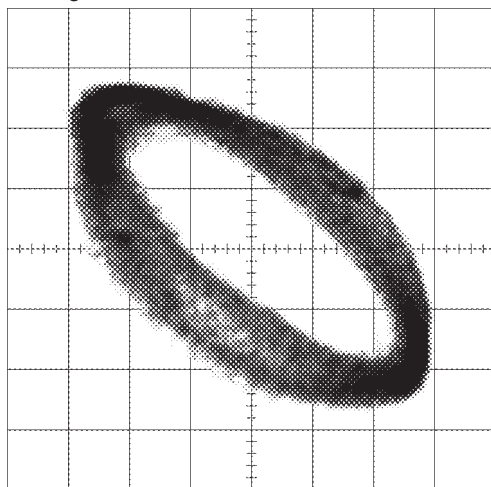

60 degrees

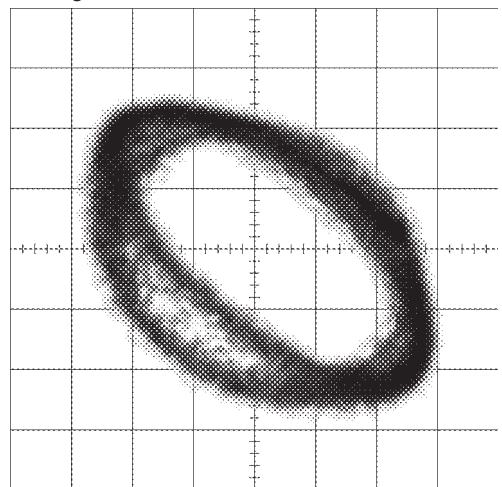

75 degrees

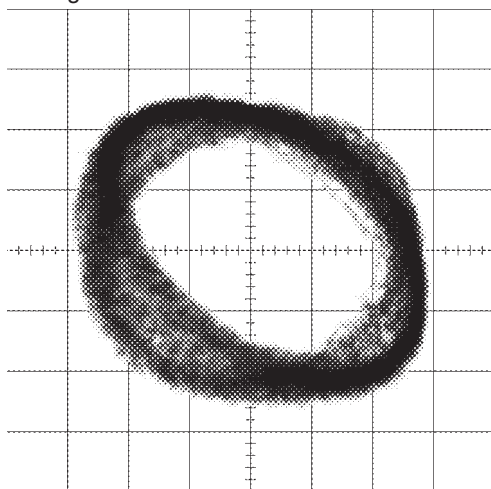

90 degrees

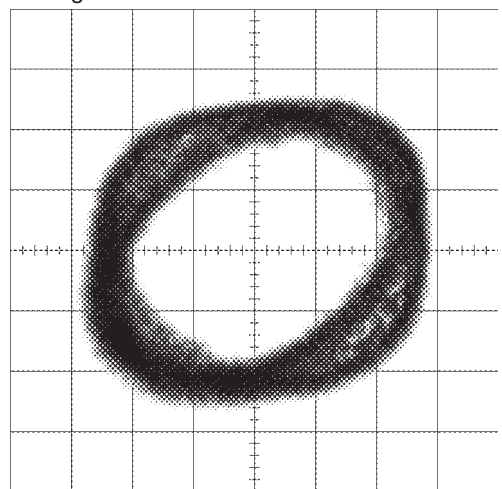

A

B

C

D

E

F

### 8.3 PCL OUTPUT CONFIRMATION

A



#### ● PCL Output

In the normal operation mode (with the detachable panel installed, the ACC switched ON, the standby mode cancelled), shift the TEST\_IN IC601 (Pin 61) terminal(TP : TESTIN1) to H.

The clock signal is output from the PCL terminal IC601 (Pin 37)(TP : PCL).

The frequency of the clock signal is 625.0 kHz that is one 32th of the fundamental frequency (20 MHz).

If the clock signal out of the range, the X'tal (X601) should be replaced with new one.

B

C

D

E

F

A

B



C

D

E

F

# 9. EXPLODED VIEWS AND PARTS LIST

- NOTES :
- Parts marked by "\*" are generally unavailable because they are not in our Master Spare Parts List.
  - The  mark found on some component parts indicates the importance of the safety factor of the part. Therefore, when replacing, be sure to use parts of identical designation.
  - Screw adjacent to  mark on the product are used for disassembly.
  - For the applying amount of lubricants or glue, follow the instructions in this manual.  
(In the case of no amount instructions, apply as you think it appropriate.)

## 9.1 PACKING

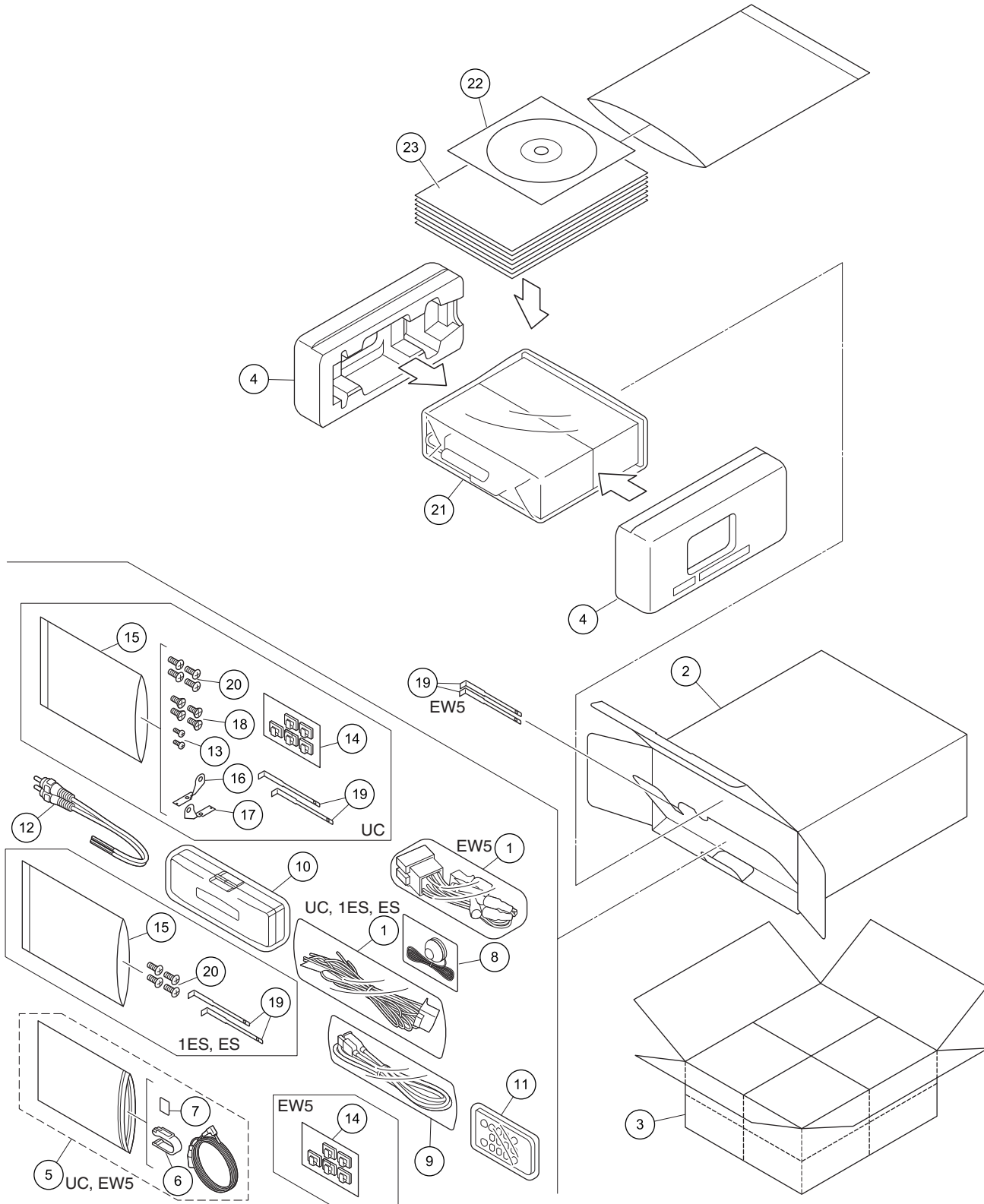

**(1) PACKING SECTION PARTS LIST**

<u>Mark No.</u>	<u>Description</u>	<u>Part No.</u>	<u>Mark No.</u>	<u>Description</u>	<u>Part No.</u>
1	Cord Assy	See Contrast table (2)	16	Holder	See Contrast table (2)
2	Unit Box	See Contrast table (2)	17	Holder	See Contrast table (2)
3	Contain Box	See Contrast table (2)	18	Screw	See Contrast table (2)
4	Protector	CHP4356	19	Handle	QNC3021
5	Microphone Assy	See Contrast table (2)	20	Screw	See Contrast table (2)
6	Holder	See Contrast table (2)	21	Cover	See Contrast table (2)
7	Cushion	See Contrast table (2)	22	IM CD-ROM	See Contrast table (2)
8	Microphone Assy	CPM1086	23-1	Quick Start Guide	See Contrast table (2)
9	USB Extended Cable	QDP3021	23-2	Quick Start Guide	See Contrast table (2)
10	Case Assy	QXA3129	23-3	Installation Manual	See Contrast table (2)
11	Card Remote Control Unit	See Contrast table (2)	*	23-4 Caution Card	CRP1441
12	Cord Assy	YDE5010	*	23-5 Caution Card	See Contrast table (2)
13	Screw	See Contrast table (2)	*	23-6 Caution Card	See Contrast table (2)
14	Cord Clamper Assy	See Contrast table (2)	*	23-7 Warranty Card	See Contrast table (2)
15	Polyethylene Bag	See Contrast table (2)			

**(2) CONTRAST TABLE**

DEH-80PRS/XNUC, DEH-80PRS/XNEW5 and DEH-80PRS/XNES are constructed the same except for the following:

<u>Mark</u>	<u>No.</u>	<u>Description</u>	<u>DEH-80PRS/XNUC</u>	<u>DEH-80PRS/XNEW5</u>	<u>DEH-80PRS/XNES</u>
	1	Cord Assy	CDP1484	QDP3024	CDP1484
	2	Unit Box	CHG7753	CHG7752	CHG7755
	3	Contain Box	CHL7753	CHL7752	CHL7755
	5	Microphone Assy	CPM1083	CPM1083	Not used
	6	Holder	CZN7192	CZN7192	Not used
	7	Cushion	CZN7193	CZN7193	Not used
	11	Card Remote Control Unit	QXE1044	QXE1044	QXE1047
	13	Screw	BPZ20P060FTC	Not used	Not used
	14	Cord Clamper Assy	CEA4636	CEA4636	Not used
	15	Polyethylene Bag	CEG1160	Not used	CEG1160
	16	Holder	CND1249	Not used	Not used
	17	Holder	CND1250	Not used	Not used
	18	Screw	CRZ50P090FTC	Not used	Not used
	20	Screw	TRZ50P080FTC	Not used	TRZ50P080FTC
	21	Cover	CEG1419	CEG1418	CEG1418
	22	IM CD-ROM	CPJ1371	CPJ1370	CPJ1372
	23-1	Quick Start Guide	CRD4614	CRD4612	CRD4615
	23-2	Quick Start Guide	Not used	CRD4613	CRD4616
	23-3	Installation Manual	CRD4618	CRD4617	CRD4619
*	23-5	Caution Card	CRP1457	CRP1451	CRP1458
*	23-6	Caution Card	Not used	CRP1452	Not used
*	23-7	Warranty Card	QRY3001	CRY1376	Not used

**Owner's Manual, Installation Manual**

Part No.	Language
CRD4612	English, French, Italian, Spanish(Espanol)
CRD4613	German, Dutch, Russian
CRD4614	English, French, Spanish(Espanol)
CRD4615	English, Spanish(Espanol), Portuguese(B)
CRD4616	Traditional Chinese, Arabic
CRD4617	English, French, Italian, Spanish(Espanol), German, Dutch, Russian
CRD4618	English, French, Spanish(Espanol)
CRD4619	English, Spanish(Espanol), Portuguese(B), Traditional Chinese, Arabic

**CONTENTS OF CD-ROM (Operation Manual), CPJ1370, CPJ1371 AND CPJ1372**

Part No.	Language
* CRB3824	English
* CRB3825	French
* CRB3826	Italian
* CRB3827	Spanish(Espanol)
* CRB3828	German
* CRB3829	Dutch
* CRB3830	Russian
* CRB3831	English
* CRB3832	French
* CRB3833	Spanish(Espanol)
* CRB3834	English
* CRB3835	Spanish(Espanol)
* CRB3836	Portuguese(B)
* CRB3837	Traditional Chinese
* CRB3838	Arabic

**All operation manuals are supplied in PDF files by the CD-ROM.**

**Regarding the availability of paper manual, contact Pioneer Service representative in your region.**



■

5

■

6

■

7

■

8

■

A

■

B

■

C

■

D

■

E

■

F

■

5

■

6

DEH-80PRS/XNUC

■

7

■

8

■

# 9.2 EXTERIOR

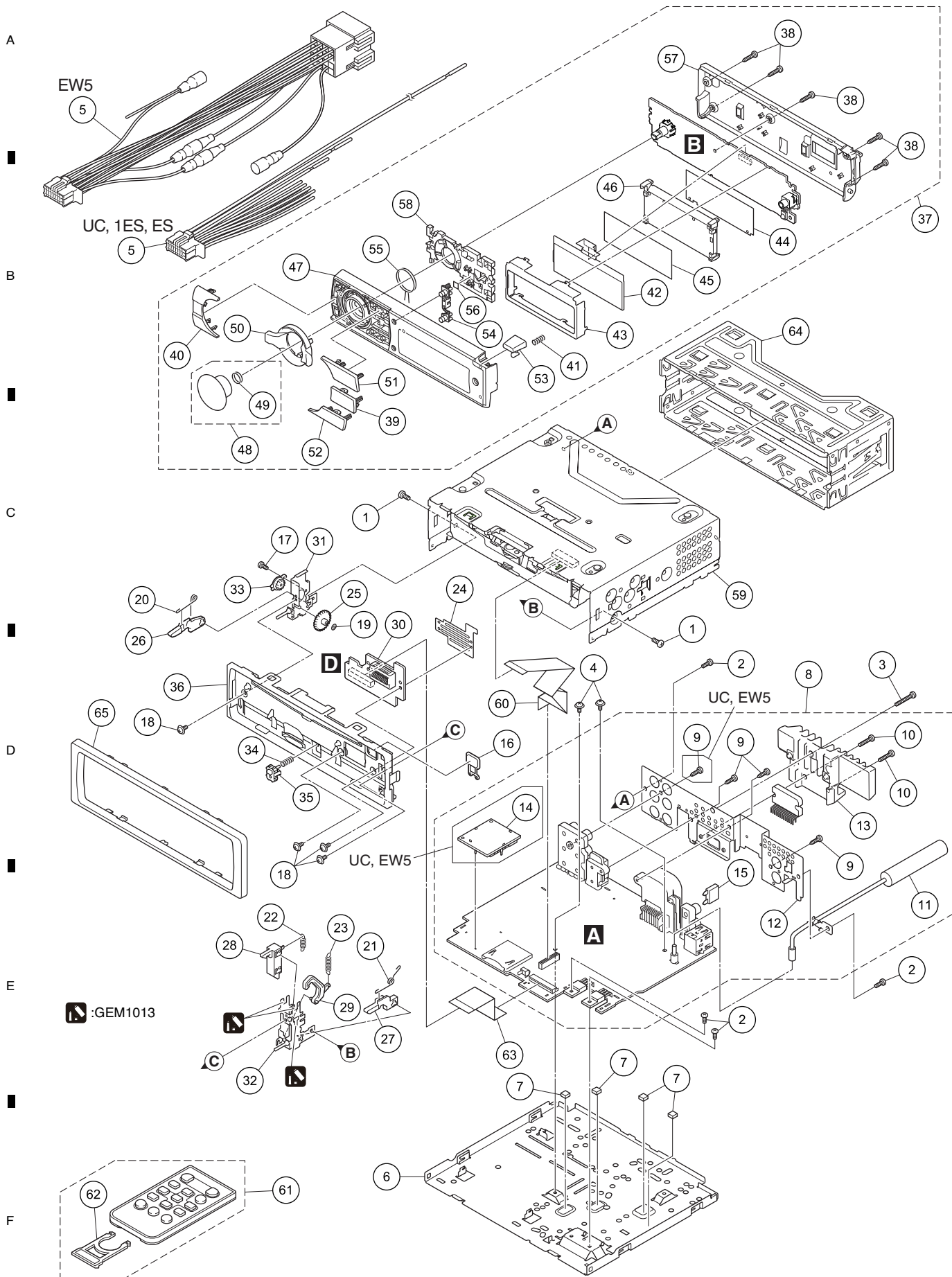

DEH-80PRS/XNUC

**(1) EXTERIOR SECTION PARTS LIST**

<u>Mark No.</u>	<u>Description</u>	<u>Part No.</u>	<u>Mark No.</u>	<u>Description</u>	<u>Part No.</u>
1	Screw	BMZ30P040FTC	34	Spring	YBH5013
2	Screw	BSZ26P060FTC	35	Button	YAC5395
3	Screw	BSZ26P120FTC			
4	Screw (M2.6 x 5)	CBA2274	36	Panel	YNS5658
5	Cord Assy	See Contrast table (2)	37	Grille Assy	See Contrast table (2)
			38	Screw	BPZ20P100FTC
6	Case	CNB3797	39	Button (DISP OFF)	CAI3746
7	Sheet	CNN3987	40	Button	See Contrast table (2)
8	Tuner Amp Unit	See Contrast table (2)			
9	Screw	BPZ26P080FTC	41	Spring	CBH2210
10	Screw (M2.6 x 12)	CBA2302	42	STN LCD	YAW5113
			43	Holder	YNC5097
11	Antenna Cable	CDH1399	44	Sheet	YNM5174
12	Holder	See Contrast table (2)	45	Sheet	YNM5199
13	Heat Sink	CNR2120			
14	BT Module	See Contrast table (2)	46	Plate Unit	YXA5834
⚠ 15	Fuse (10A)	YEK5001	47	Grille Unit	See Contrast table (2)
			48	Knob Assy	CXE5188
16	Button (EJECT)	CAC7752	49	Spring	YBL5010
17	Screw (M2 x 3)	CBA1677	50	Lever	YAA5084
18	Screw (M2 x 4.5)	CBA1925			
19	Washer	CBF1038	51	Button (DISP)	YAC5443
20	Spring	CBH2650	52	Button (SRC)	YAC5445
			53	Button (DETACH)	YAC5447
21	Spring	CBH2651	54	Button (UP/DOWN)	YAC5448
22	Spring	CBH2652	55	Spring	YBH5016
23	Spring	CBH2653			
24	Holder	CND1254	56	Sheet	YNM5195
25	Gear	CNV5997	57	Cover	YNS5657
			58	Lighting Conductor	YNV5226
26	Arm	CNV7400	59	CD Mechanism Module (S11.6)	CXK5804
27	Arm	CNV7401	60	FFC	QDE3021
28	Arm	CNV7402			
29	Arm	CNV7403	61	Card Remote Control Unit	See Contrast table (2)
30	Panel Unit	CWN6306	62	Cover	CNS7068
			63	FFC	YDE5097
31	Holder Unit	CXB9501	64	Holder	QNC3020
32	Holder Unit	CXB9502	65	Panel	YNS5687
33	Damper Unit	CXB9503			

**(2) CONTRAST TABLE**

DEH-80PRS/XNUC, DEH-80PRS/XNEW5 and DEH-80PRS/XNES are constructed the same except for the following:

Mark	No.	Description	DEH-80PRS/XNUC	DEH-80PRS/XNEW5	DEH-80PRS/XNES
	5	Cord Assy	CDP1484	QDP3024	CDP1484
	8	Tuner Amp Unit	CWN6303	CWN6302	CWN6304
	12	Holder	CND6279	CND6279	CND6281
	14	BT Module	CWX4188	CWX4188	Not used
	37	Grille Assy	CXE4880	CXE4879	CXE4881
	40	Button	CAI3751 (PHONE)	CAI3751 (PHONE)	CAI3752 (COLOR)
	47	Grille Unit	CXE4898	CXE4898	CXE4899
	61	Card Remote Control Unit	QXE1044	QXE1044	QXE1047

# 9.3 CD MECHANISM MODULE

A

B

C

D

E

F

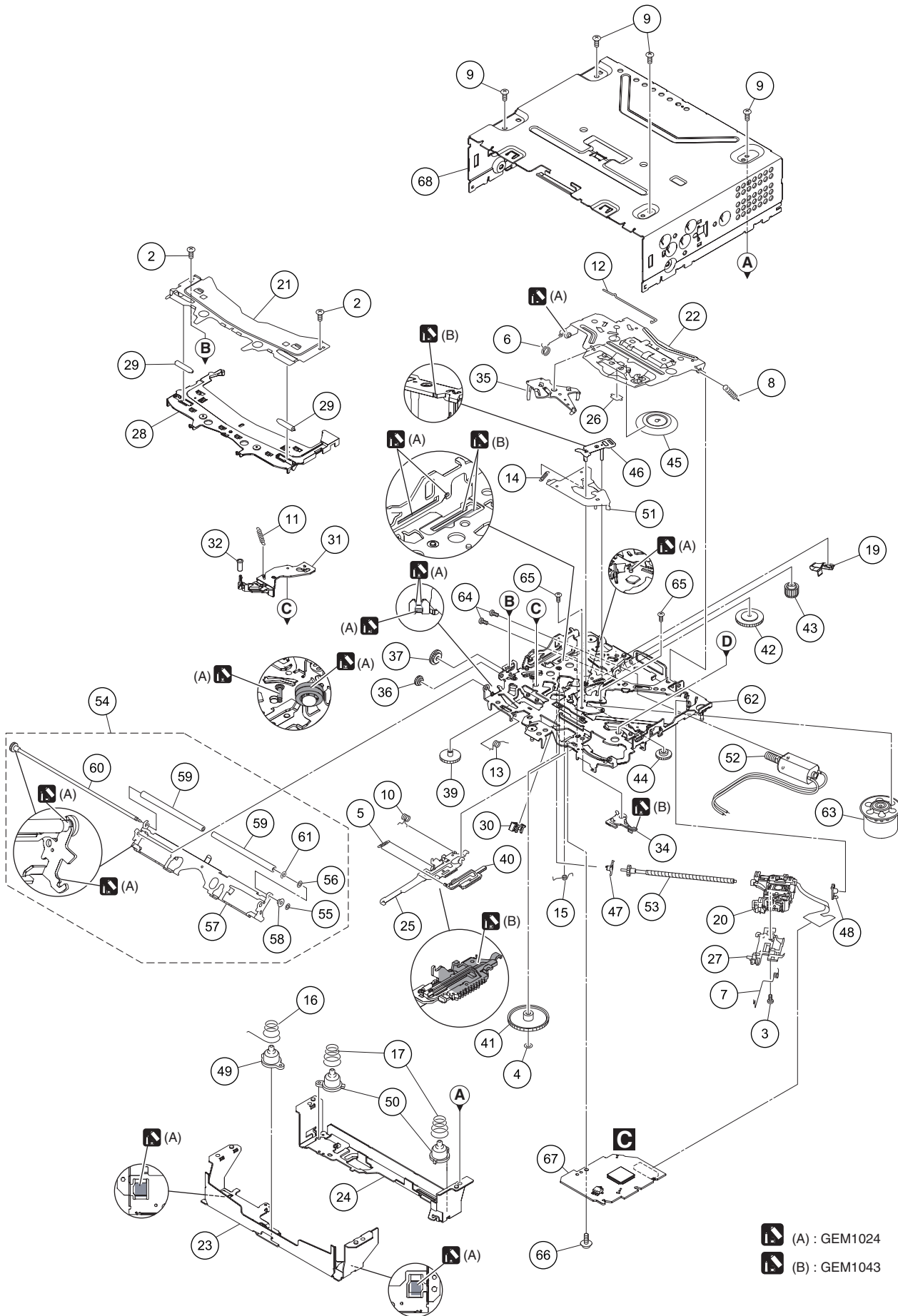

(A) : GEM1024  
 (B) : GEM1043

## CD MECHANISM MODULE SECTION PARTS LIST

<u>Mark No.</u>	<u>Description</u>	<u>Part No.</u>	<u>Mark No.</u>	<u>Description</u>	<u>Part No.</u>
1	.....		50	Damper	CNW1198
2	Screw	BSZ20P040FTC	51	Arm	CNW1726
3	Screw(M2 x 4)	CBA1835	52	Motor Unit(M2)(LOAD/CRG)	CXC4026
4	Washer	CBF1038	53	Screw Unit	CXC8894
5	Spring	CBH3010	54	Arm Assy	CXE5027
6	Spring	CBH2855	55	Washer	CBF1037
7	Spring	CBH2856	56	Washer	CBF1038
8	Spring	CBH2860	57	Arm	CND6242
9	Screw	BSZ26P060FTC	58	Collar	CNW2444
10	Spring	CBH3011	59	Roller	CNW1196
11	Coil Spring	CBH3095	60	Gear Unit	CXC8893
12	Spring	CBH3014	61	Washer	YE15FTC
13	Spring	CBH3015	62	Chassis Unit	CXE4528
14	Spring	CBH3016	63	Motor Unit(M1)(SPDL)	CXE2273
15	Spring	CBH3017	64	Screw	JFZ20P025FTC
16	Spring	CBH3086	65	Screw	JGZ17P022FTC
17	Spring	CBH3019	66	Screw	EBA1028
18	.....		67	CD Core Unit (S11.6STD)	CWX4023
19	Leaf Spring	CBL1824	68	Chassis	CNA3181
20	Pickup Unit(P10.6)(Service)	CXX3556			
21	Bracket	CND4553			
22	Arm	CND4555			
23	Bracket	CND6127			
24	Bracket	CND5710			
25	Lever	CND5398			
26	Sheet	CNN3678			
27	Rack	CNV8342			
28	Guide	CNW2240			
29	Roller	CNW1172			
30	Holder	CNW1195			
31	Arm	CNW2241			
32	Roller	CNW1175			
33	.....				
34	Arm	CNW1177			
35	Arm	CNW1178			
36	Gear	CNW1180			
37	Gear	CNW1181			
38	.....				
39	Gear	CNW1183			
40	Rack	CNW1184			
41	Gear	CNW1185			
42	Gear	CNW1186			
43	Gear	CNW1187			
44	Gear	CNW2287			
45	Clamper	CNW1190			
46	Arm	CNW1192			
47	Holder	CNW1193			
48	Holder	CNW1194			
49	Damper	CNW1197			

# 10. SCHEMATIC DIAGRAM

## 10.1 TUNER AMP UNIT (SYSTEM BLOCK) (GUIDE PAGE)

Note: When ordering service parts, be sure to refer to "EXPLODED VIEWS AND PARTS LIST" or "ELECTRICAL PARTS LIST".

A-a 1/4

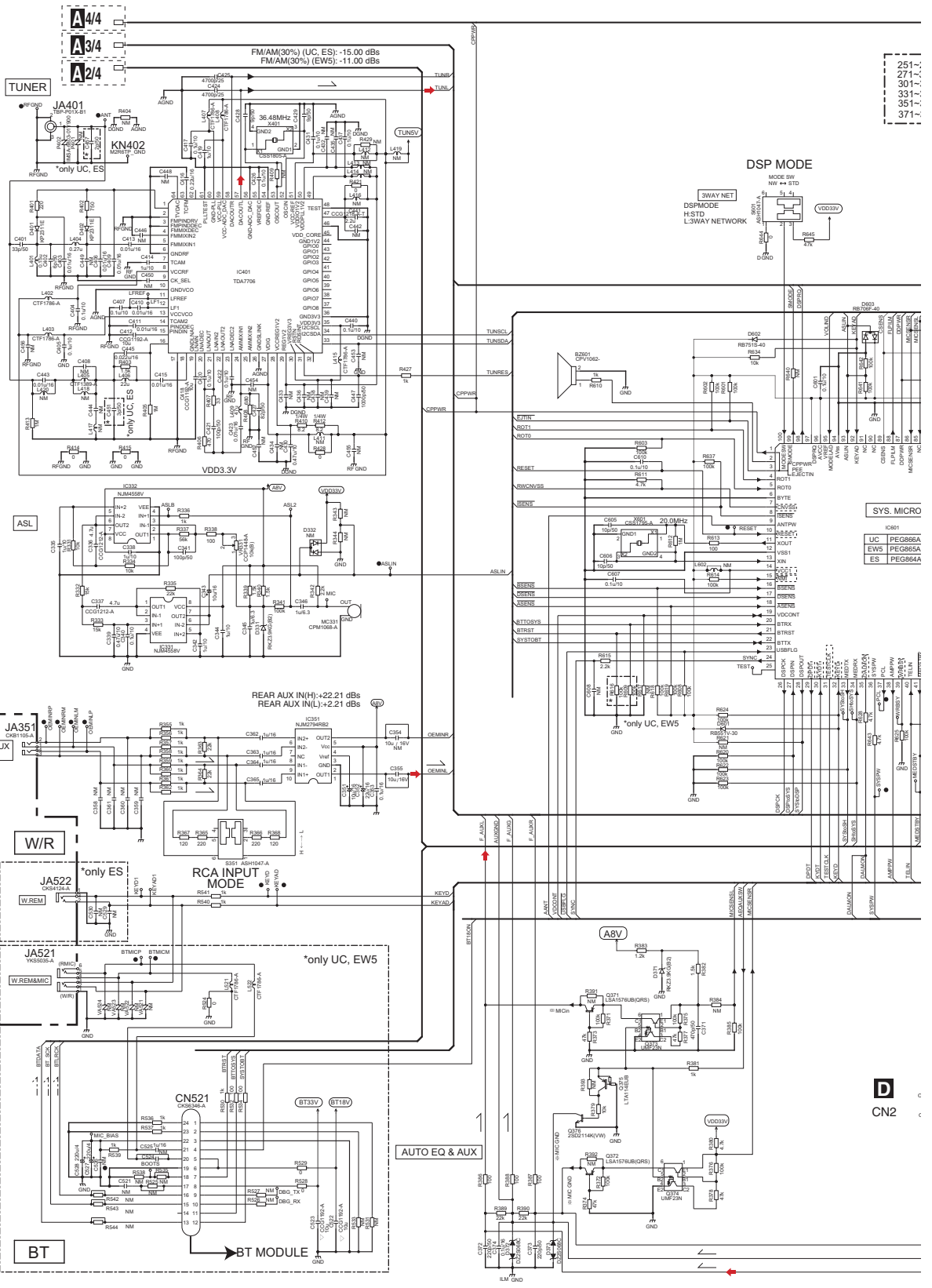
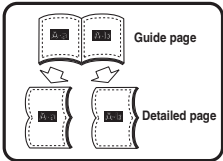
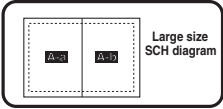

- 251
- 271
- 301
- 331
- 351
- 371

- IC901
- UC PEG686A
- ES PEG685A
- ES PEG684A

D CN2

A1/4

DEH-80PRS/XNUC

# A-b 1/4

## A1/4 TUNER AMP UNIT (SYSTEM BLOCK)

REFERENCE AREA MAP			
251-270	PRE OUT	401-460	FM/AM TUNER
271-300	POWER AMP	521-550	BLUETOOTH
301-310	MUTE	601-700	SYSTEM uCOM
331-350	ASL	801-820	KEYBOARD I/F
351-370	REAR AUX/OEM IN	821-830	FLAP ILM
371-390	AEQ/FRONT AUX	981-999	SENSE

HiOUT Output  
 FM/AM(30%) (UC, ES):+0.12 dBs  
 FM/AM(30%) (EWS):+4.12 dBs  
 CD DIGITAL(S11.6STD):+16.00 dBs  
 USB/SD:+16.00 dBs  
 BT AUDIO/PHONE:+16.00 dBs  
 FRONT AUX IN:+16.33 dBs  
 REAR AUX IN(H):+16.39 dBs  
 REAR AUX IN(L):+16.33 dBs

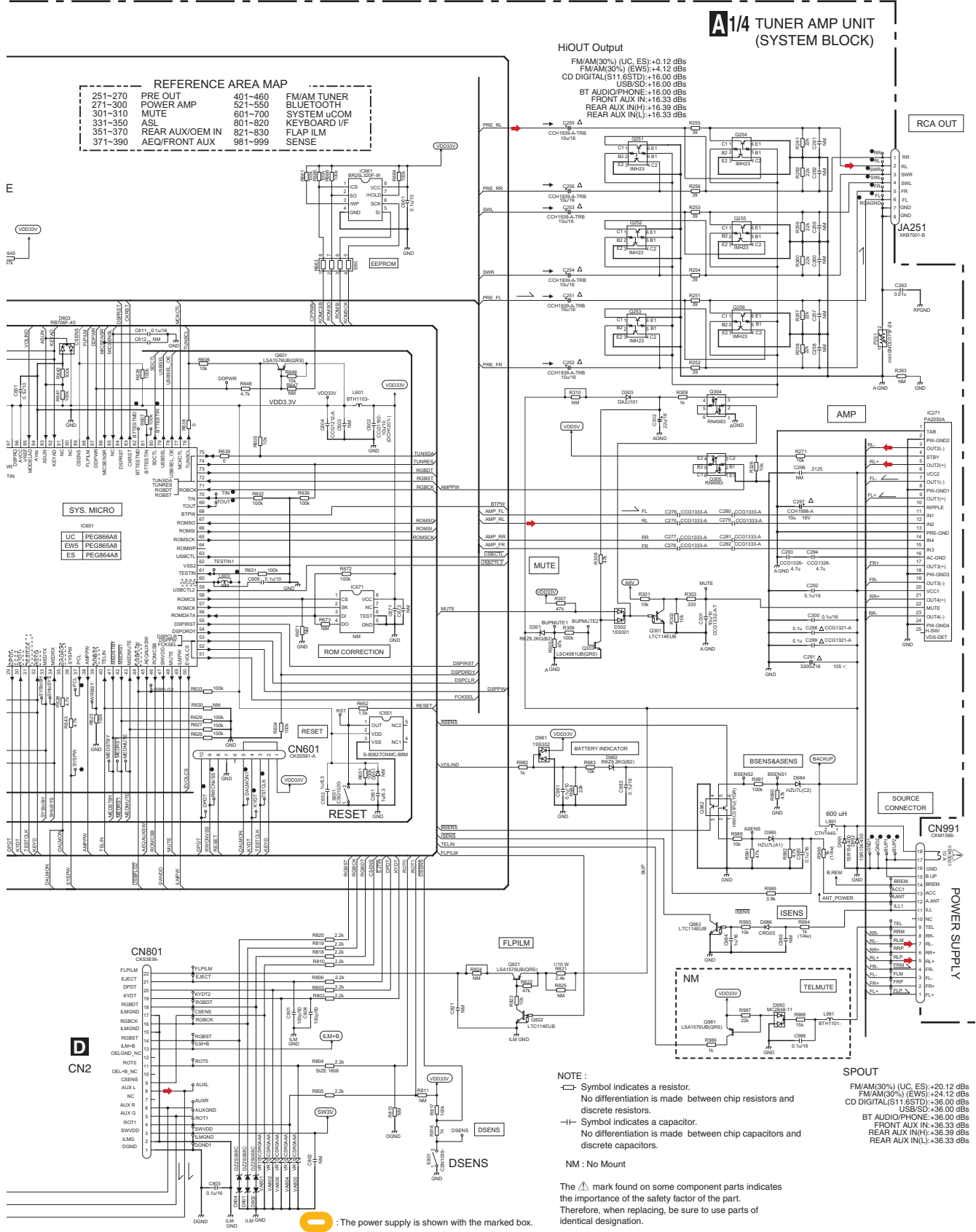

NOTE :  
 □ Symbol indicates a resistor.  
 No differentiation is made between chip resistors and discrete resistors.  
 ▭ Symbol indicates a capacitor.  
 No differentiation is made between chip capacitors and discrete capacitors.  
 NM : No Mount

The  $\Delta$  mark found on some component parts indicates the importance of the safety factor of the part. Therefore, when replacing, be sure to use parts of identical designation.

: The power supply is shown with the marked box.

# A1/4

# A1/4 TUNER AMP UNIT (SYSTEM BLOCK)

HiOUT Output

- FM/AM(30%)(UC,ES)+0.12 dBs
- FM/AM(30%)(EW5)+4.12 dBs
- CD DIGITAL(S11.6STD)+16.00 dBs
- USB/SD+16.00 dBs
- BT AUDIO/PHONE+16.00 dBs
- FRONT AUX IN+16.33 dBs
- REAR AUX IN(H)+16.39 dBs
- REAR AUX IN(L)+16.33 dBs

REFERENCE AREA MAP	
251~270	FM/AM TUNER
271~300	BLUETOOTH
301~310	MUTE
311~350	SYSTEM uCOM
351~370	KEYBOARD I/F
371~390	FLAP ILM
	SENSE
401~460	FM/AM TUNER
521~550	BLUETOOTH
601~700	SYSTEM uCOM
801~820	KEYBOARD I/F
821~830	FLAP ILM
981~999	SENSE

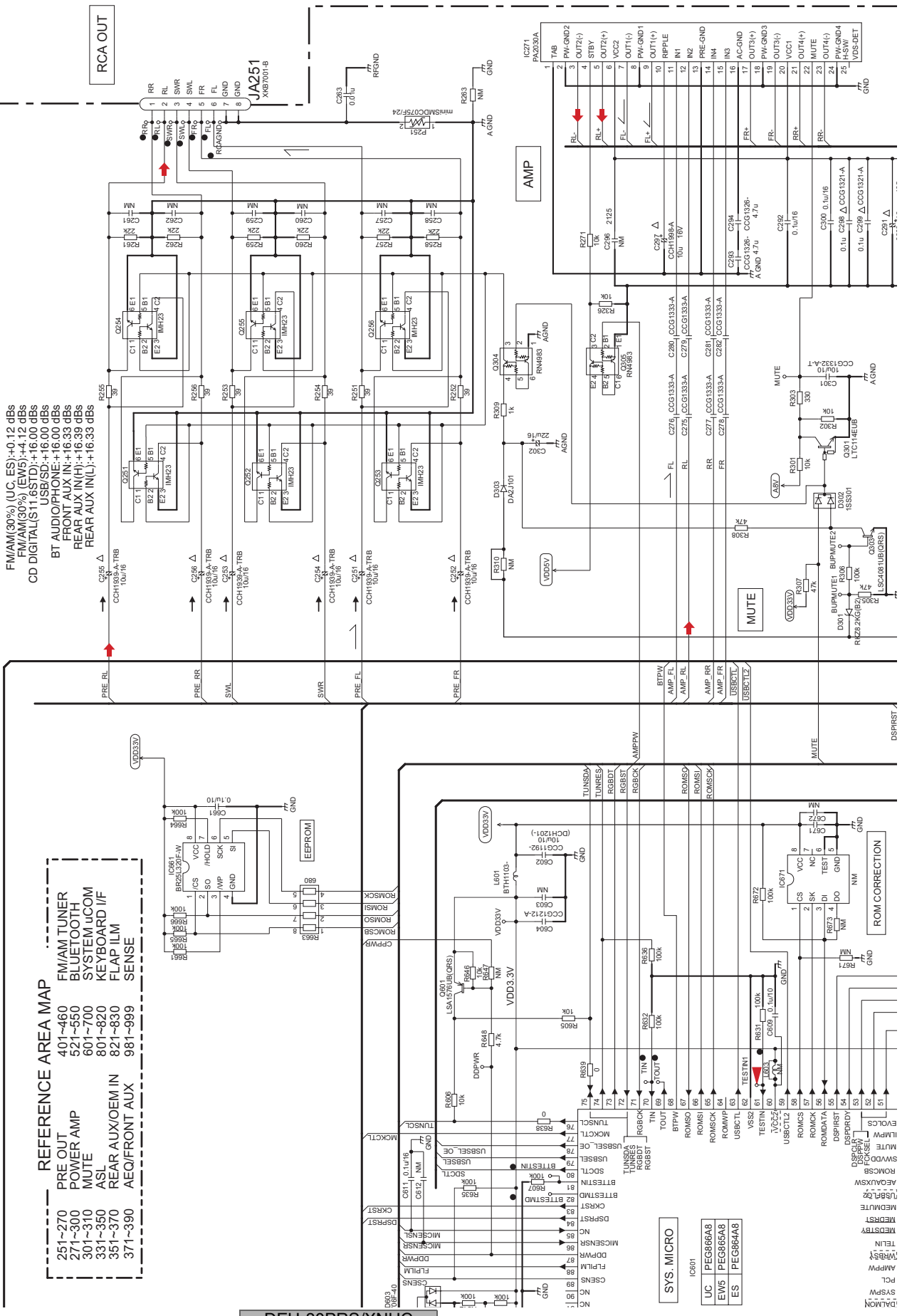

A-a A-b

A-b 1/4

DEH-80PRS/XNUC



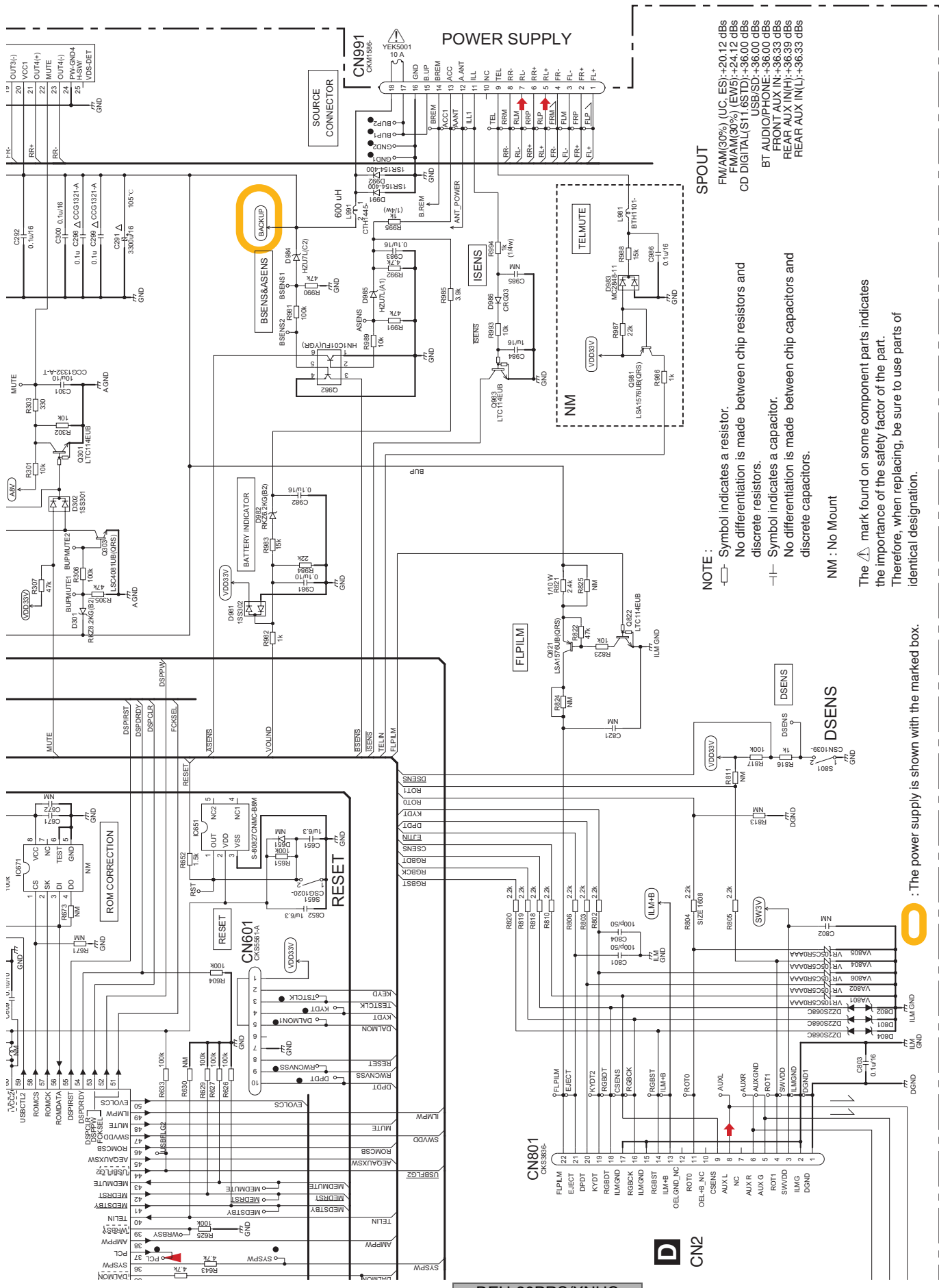

### POWER SUPPLY

### SPOUT

FM/AM(30%) (UC, ES)+20.12 dB  
 FM/AM(30%) (EW5)+24.12 dB  
 CD DIGITAL(S11.65TD)+36.00 dB  
 USB/SD+36.00 dB  
 BT AUDIO/PHONE+36.00 dB  
 FRONT AUX IN+36.33 dB  
 REAR AUX IN(L)+36.39 dB  
 REAR AUX IN(R)+36.33 dB

NOTE :  
 □ Symbol indicates a resistor.  
 □ No differentiation is made between chip resistors and discrete resistors.  
 ⊥ Symbol indicates a capacitor.  
 □ No differentiation is made between chip capacitors and discrete capacitors.

NM : No Mount

The  $\Delta$  mark found on some component parts indicates the importance of the safety factor of the part. Therefore, when replacing, be sure to use parts of identical designation.

○ : The power supply is shown with the marked box.

# A-b 1/4

1 2 3 4

A-b 1/4 A-a 1/4

A B C D E F

The schematic diagram illustrates the internal circuitry of a radio receiver, divided into several functional blocks:

- TUNER:** Located at the top left, it features a JA401 tuner IC and a KN402 diode detector. It includes a 36.48MHz crystal and various tuning-related components like capacitors (C48, C49, C50) and inductors (L40, L41, L42, L43, L44, L45, L46).
- DSP MODE:** A central section containing the DSP51S-40 IC. It includes a 3WAY NETWORK, a 3WAY NET, and a MODE SW. The IC is connected to various control lines and power rails.
- ASL (Automatic Signal Level):** Located at the bottom left, it includes an ASL IC and associated components like resistors (R40, R41, R42, R43, R44, R45, R46, R47, R48, R49, R50, R51, R52, R53, R54, R55, R56, R57, R58, R59, R60, R61, R62, R63, R64, R65, R66, R67, R68, R69, R70, R71, R72, R73, R74, R75, R76, R77, R78, R79, R80, R81, R82, R83, R84, R85, R86, R87, R88, R89, R90, R91, R92, R93, R94, R95, R96, R97, R98, R99, R100) and capacitors (C33, C34, C35, C36, C37, C38, C39, C40, C41, C42, C43, C44, C45, C46, C47, C48, C49, C50, C51, C52, C53, C54, C55, C56, C57, C58, C59, C60, C61, C62, C63, C64, C65, C66, C67, C68, C69, C70, C71, C72, C73, C74, C75, C76, C77, C78, C79, C80, C81, C82, C83, C84, C85, C86, C87, C88, C89, C90, C91, C92, C93, C94, C95, C96, C97, C98, C99, C100).
- ASL IC (ASL):** A detailed sub-circuit at the bottom right, featuring an ASL IC and various components like resistors (R33, R34, R35, R36, R37, R38, R39, R40, R41, R42, R43, R44, R45, R46, R47, R48, R49, R50, R51, R52, R53, R54, R55, R56, R57, R58, R59, R60, R61, R62, R63, R64, R65, R66, R67, R68, R69, R70, R71, R72, R73, R74, R75, R76, R77, R78, R79, R80, R81, R82, R83, R84, R85, R86, R87, R88, R89, R90, R91, R92, R93, R94, R95, R96, R97, R98, R99, R100) and capacitors (C33, C34, C35, C36, C37, C38, C39, C40, C41, C42, C43, C44, C45, C46, C47, C48, C49, C50, C51, C52, C53, C54, C55, C56, C57, C58, C59, C60, C61, C62, C63, C64, C65, C66, C67, C68, C69, C70, C71, C72, C73, C74, C75, C76, C77, C78, C79, C80, C81, C82, C83, C84, C85, C86, C87, C88, C89, C90, C91, C92, C93, C94, C95, C96, C97, C98, C99, C100).
- Other Components:** The diagram includes numerous other components such as resistors (R1, R2, R3, R4, R5, R6, R7, R8, R9, R10, R11, R12, R13, R14, R15, R16, R17, R18, R19, R20, R21, R22, R23, R24, R25, R26, R27, R28, R29, R30, R31, R32, R33, R34, R35, R36, R37, R38, R39, R40, R41, R42, R43, R44, R45, R46, R47, R48, R49, R50, R51, R52, R53, R54, R55, R56, R57, R58, R59, R60, R61, R62, R63, R64, R65, R66, R67, R68, R69, R70, R71, R72, R73, R74, R75, R76, R77, R78, R79, R80, R81, R82, R83, R84, R85, R86, R87, R88, R89, R90, R91, R92, R93, R94, R95, R96, R97, R98, R99, R100), capacitors (C1, C2, C3, C4, C5, C6, C7, C8, C9, C10, C11, C12, C13, C14, C15, C16, C17, C18, C19, C20, C21, C22, C23, C24, C25, C26, C27, C28, C29, C30, C31, C32, C33, C34, C35, C36, C37, C38, C39, C40, C41, C42, C43, C44, C45, C46, C47, C48, C49, C50, C51, C52, C53, C54, C55, C56, C57, C58, C59, C60, C61, C62, C63, C64, C65, C66, C67, C68, C69, C70, C71, C72, C73, C74, C75, C76, C77, C78, C79, C80, C81, C82, C83, C84, C85, C86, C87, C88, C89, C90, C91, C92, C93, C94, C95, C96, C97, C98, C99, C100), and inductors (L1, L2, L3, L4, L5, L6, L7, L8, L9, L10, L11, L12, L13, L14, L15, L16, L17, L18, L19, L20, L21, L22, L23, L24, L25, L26, L27, L28, L29, L30, L31, L32, L33, L34, L35, L36, L37, L38, L39, L40, L41, L42, L43, L44, L45, L46, L47, L48, L49, L50, L51, L52, L53, L54, L55, L56, L57, L58, L59, L60, L61, L62, L63, L64, L65, L66, L67, L68, L69, L70, L71, L72, L73, L74, L75, L76, L77, L78, L79, L80, L81, L82, L83, L84, L85, L86, L87, L88, L89, L90, L91, L92, L93, L94, L95, L96, L97, L98, L99, L100).

DEH-80PRS/XNUC

1 2 3 4

50

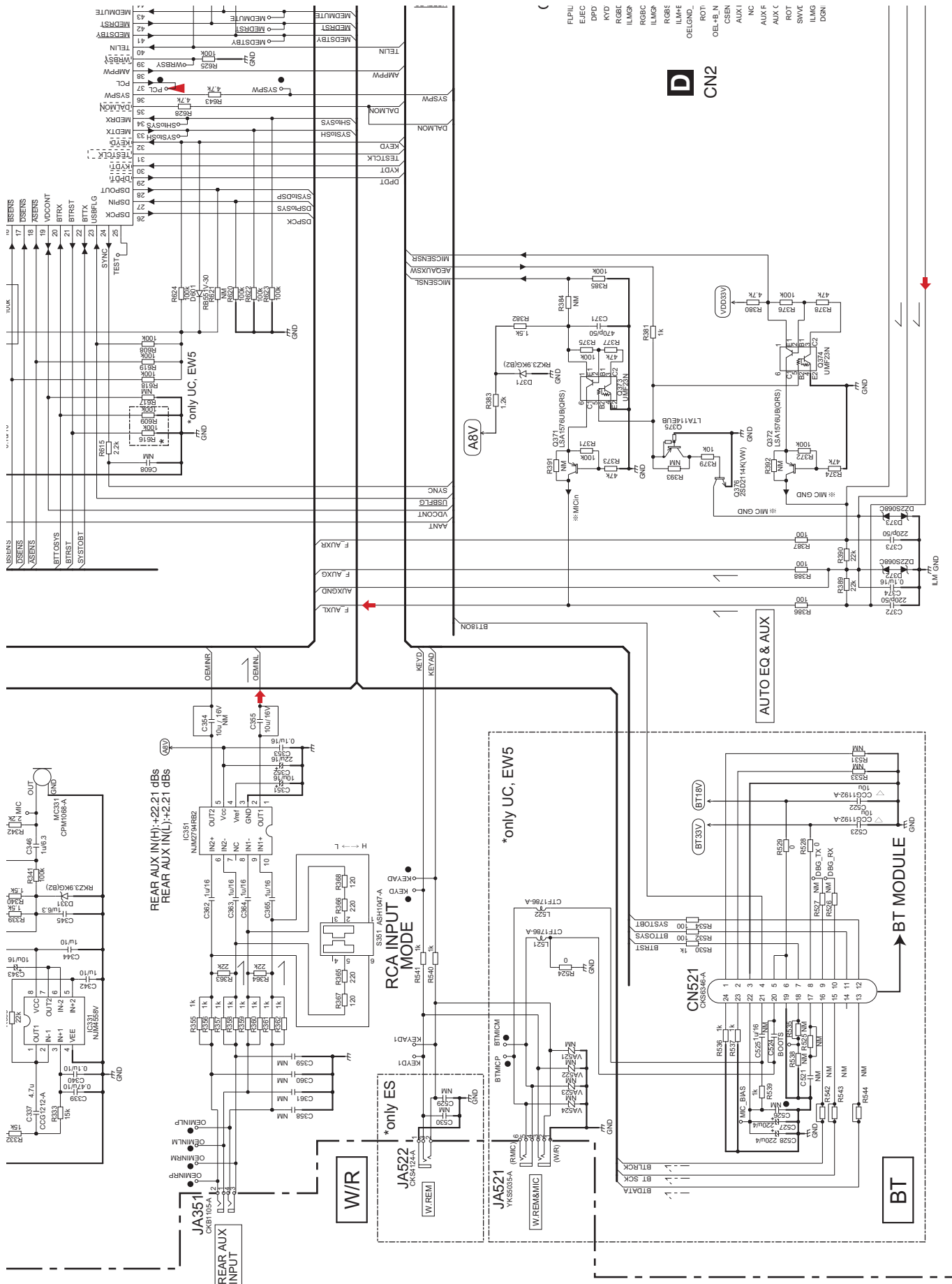

# 10.2 TUNER AMP UNIT (MEDIA BLOCK) (GUIDE PAGE)

A-a 2/4

A

B

C

D

E

F

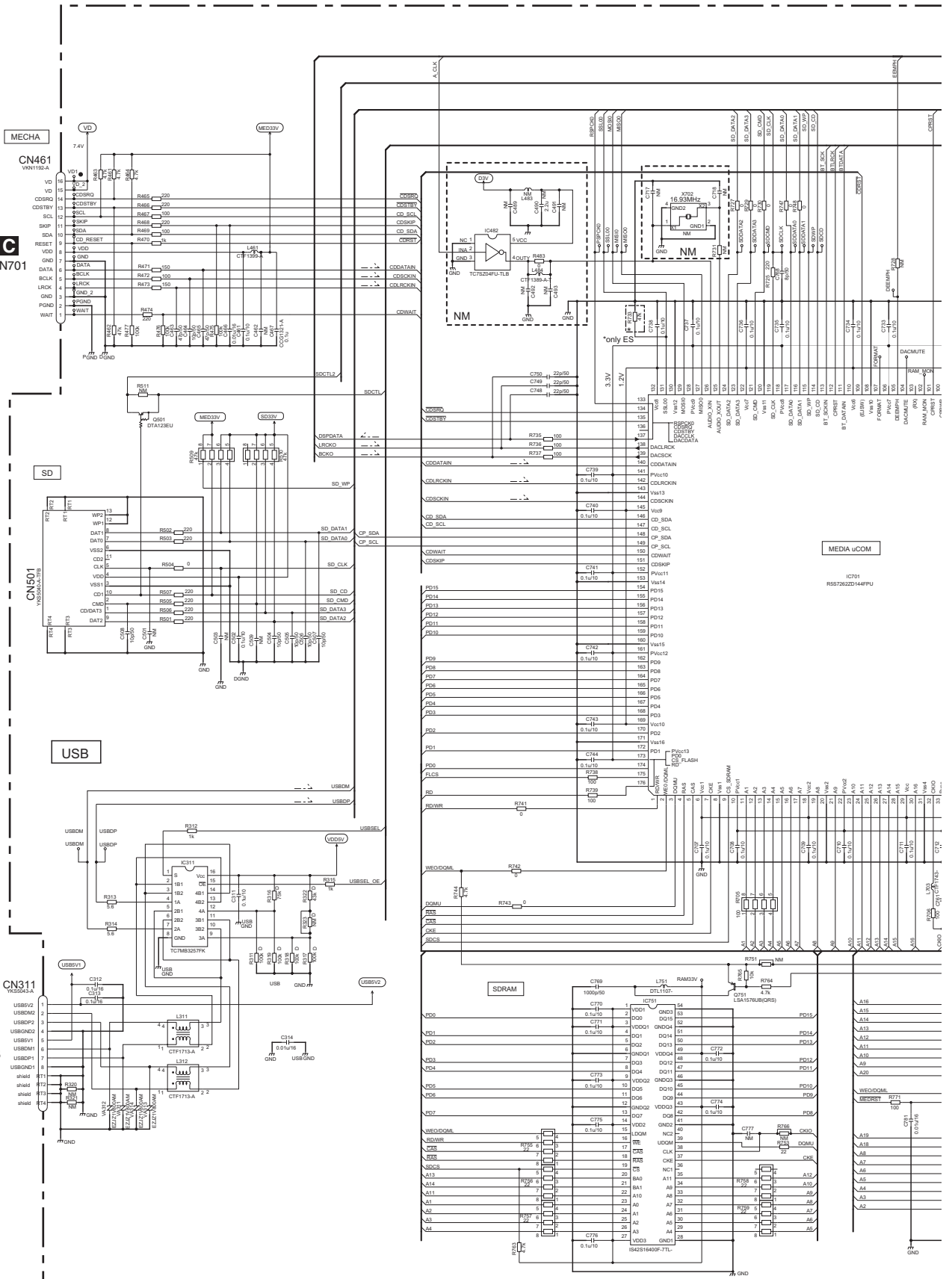

A2/4

DEH-80PRS/XNUC

# A-b 2/4

## A2/4 TUNER AMP UNIT (MEDIA BLOCK)

A3/4 A4/4 A1/4

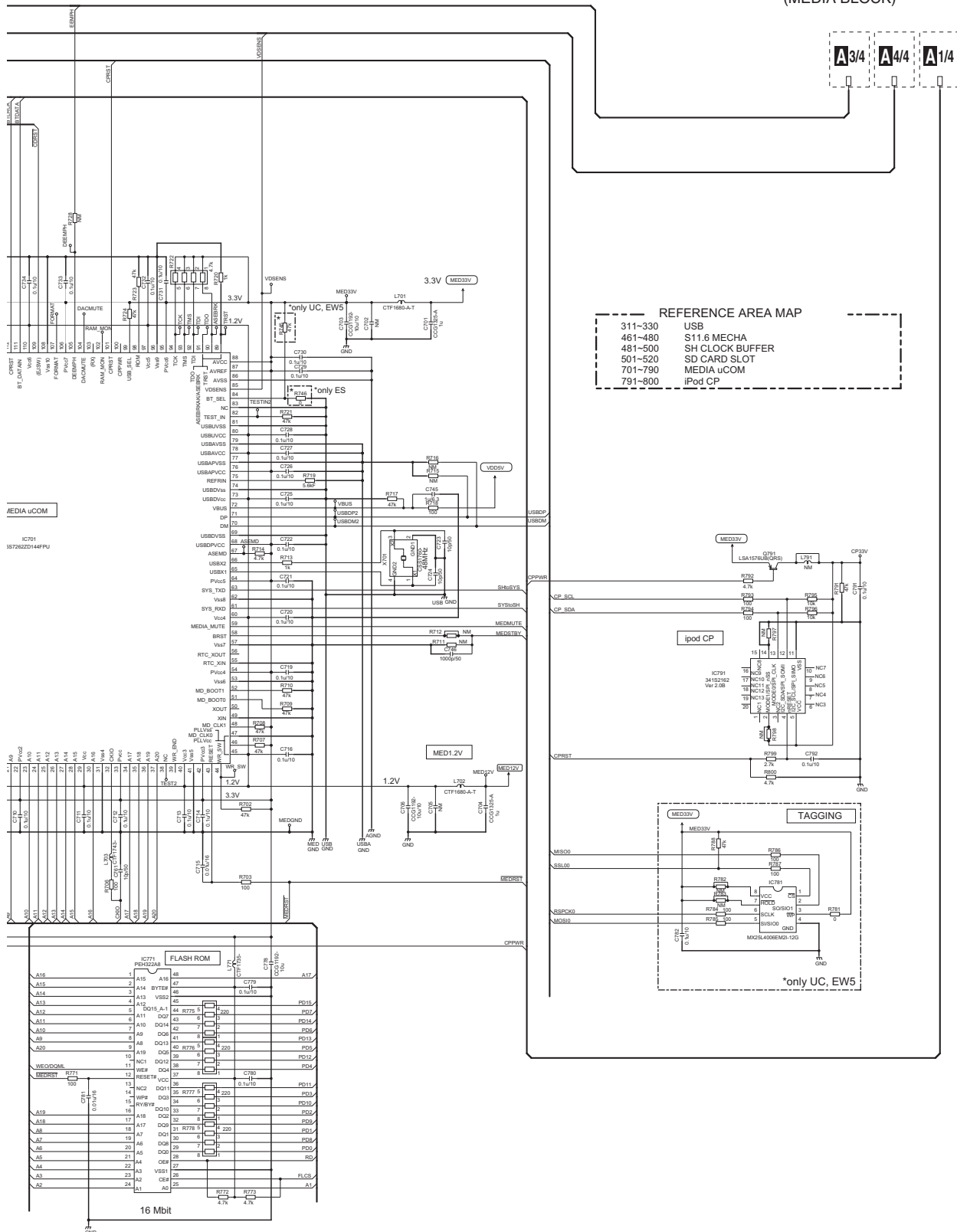

**REFERENCE AREA MAP**

- 311-330 USB
- 461-480 S11.6 MECHA
- 481-500 SH CLOCK BUFFER
- 501-520 SD CARD SLOT
- 701-790 MEDIA uCOM
- 791-800 iPod CP

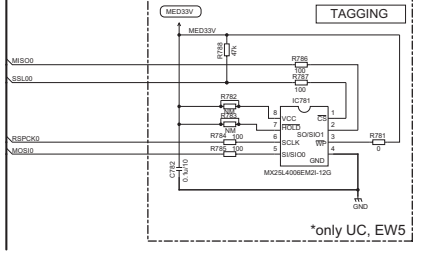
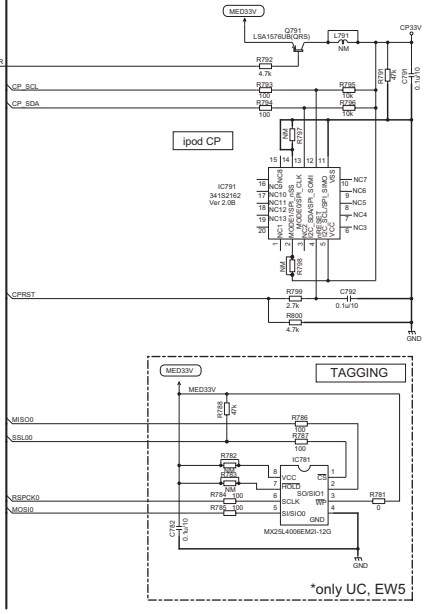

MEDIA uCOM

IC701 SP7262ZD14FPU

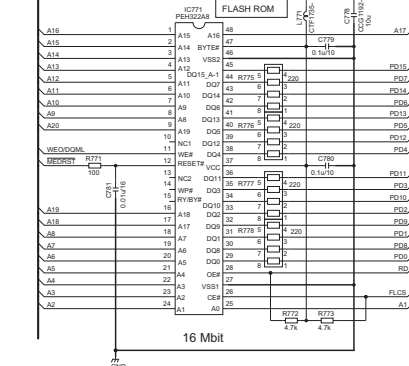

16 Mbit

# A2/4 TUNER AMP UNIT (MEDIA BLOCK)

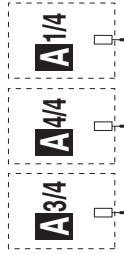

## REFERENCE AREA MAP

- 311~330 USB
- 461~480 S11.6 MECHA
- 481~500 SH CLOCK BUFFER
- 501~520 SD CARD SLOT
- 701~790 MEDIA uCOM
- 791~800 iPod CP

A-a    A-b

# A-b 2/4

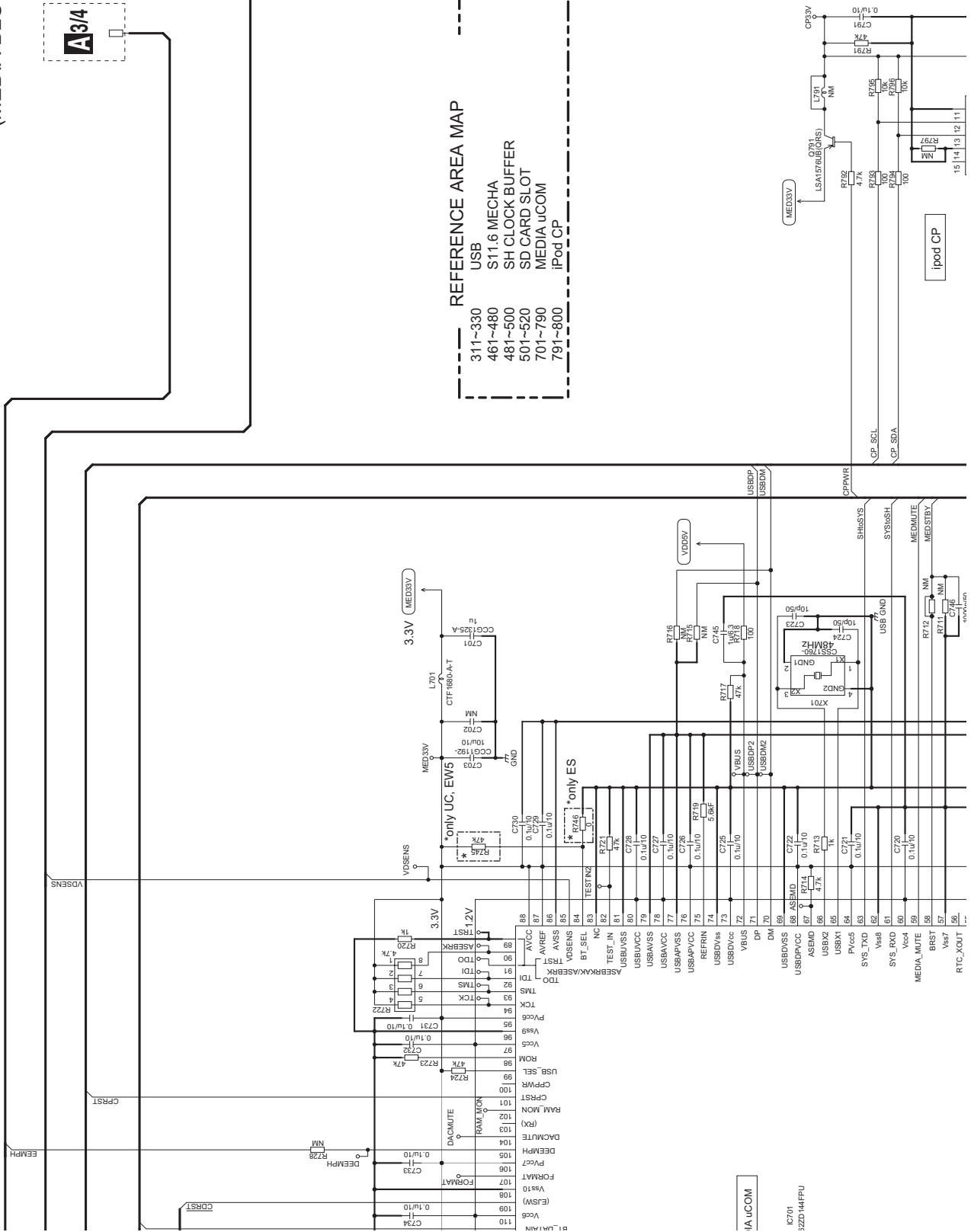

DEH-80PRS/XNUC

1A uCOM

K701  
3ZSD144FFPU

iPod CP

A  
B  
C  
D  
E  
F

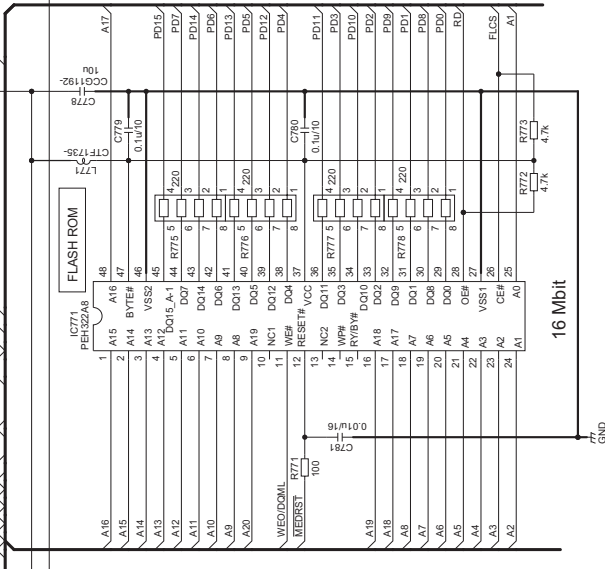
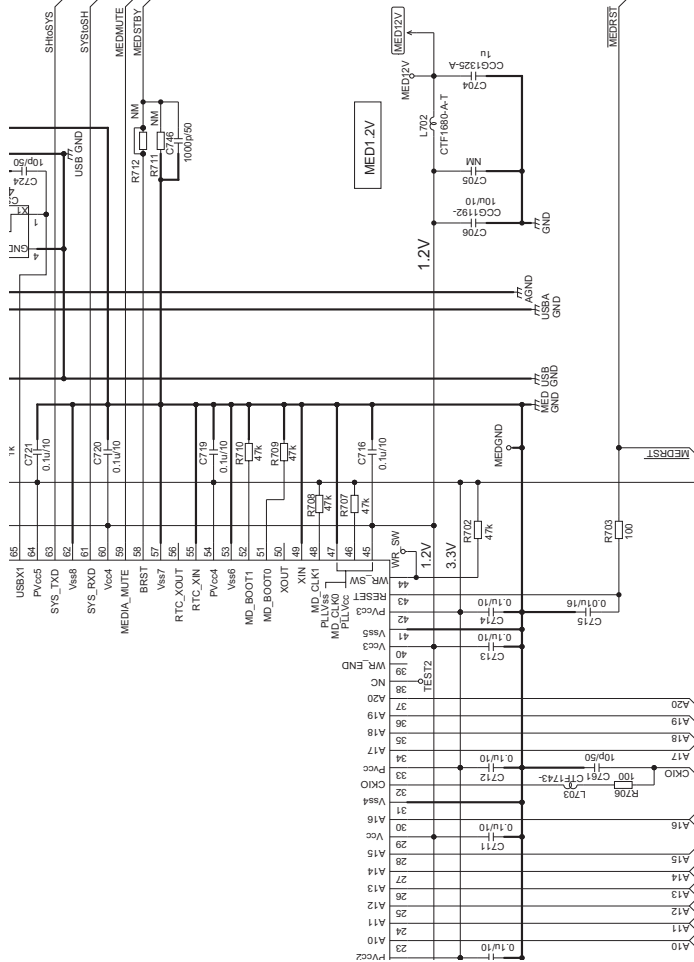
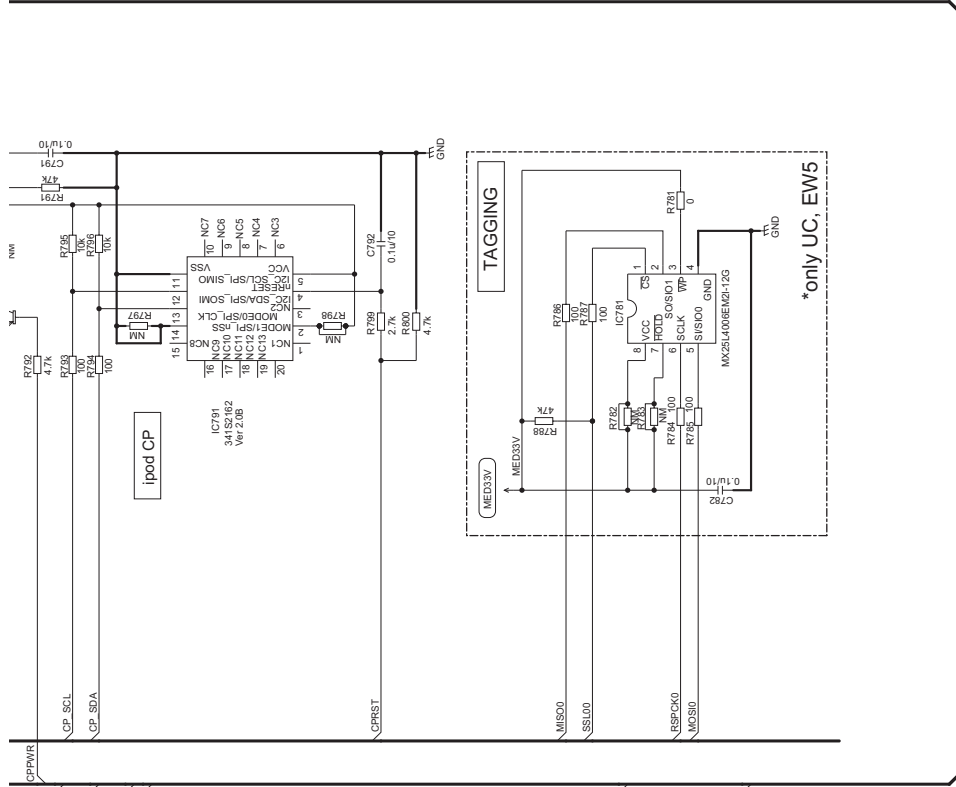

DEH-80PRS/XNUC

A-b 2/4

A-a A-b

A B C D E F

1

2

3

4

A-b 2/4

A

B

C

D

E

F

A-a A-b

A-a 2/4

DEH-80PRS/XNUC

The schematic diagram illustrates the electrical connections between several key components on the PCB:

- Connectors:**
  - CN461 (VKN1192-A):** A 16-pin connector with signals including VD (7.4V), VDD, VSS, SCL, SDA, RESET, CD\_RESET, WAIT, and various data lines (DATA, BCLK, LCK, GND, PWD).
  - CN701:** A 16-pin connector with signals including VDD, VSS, SCL, SDA, RESET, CD\_RESET, WAIT, and various data lines (DATA, BCLK, LCK, GND, PWD).
  - CN501 (VKS5040-A-1TB):** A 14-pin connector with signals including WP1, WP2, DAT0, DAT1, DAT2, DAT3, CLK, VDD, VSS, CMD, and various data lines (DATA, BCLK, LCK, GND, PWD).
- ICs and Components:**
  - X702:** A 1.93MHz oscillator with a 10kΩ pull-up resistor (R727) and a 100nF capacitor (C718).
  - TCS220H-L1B:** A color sensor with a 4.7kΩ pull-up resistor (R462) and a 100nF capacitor (C491).
  - Resistors:** Various resistors (R462, R463, R464, R465, R466, R467, R468, R469, R470, R471, R472, R473, R474, R475, R476, R477, R478, R479, R480, R481, R482, R483, R484, R485, R486, R487, R488, R489, R490, R491, R492, R493, R494, R495, R496, R497, R498, R499, R500, R501, R502, R503, R504, R505, R506, R507, R508, R509, R510, R511, R512, R513, R514, R515, R516, R517, R518, R519, R520, R521, R522, R523, R524, R525, R526, R527, R528, R529, R530, R531, R532, R533, R534, R535, R536, R537, R538, R539, R540, R541, R542, R543, R544, R545, R546, R547, R548, R549, R550, R551, R552, R553, R554, R555, R556, R557, R558, R559, R560, R561, R562, R563, R564, R565, R566, R567, R568, R569, R570, R571, R572, R573, R574, R575, R576, R577, R578, R579, R580, R581, R582, R583, R584, R585, R586, R587, R588, R589, R590, R591, R592, R593, R594, R595, R596, R597, R598, R599, R600, R601, R602, R603, R604, R605, R606, R607, R608, R609, R610, R611, R612, R613, R614, R615, R616, R617, R618, R619, R620, R621, R622, R623, R624, R625, R626, R627, R628, R629, R630, R631, R632, R633, R634, R635, R636, R637, R638, R639, R640, R641, R642, R643, R644, R645, R646, R647, R648, R649, R650, R651, R652, R653, R654, R655, R656, R657, R658, R659, R660, R661, R662, R663, R664, R665, R666, R667, R668, R669, R670, R671, R672, R673, R674, R675, R676, R677, R678, R679, R680, R681, R682, R683, R684, R685, R686, R687, R688, R689, R690, R691, R692, R693, R694, R695, R696, R697, R698, R699, R700, R701, R702, R703, R704, R705, R706, R707, R708, R709, R710, R711, R712, R713, R714, R715, R716, R717, R718, R719, R720, R721, R722, R723, R724, R725, R726, R727, R728, R729, R730, R731, R732, R733, R734, R735, R736, R737, R738, R739, R740, R741, R742, R743, R744, R745, R746, R747, R748, R749, R750, R751, R752, R753, R754, R755, R756, R757, R758, R759, R760, R761, R762, R763, R764, R765, R766, R767, R768, R769, R770, R771, R772, R773, R774, R775, R776, R777, R778, R779, R780, R781, R782, R783, R784, R785, R786, R787, R788, R789, R790, R791, R792, R793, R794, R795, R796, R797, R798, R799, R800, R801, R802, R803, R804, R805, R806, R807, R808, R809, R810, R811, R812, R813, R814, R815, R816, R817, R818, R819, R820, R821, R822, R823, R824, R825, R826, R827, R828, R829, R830, R831, R832, R833, R834, R835, R836, R837, R838, R839, R840, R841, R842, R843, R844, R845, R846, R847, R848, R849, R850, R851, R852, R853, R854, R855, R856, R857, R858, R859, R860, R861, R862, R863, R864, R865, R866, R867, R868, R869, R870, R871, R872, R873, R874, R875, R876, R877, R878, R879, R880, R881, R882, R883, R884, R885, R886, R887, R888, R889, R890, R891, R892, R893, R894, R895, R896, R897, R898, R899, R900, R901, R902, R903, R904, R905, R906, R907, R908, R909, R910, R911, R912, R913, R914, R915, R916, R917, R918, R919, R920, R921, R922, R923, R924, R925, R926, R927, R928, R929, R930, R931, R932, R933, R934, R935, R936, R937, R938, R939, R940, R941, R942, R943, R944, R945, R946, R947, R948, R949, R950, R951, R952, R953, R954, R955, R956, R957, R958, R959, R960, R961, R962, R963, R964, R965, R966, R967, R968, R969, R970, R971, R972, R973, R974, R975, R976, R977, R978, R979, R980, R981, R982, R983, R984, R985, R986, R987, R988, R989, R990, R991, R992, R993, R994, R995, R996, R997, R998, R999, R1000).
  - Capacitors:** Various capacitors (C489, C490, C491, C492, C493, C494, C495, C496, C497, C498, C499, C500, C501, C502, C503, C504, C505, C506, C507, C508, C509, C510, C511, C512, C513, C514, C515, C516, C517, C518, C519, C520, C521, C522, C523, C524, C525, C526, C527, C528, C529, C530, C531, C532, C533, C534, C535, C536, C537, C538, C539, C540, C541, C542, C543, C544, C545, C546, C547, C548, C549, C550, C551, C552, C553, C554, C555, C556, C557, C558, C559, C560, C561, C562, C563, C564, C565, C566, C567, C568, C569, C570, C571, C572, C573, C574, C575, C576, C577, C578, C579, C580, C581, C582, C583, C584, C585, C586, C587, C588, C589, C590, C591, C592, C593, C594, C595, C596, C597, C598, C599, C600, C601, C602, C603, C604, C605, C606, C607, C608, C609, C610, C611, C612, C613, C614, C615, C616, C617, C618, C619, C620, C621, C622, C623, C624, C625, C626, C627, C628, C629, C630, C631, C632, C633, C634, C635, C636, C637, C638, C639, C640, C641, C642, C643, C644, C645, C646, C647, C648, C649, C650, C651, C652, C653, C654, C655, C656, C657, C658, C659, C660, C661, C662, C663, C664, C665, C666, C667, C668, C669, C670, C671, C672, C673, C674, C675, C676, C677, C678, C679, C680, C681, C682, C683, C684, C685, C686, C687, C688, C689, C690, C691, C692, C693, C694, C695, C696, C697, C698, C699, C700, C701, C702, C703, C704, C705, C706, C707, C708, C709, C710, C711, C712, C713, C714, C715, C716, C717, C718, C719, C720, C721, C722, C723, C724, C725, C726, C727, C728, C729, C730, C731, C732, C733, C734, C735, C736, C737, C738, C739, C740, C741, C742, C743, C744, C745, C746, C747, C748, C749, C750, C751, C752, C753, C754, C755, C756, C757, C758, C759, C760, C761, C762, C763, C764, C765, C766, C767, C768, C769, C770, C771, C772, C773, C774, C775, C776, C777, C778, C779, C780, C781, C782, C783, C784, C785, C786, C787, C788, C789, C790, C791, C792, C793, C794, C795, C796, C797, C798, C799, C800, C801, C802, C803, C804, C805, C806, C807, C808, C809, C810, C811, C812, C813, C814, C815, C816, C817, C818, C819, C820, C821, C822, C823, C824, C825, C826, C827, C828, C829, C830, C831, C832, C833, C834, C835, C836, C837, C838, C839, C840, C841, C842, C843, C844, C845, C846, C847, C848, C849, C850, C851, C852, C853, C854, C855, C856, C857, C858, C859, C860, C861, C862, C863, C864, C865, C866, C867, C868, C869, C870, C871, C872, C873, C874, C875, C876, C877, C878, C879, C880, C881, C882, C883, C884, C885, C886, C887, C888, C889, C890, C891, C892, C893, C894, C895, C896, C897, C898, C899, C900, C901, C902, C903, C904, C905, C906, C907, C908, C909, C910, C911, C912, C913, C914, C915, C916, C917, C918, C919, C920, C921, C922, C923, C924, C925, C926, C927, C928, C929, C930, C931, C932, C933, C934, C935, C936, C937, C938, C939, C940, C941, C942, C943, C944, C945, C946, C947, C948, C949, C950, C951, C952, C953, C954, C955, C956, C957, C958, C959, C960, C961, C962, C963, C964, C965, C966, C967, C968, C969, C970, C971, C972, C973, C974, C975, C976, C977, C978, C979, C980, C981, C982, C983, C984, C985, C986, C987, C988, C989, C990, C991, C992, C993, C994, C995, C996, C997, C998, C999, C1000).

1

2

3

4

56



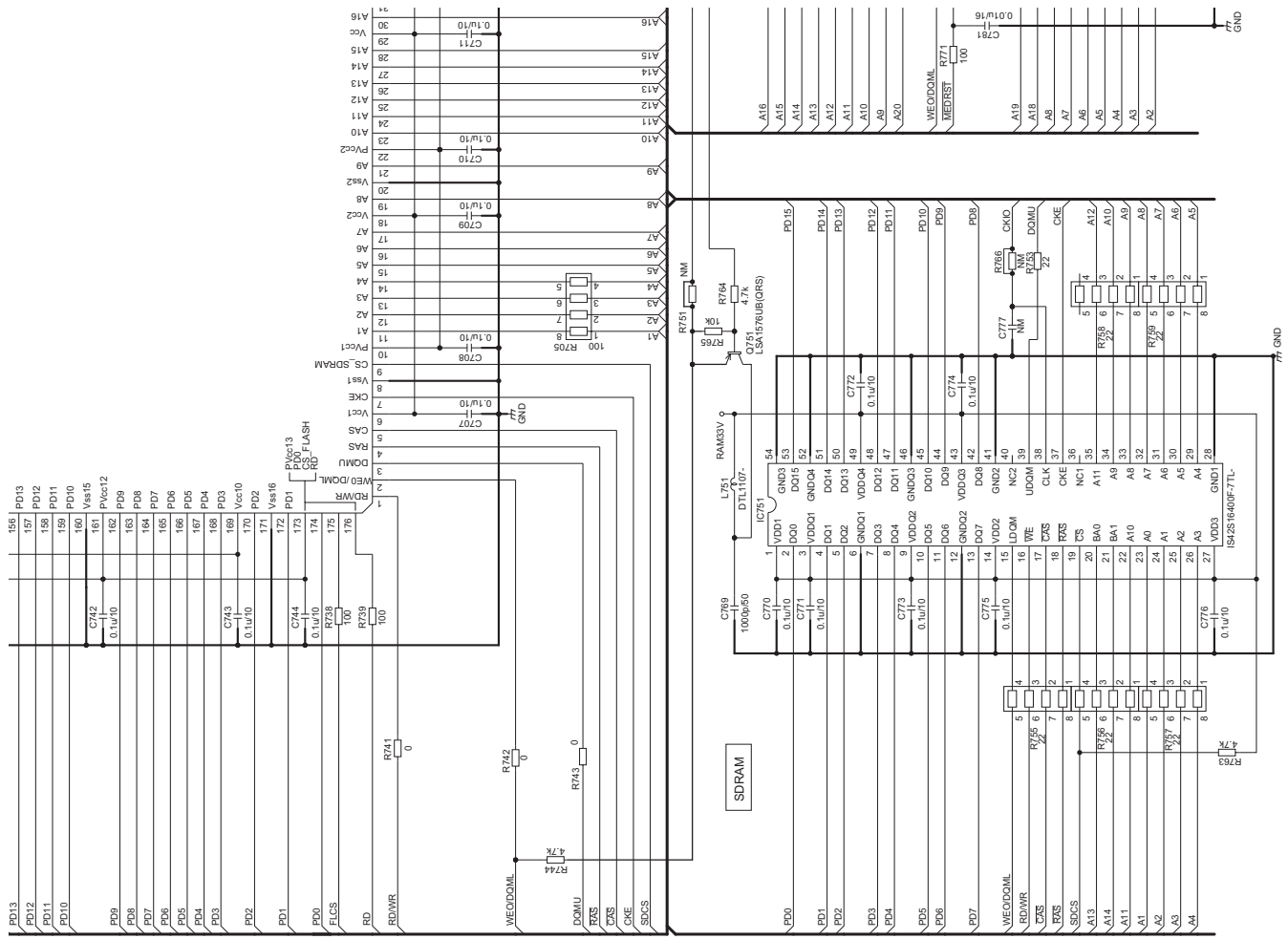
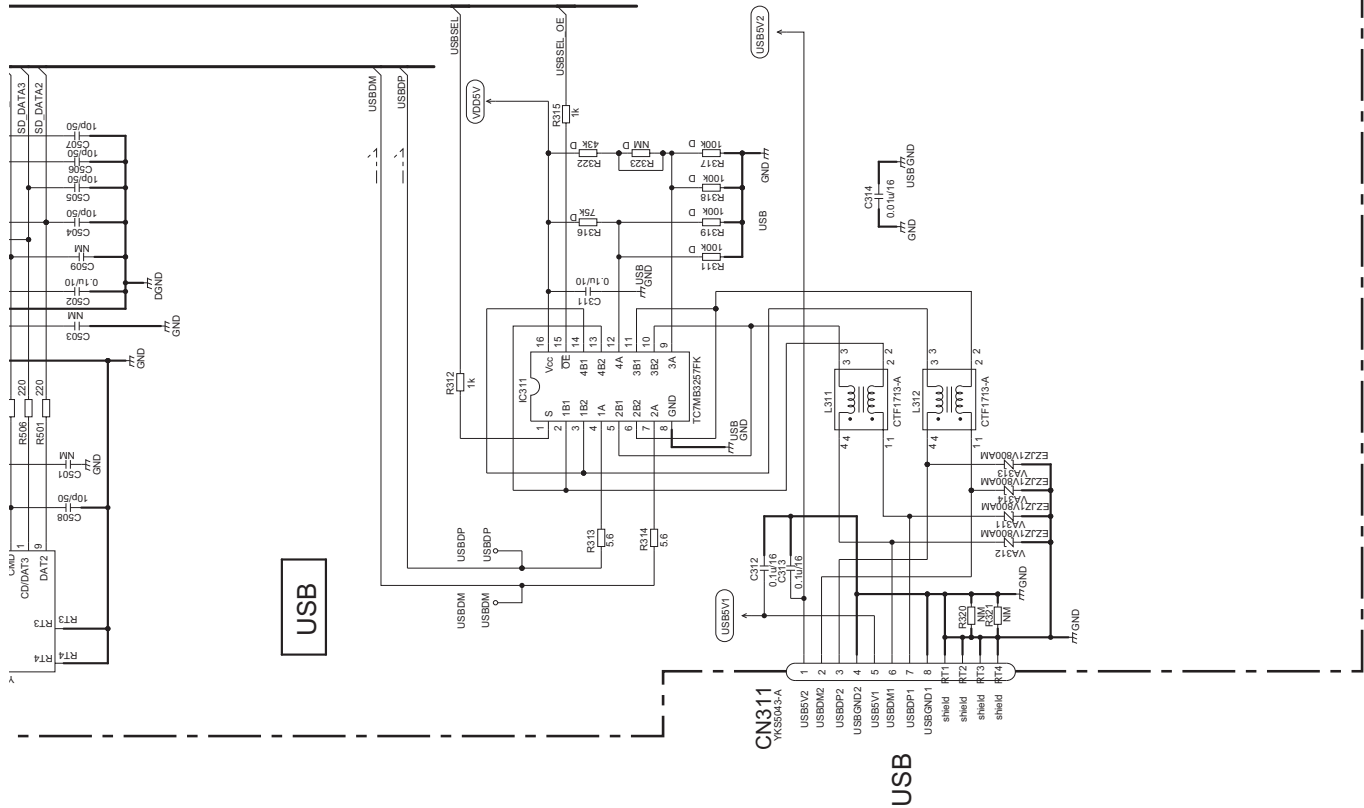

A-a A-b

A-b 2/4

# 10.3 TUNER AMP UNIT (DSP BLOCK) (GUIDE PAGE)

A-a 3/4

**DSP Input**

- FM/AM(30%) (UC, ES): -15.35 dBs
- FM/AM(30%) (EWS): -11.35 dBs
- FRONT AUX IN: +0.86 dBs
- REAR AUX IN(H): +0.92 dBs
- REAR AUX IN(L): +0.86 dBs
- A-EQ: +23.78 dBs

**DAC Output**

- FM/AM(30%) (UC, ES): -13.68 dBs
- FM/AM(30%) (EWS): -9.68 dBs
- CD DIGITAL(S11.6STD): +3.20 dBs
- USB/SD: +3.20 dBs
- FRONT AUX IN: +3.20 dBs
- FRONT AUX IN(H): +2.53 dBs
- REAR AUX IN(L): +2.59 dBs
- REAR AUX IN(H): +2.53 dBs

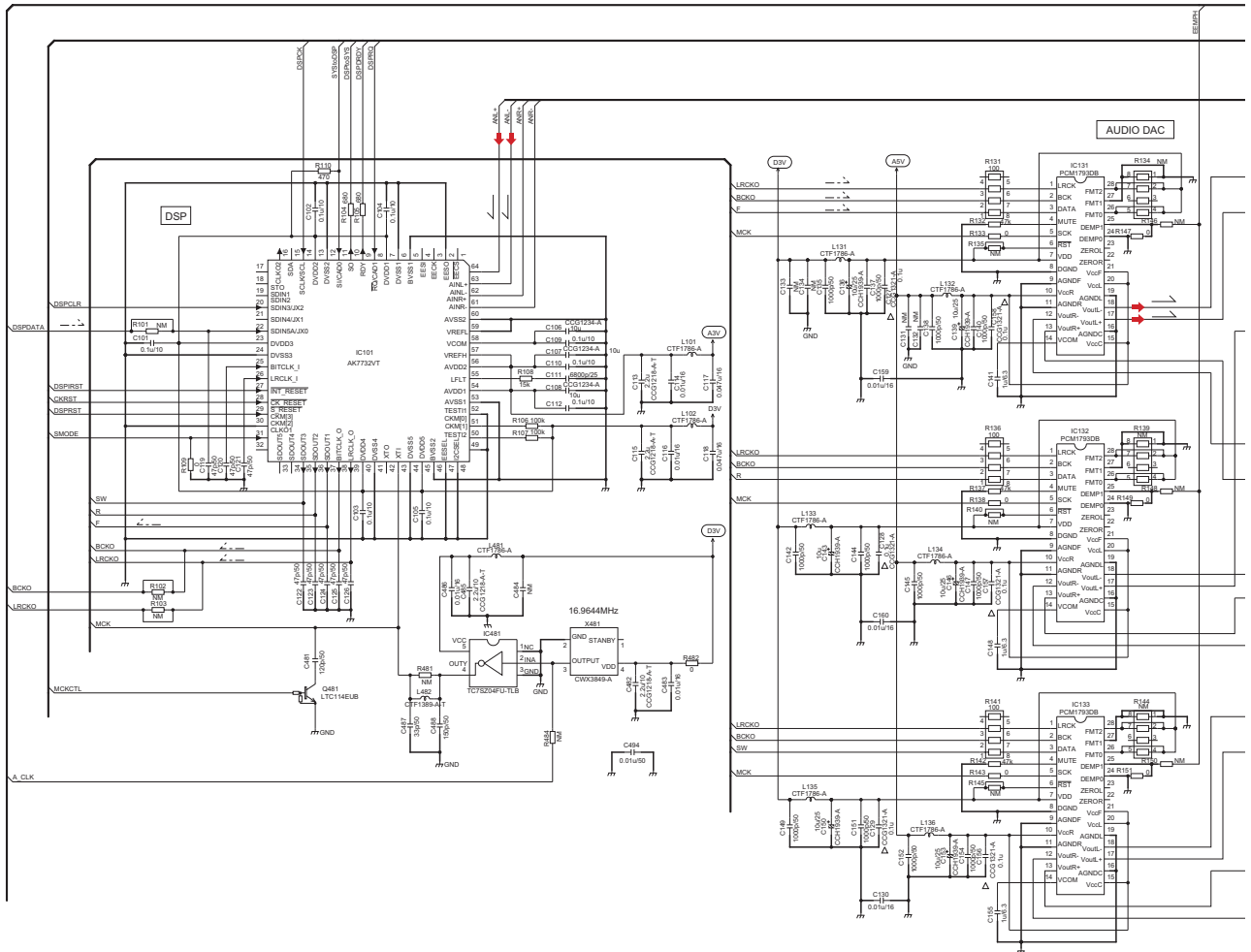

# A-b 3/4

## A3/4 TUNER AMP UNIT (DSP BLOCK)

REFERENCE AREA MAP	
101-130	DSP
131-160	DA CONVERTER
161-200	POST LPF
201-210	AD INPUT BUFFER
211-240	EVO/MIC AMP
241-250	BIAS BUFFER

(UC, ES): -13.68 dBs  
 (%) (EW5): -9.68 dBs  
 11.6STD): +3.20 dBs  
 USB/SD: +3.20 dBs  
 )PHONE: +3.20 dBs  
 T AUX IN: +2.53 dBs  
 UX IN(H): +2.59 dBs  
 AUX IN(L): +2.53 dBs

A2/4  
 A1/4

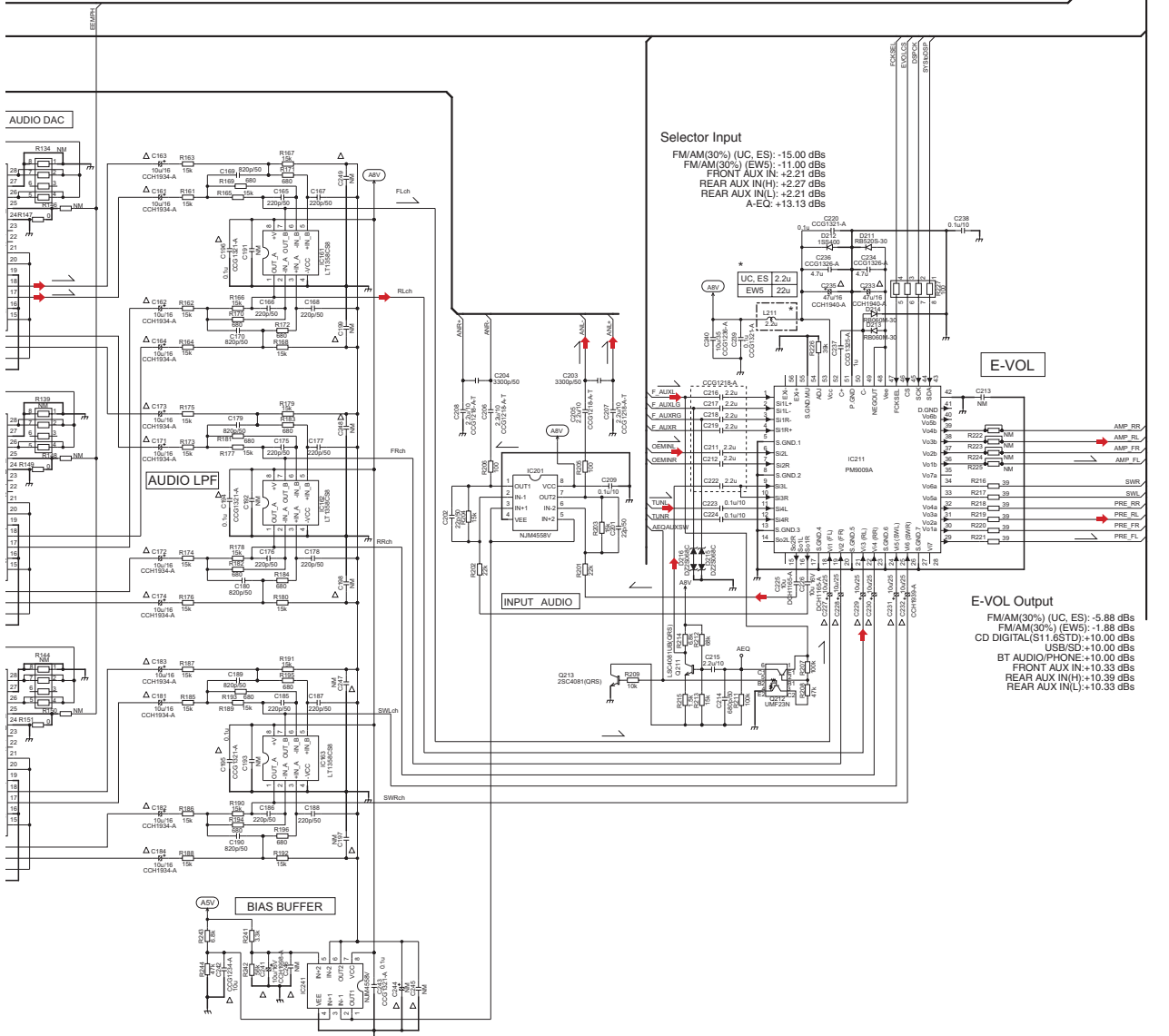

Selector Input  
 FM/AM(30%) (UC, ES): -15.00 dBs  
 FM/AM(30%) (EW5): -11.00 dBs  
 FRONT AUX IN: +2.21 dBs  
 REAR AUX IN(H): +2.27 dBs  
 REAR AUX IN(L): +2.21 dBs  
 A-EQ: +13.13 dBs

E-VOL

E-VOL Output  
 FM/AM(30%) (UC, ES): -5.88 dBs  
 FM/AM(30%) (EW5): -1.88 dBs  
 CD DIGITAL(S11.6STD): +10.00 dBs  
 USB/SD: +10.00 dBs  
 BT AUDIO/PHONE: +10.00 dBs  
 FRONT AUX IN: +10.33 dBs  
 REAR AUX IN(H): +10.33 dBs  
 REAR AUX IN(L): +10.33 dBs

**A-b 3/4**

A-a A-b

**A3/4** TUNER AMP UNIT  
(DSP BLOCK)

REFERENCE AREA MAP

101~130	DSP
131~160	DA CONVERTER
161~200	POST LPF
201~210	AD INPUT BUFFER
211~240	EVOL/MIC AMP
241~250	BIAS BUFFER

IC, ES); -13.68 dBs  
 ) (EW5); -9.68 dBs  
 I (6STD); +3.20 dBs  
 JSB/SD; +3.20 dBs  
 PHONE; +3.20 dBs  
 AUX IN; +2.53 dBs  
 X IN(H); +2.59 dBs  
 X IN(L); +2.53 dBs

DEH-80PRS/XNUC

**A1/4**  
**A2/4**

AUDIO DAC

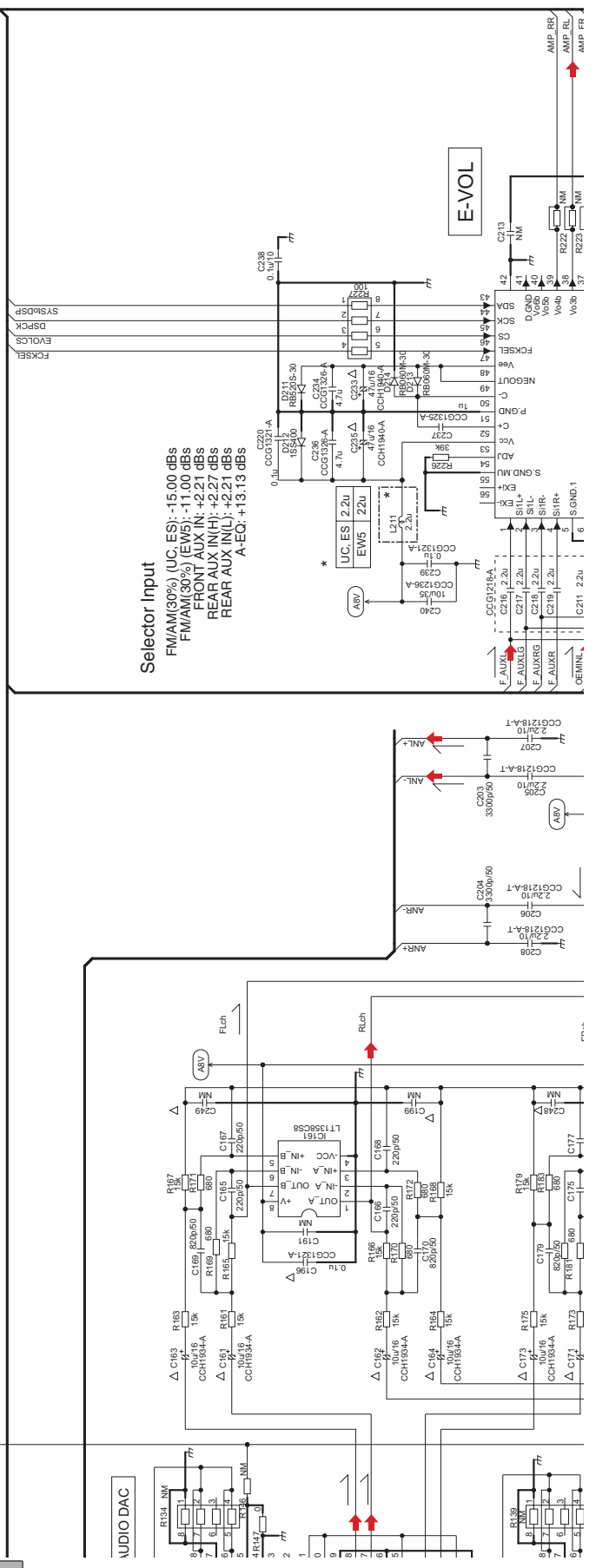

Selector Input

FM/AM(30%) (UC, ES); -15.00 dBs  
 FM/AM(30%) (EW5); -11.00 dBs  
 FRONT AUX IN; +2.21 dBs  
 REAR AUX IN(H); +2.27 dBs  
 REAR AUX IN(L); +2.21 dBs  
 A-EQ; +13.13 dBs

E-VOL

AMP RR  
AMP FR

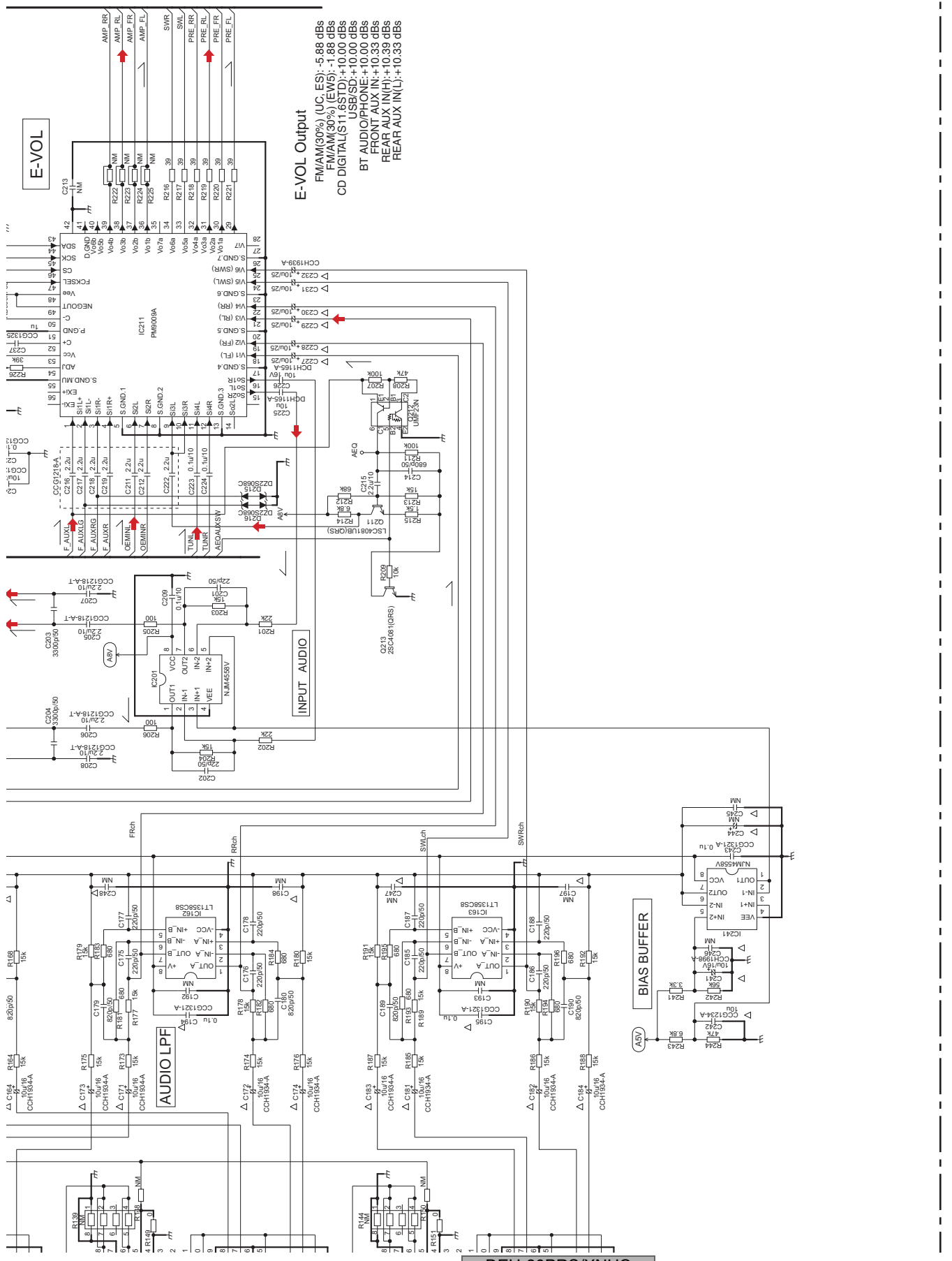

**E-VOL Output**  
 FM/AM(30%) (UC, ES): -5.88 dBs  
 FM/AM(30%) (EWS): -1.88 dBs  
 CD DIGITAL(S11.6STD): +10.00 dBs  
 USB/SD: +10.00 dBs  
 BT AUDIO/PHONE: +10.00 dBs  
 FRONT AUX IN: +10.33 dBs  
 REAR AUX IN(H): +10.39 dBs  
 REAR AUX IN(L): +10.33 dBs

A-a A-b

D

A-b 3/4

**DSP Input**  
 FM/AM(30%) (UC, ES): -15.35 dBs  
 FM/AM(30%) (EW5): -11.35 dBs  
 FRONT AUX IN: +0.86 dBs  
 REAR AUX IN(H): +0.92 dBs  
 REAR AUX IN(L): +0.86 dBs  
 A-EQ: +23.78 dBs

**DAC Output**  
 FM/AM(30%) (UC, ES): -13.68 dBs  
 FM/AM(30%) (EW5): -9.68 dBs  
 CD DIGITAL(S11,6STD): +3.20 dBs  
 USB/SD: +3.20 dBs  
 BT AUDIO/PHONE: +3.20 dBs  
 FRONT AUX IN: +2.53 dBs  
 REAR AUX IN(H): +2.59 dBs  
 REAR AUX IN(L): +2.53 dBs

**DSP**  
 FM/AM(30%) (UC, ES): -15.35 dBs  
 FM/AM(30%) (EW5): -11.35 dBs  
 FRONT AUX IN: +0.86 dBs  
 REAR AUX IN(H): +0.92 dBs  
 REAR AUX IN(L): +0.86 dBs  
 A-EQ: +23.78 dBs

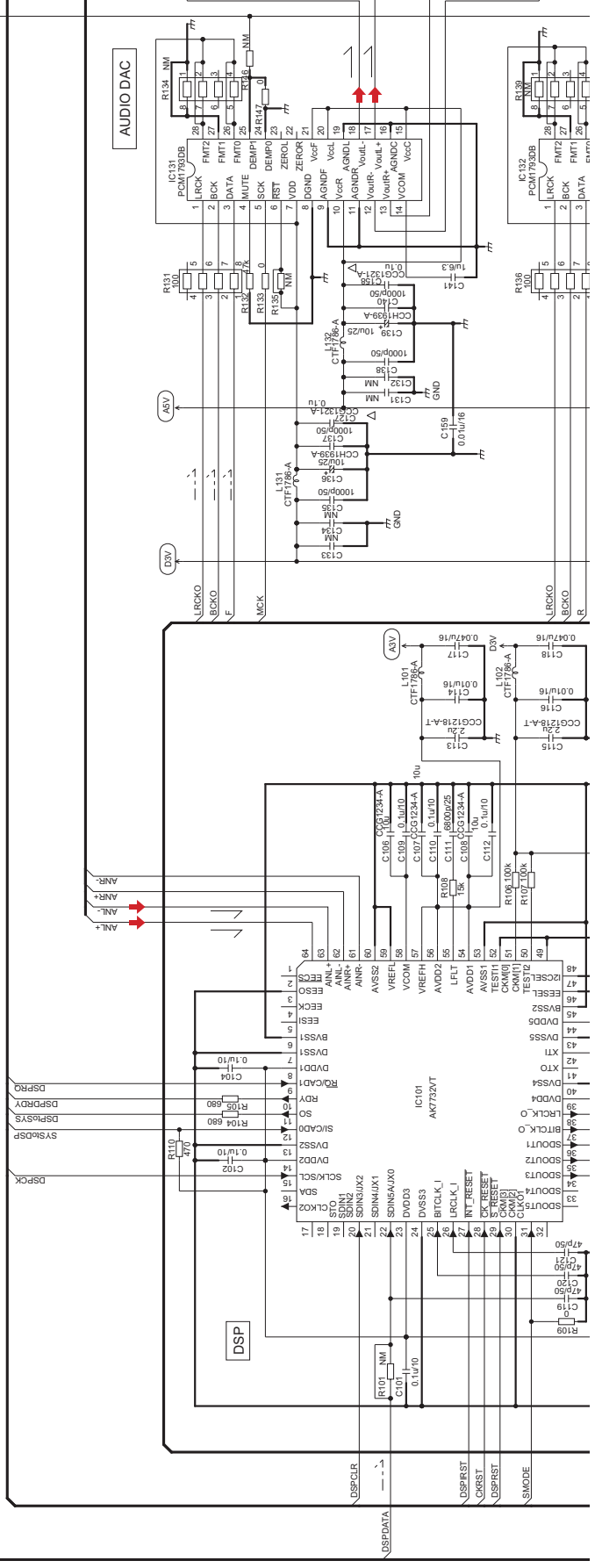

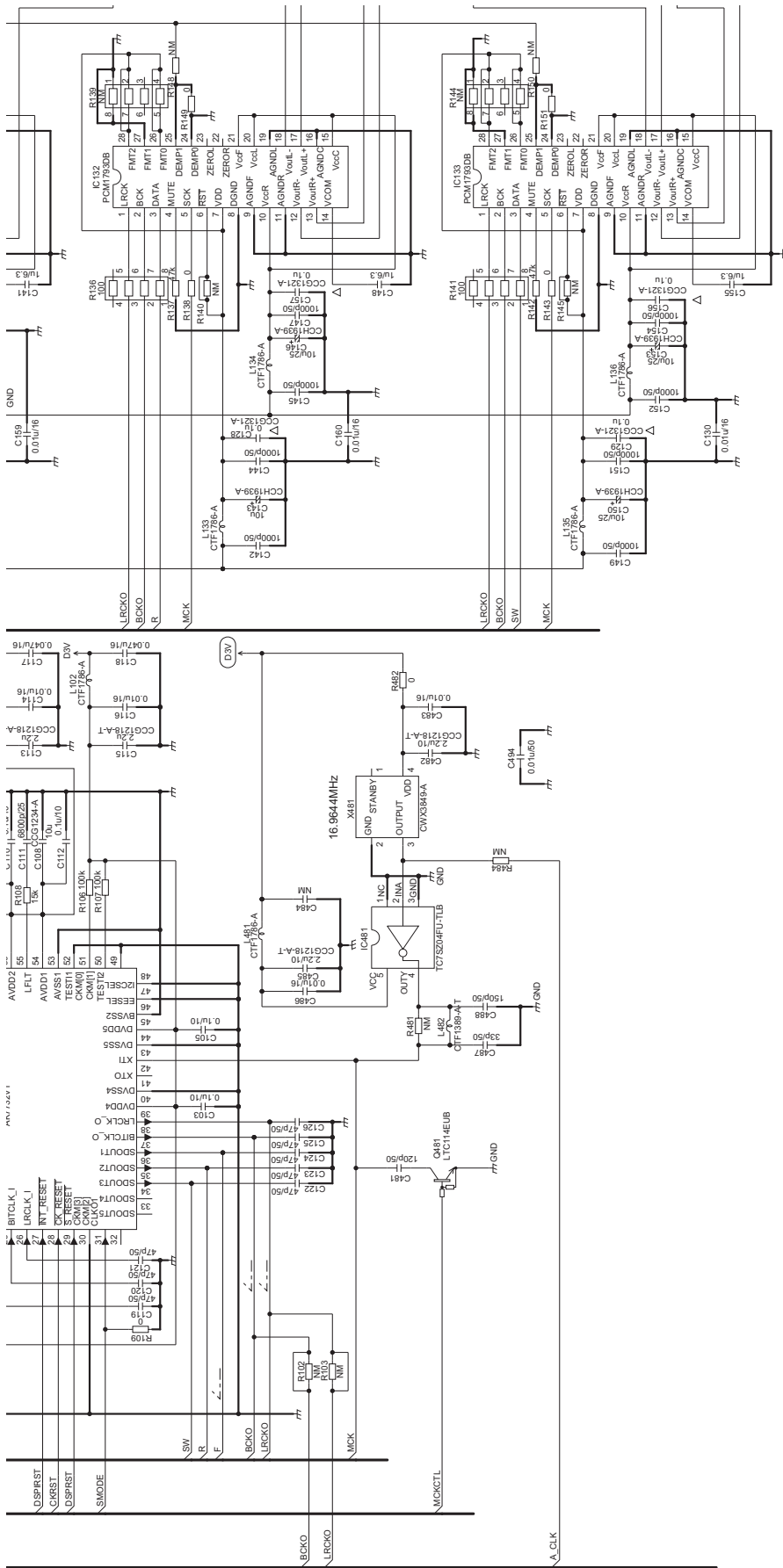

A-b 3/4

A-a A-b

A-a 3/4

# 10.4 TUNER AMP UNIT (POWER SUPPLY BLOCK) (GUIDE PAGE)

A-a 4/4

REFERENCE AREA MAP

591-600	TUN5V
831-850	AUDIO+B
851-930	OTHER+B
941-970	USB5V/HISIDE SW

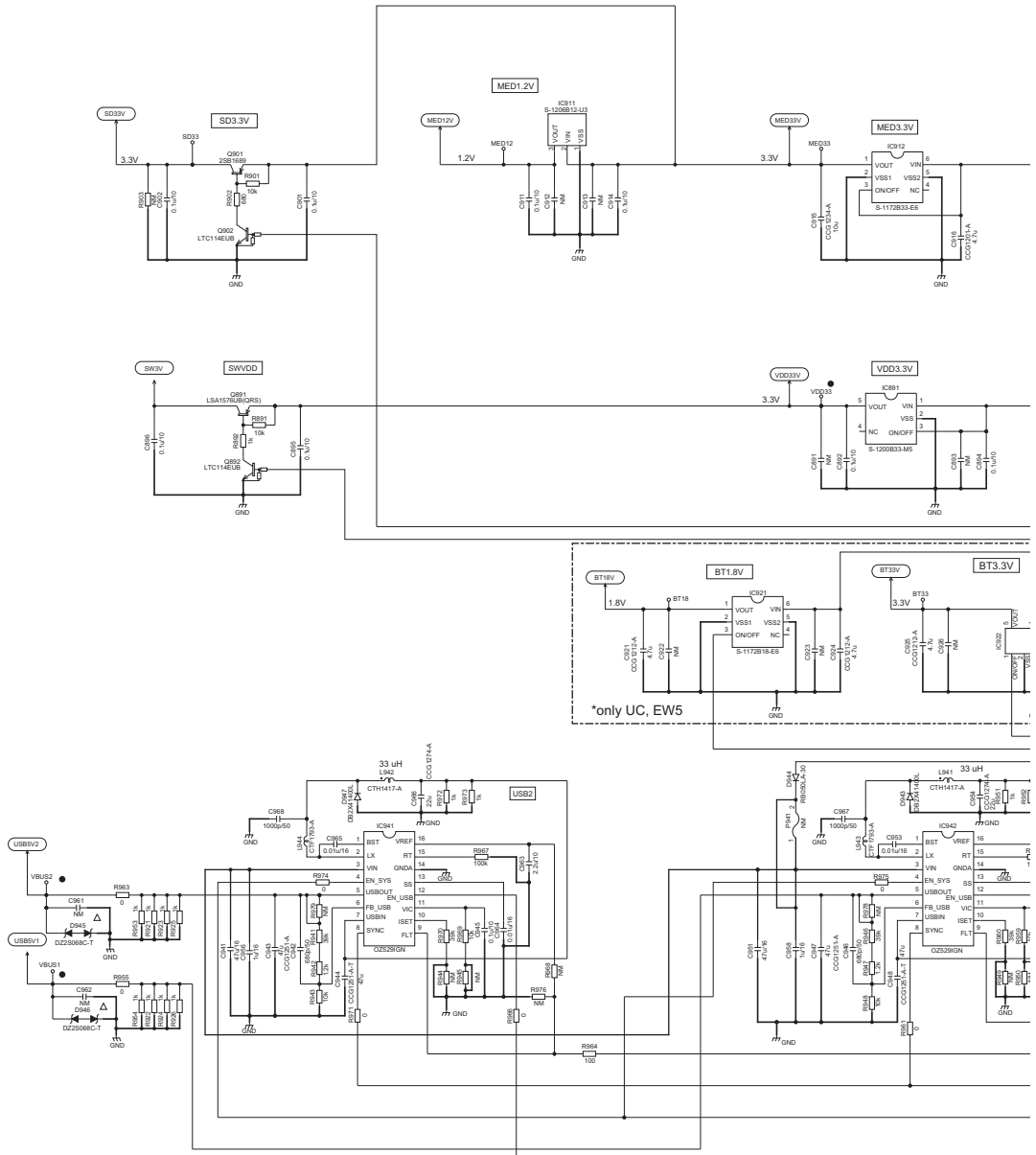

\*only UC, EW5



# A-b 4/4

## A/4 TUNER AMP UNIT (POWER SUPPLY BLOCK)

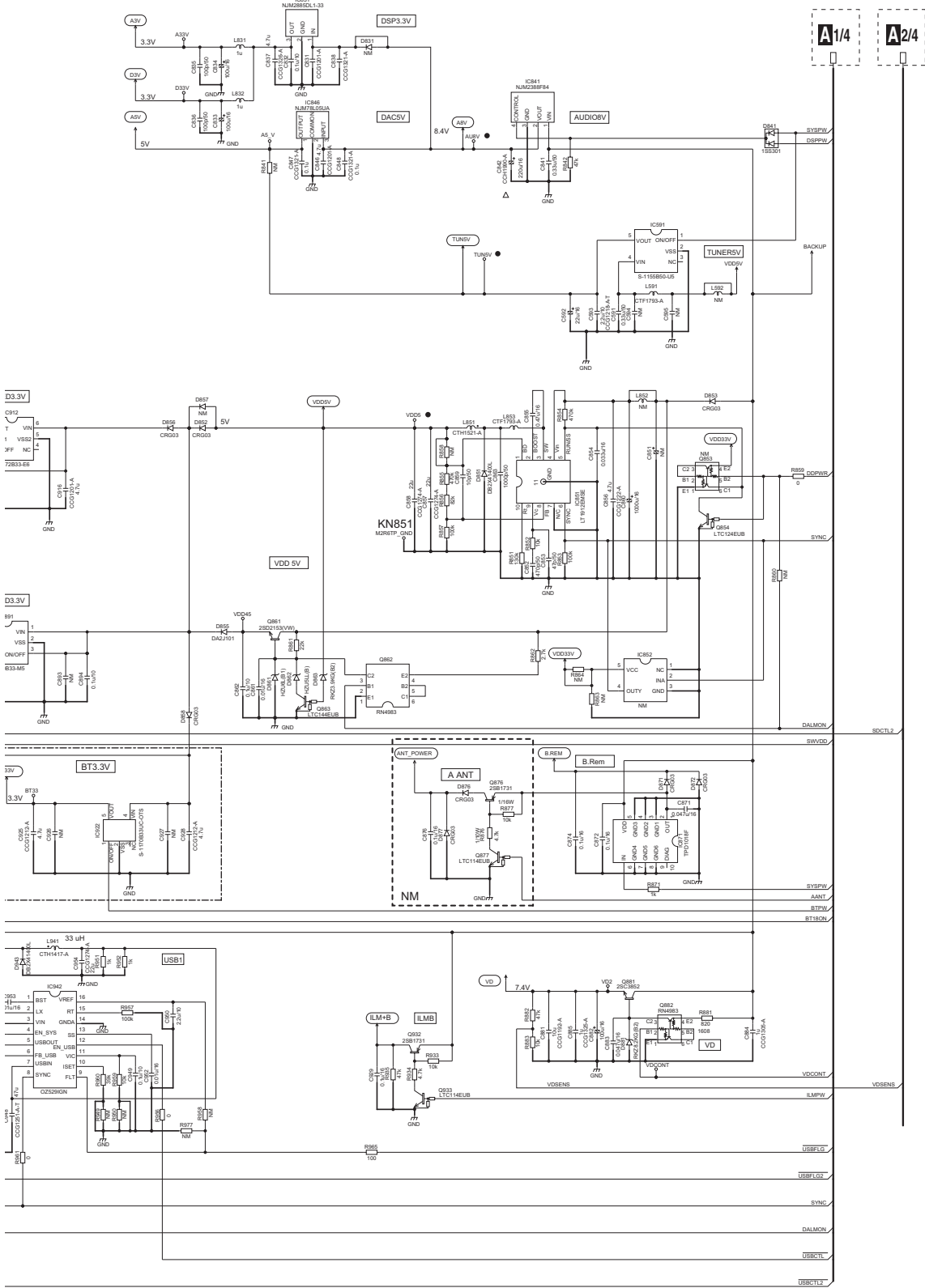

# A4/4 TUNER AMP UNIT (POWER SUPPLY BLOCK)

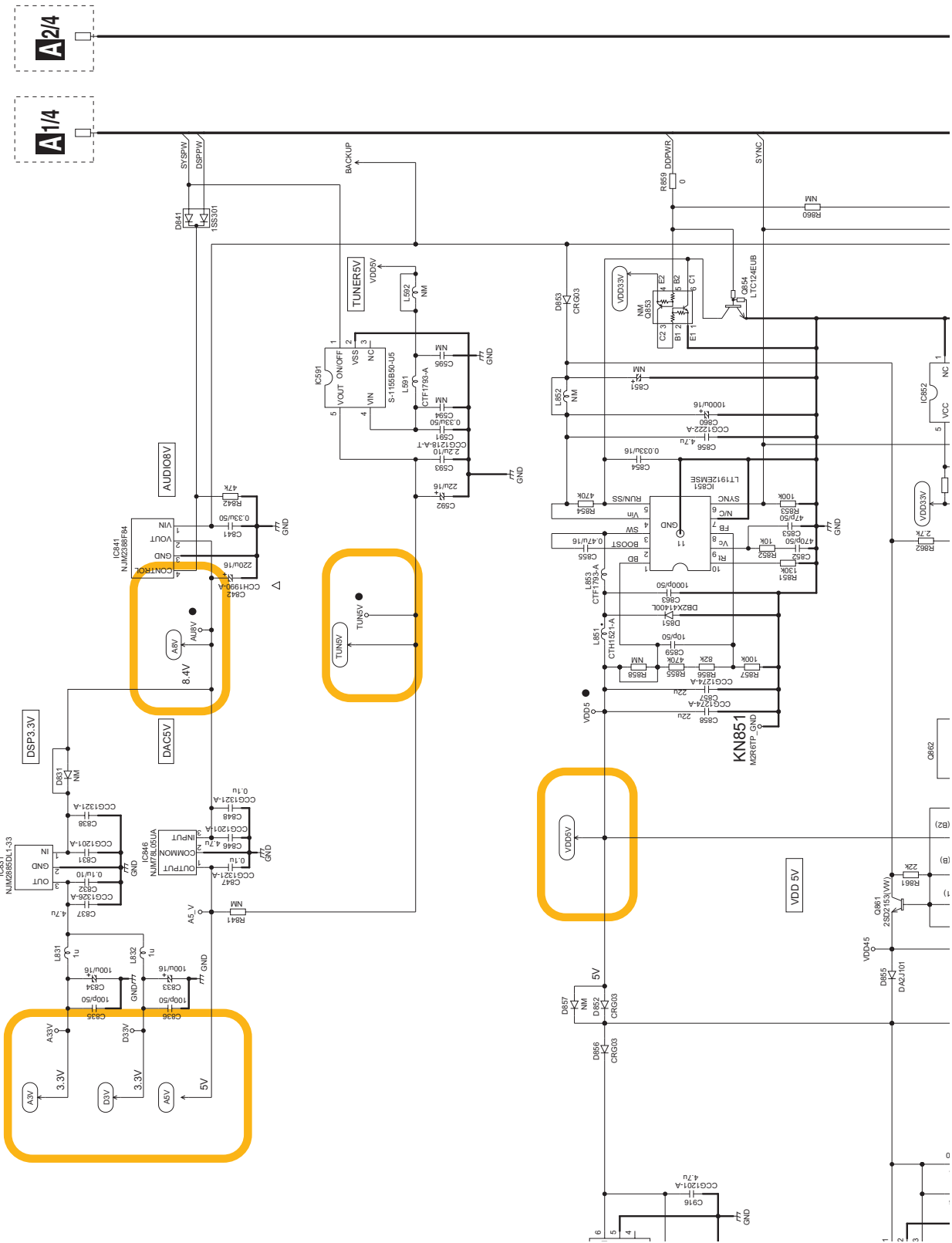

A-a A-b

A-b 4/4

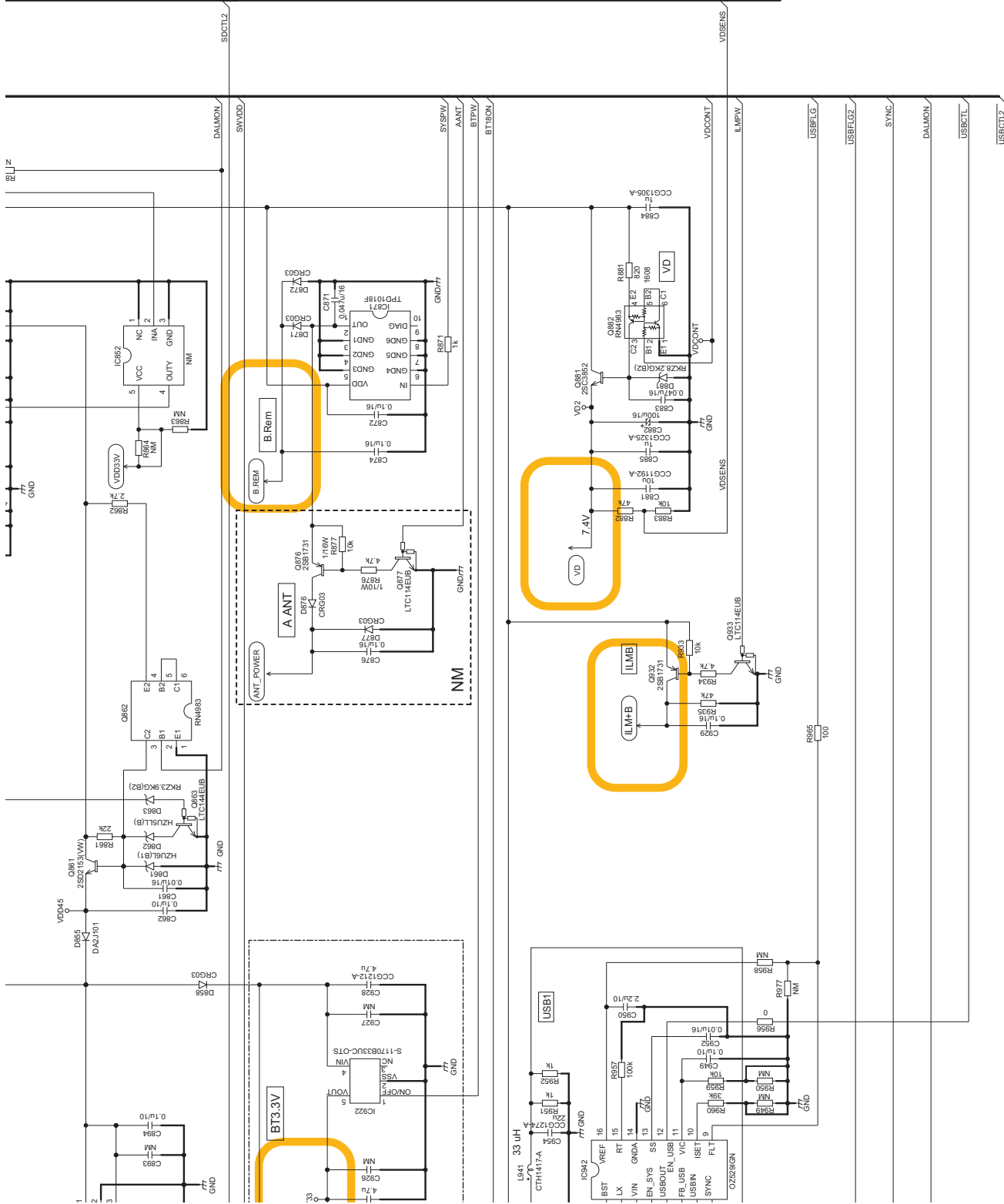

DEH-80PRS/XNUC

A-a A-b

A-b 4/4

1

2

3

4

A-b 4/4

REFERENCE AREA MAP

- 591-600 TUN5V
- 831-850 AUDIO+B
- 851-930 OTHER+B
- 941-970 USB5V/HISIDE SW

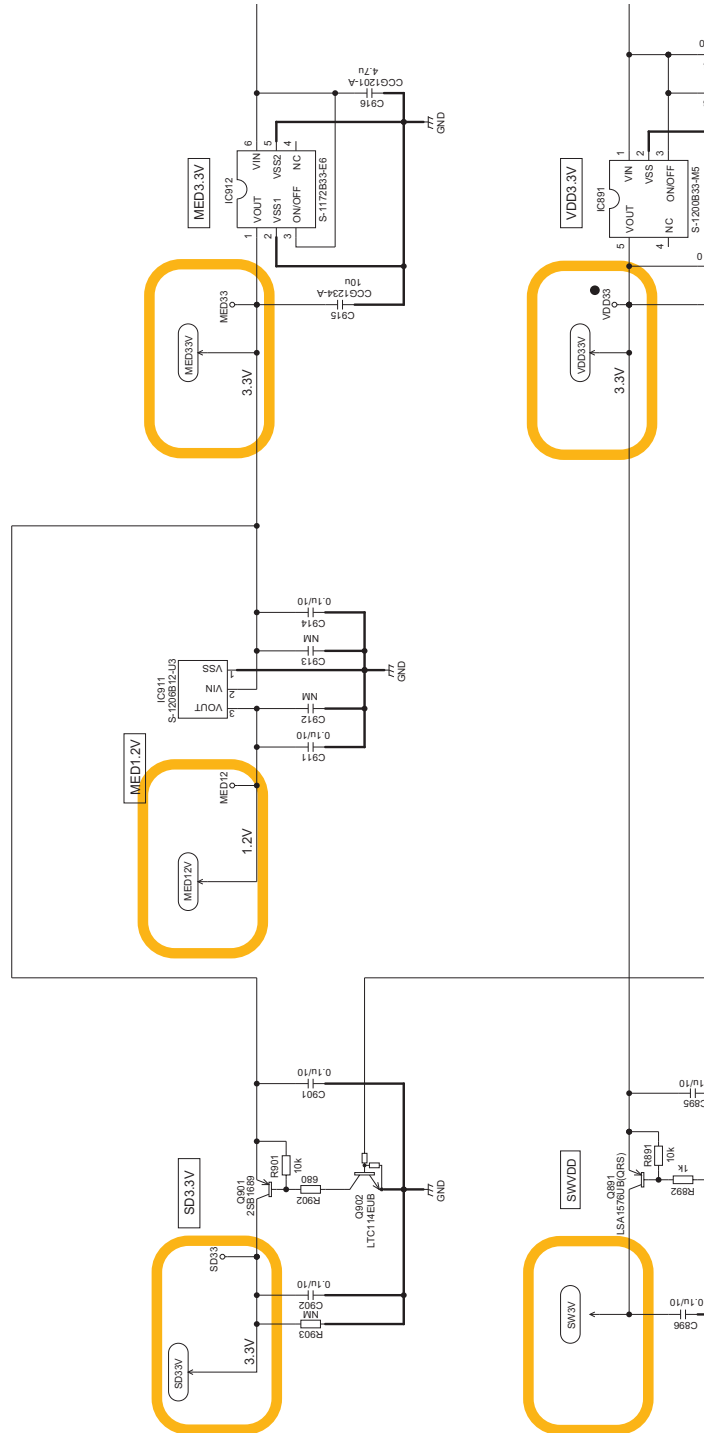

A

B

C

D

E

F

A-a 4/4

1

2

3

4

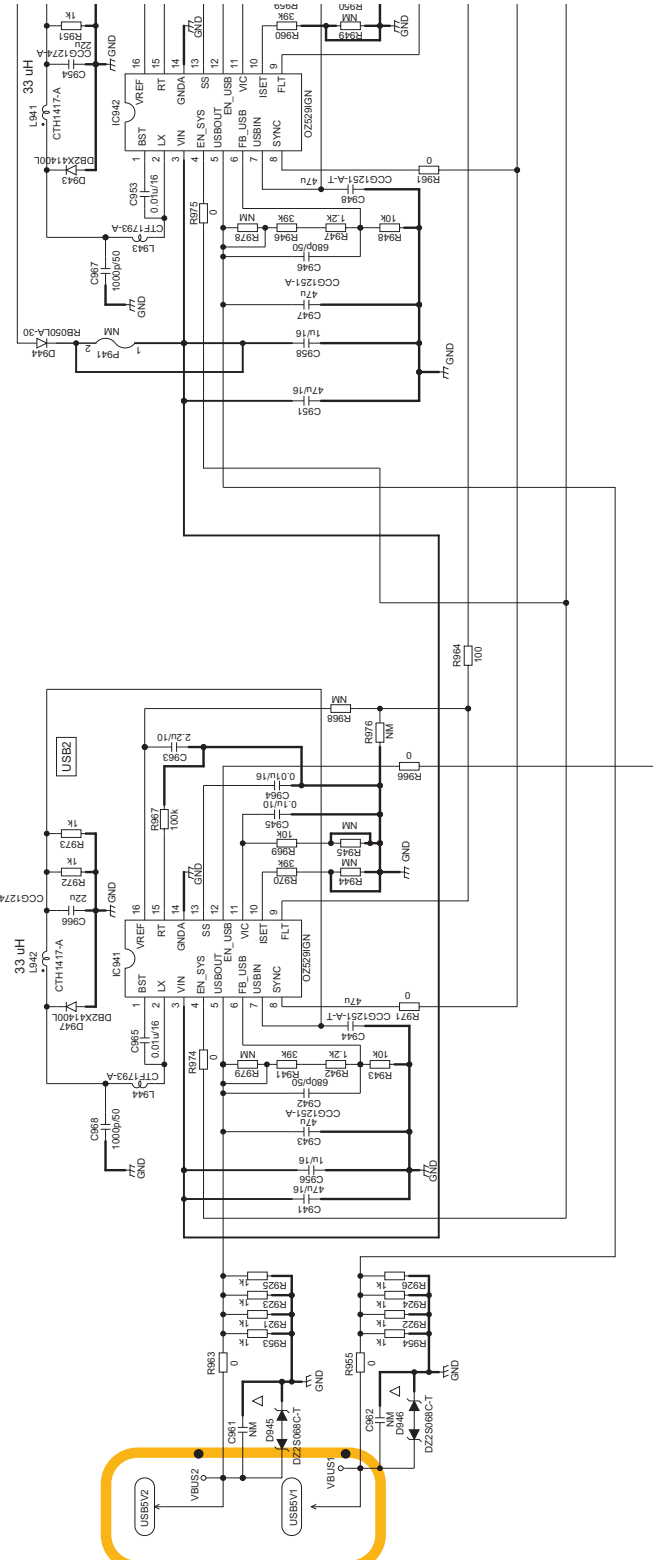
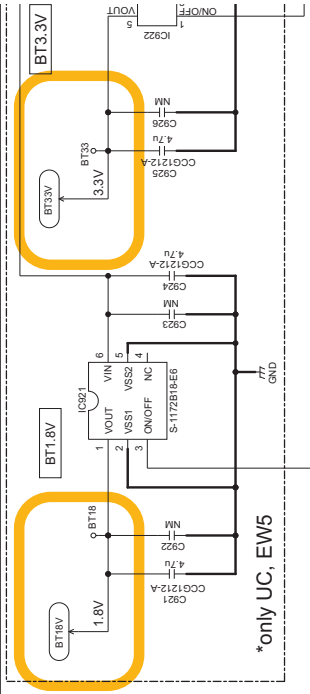
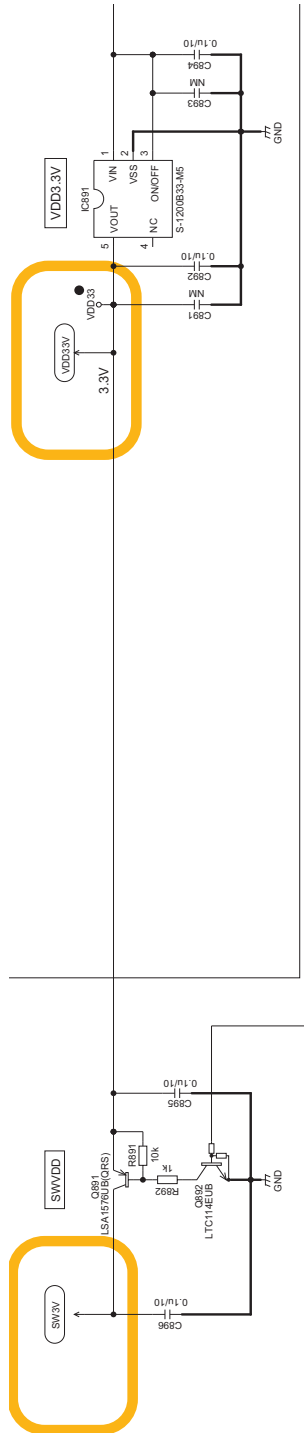

# 10.5 KEYBOARD UNIT

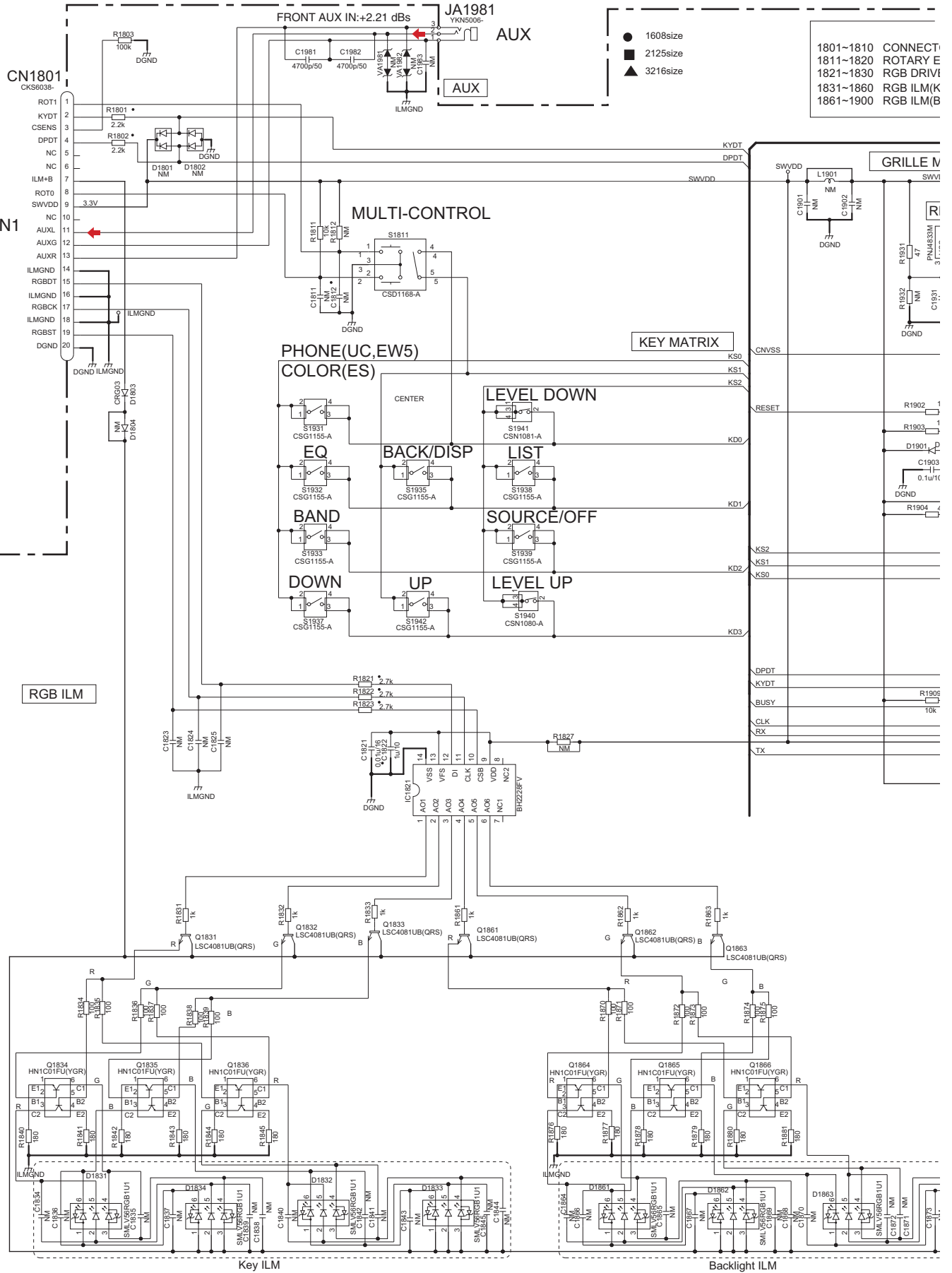

REFERENCE AREA MAP

- 1~1810 CONNECTOR
- 1~1820 ROTARY ENCODER
- 1~1830 RGB DRIVER
- 1~1860 RGB ILM(KEY)
- 1~1900 RGB ILM(B.LIGHT)
- 1901~1930 GRILLE MICRO & ROM
- 1931~1940 REMOTE&KEY
- 1941~1950 ROM CORRECTION
- 1951~1980 LCD
- 1981~1990 AUX

B KEYBOARD UNIT

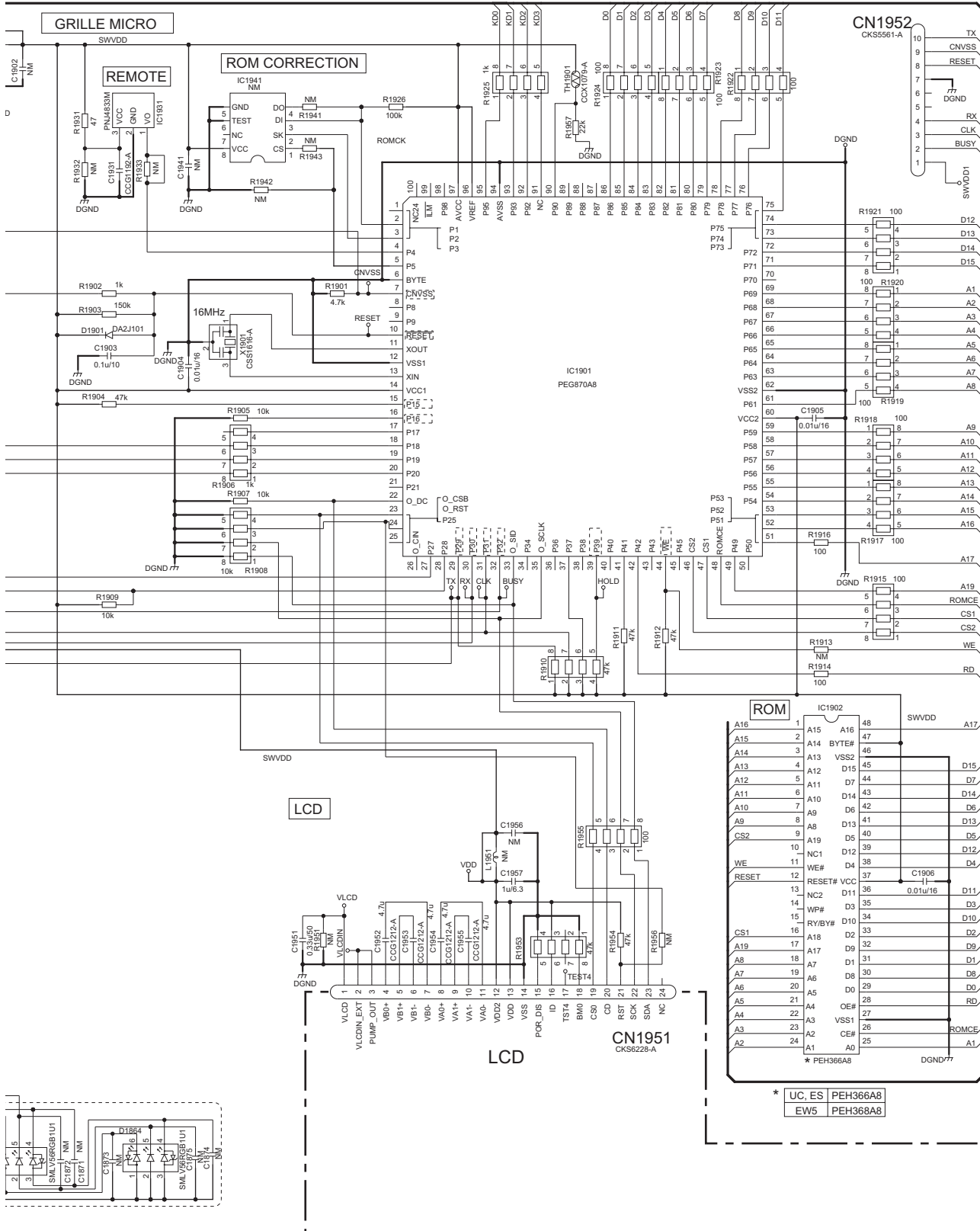

# 10.6 CD CORE UNIT (S11.6STD)

## PICK UP UNIT(P10.6) (SERVICE)

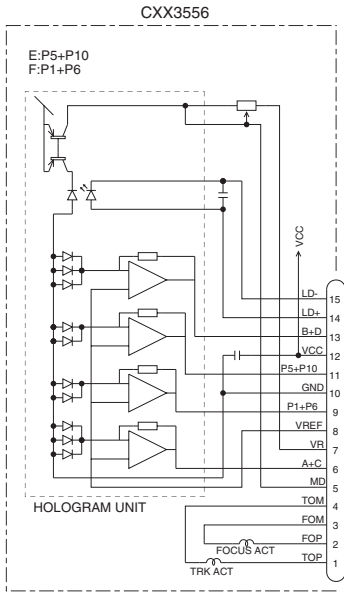

F.ACT: Applying positive voltage to FOP, the lens approaches DISC.  
 T.ACT: Applying positive voltage to TOP, the lens moves outer circumference of DISC.

• NO MOUNT PARTS (NM)

□ Land for manual soldering

M1 SPDL MOTOR  
CXE2273

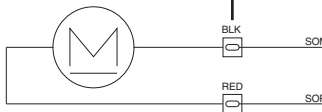

M2 LOAD/CRG MOTOR  
CXC4026



HOME

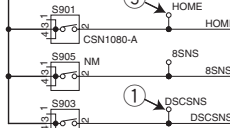

DSCSNS

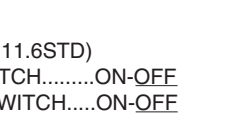

SWITCHES:  
 CD CORE UNIT (S11.6STD)  
 S901:HOME SWITCH.....ON-OFF  
 S903:DSCSNS SWITCH.....ON-OFF

The underlined indicates the switch position.

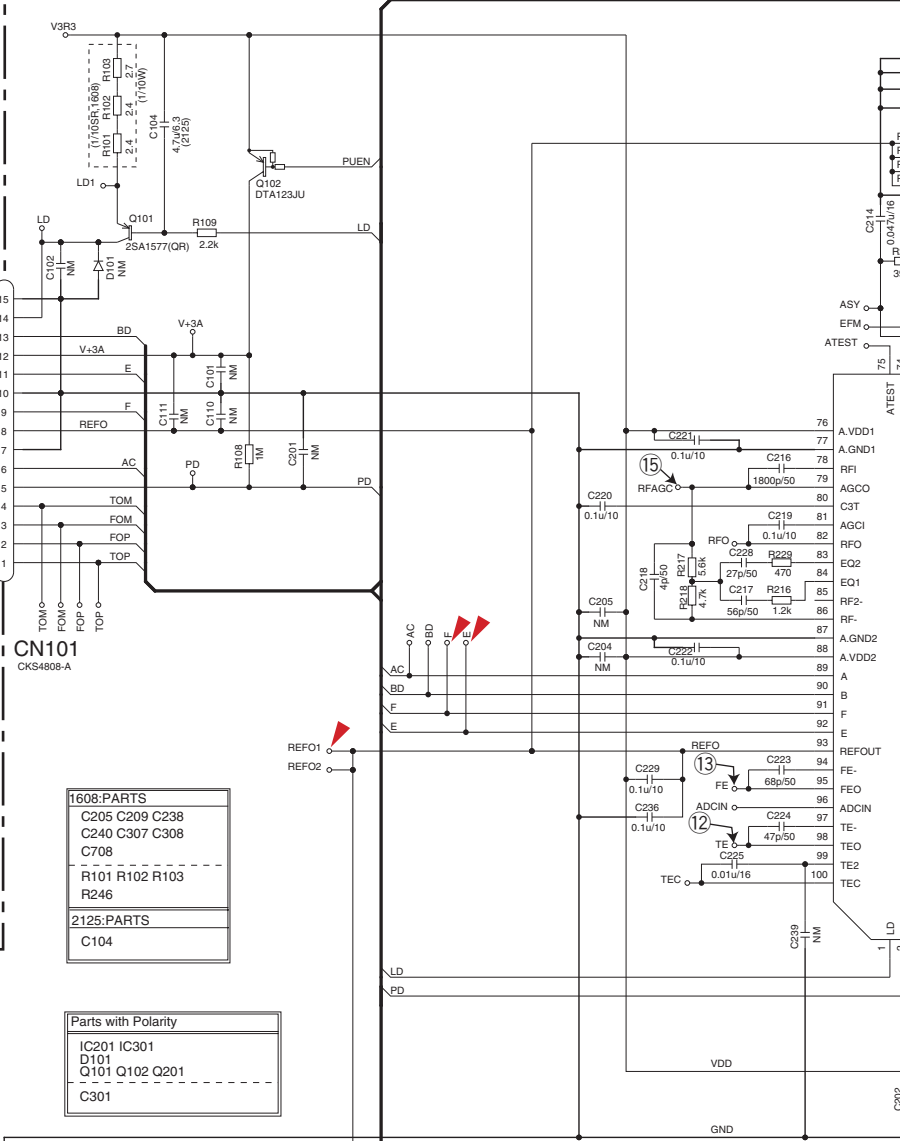

1608:PARTS

C205 C209 C238  
 C240 C307 C308  
 C708

R101 R102 R103  
 R246

2125:PARTS  
 C104

Parts with Polarity

IC201 IC301  
 D101  
 Q101 Q102 Q201  
 C301

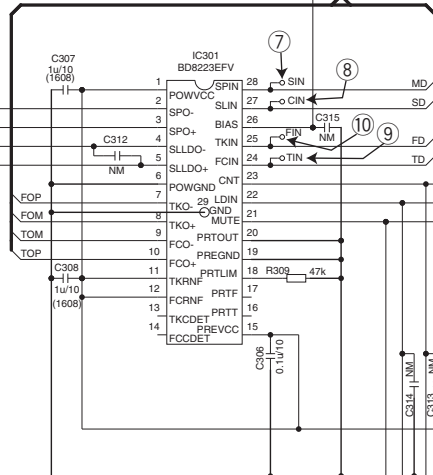

MOTOR DRIVER LOGIC TABLE

	LOAD	EJ	PLAY	OFF
CLCONT	H	H	L	L
LOEJ	H	L	L	L
CONT	L	L	H	L



# C CD CORE UNIT (S11.6STD)

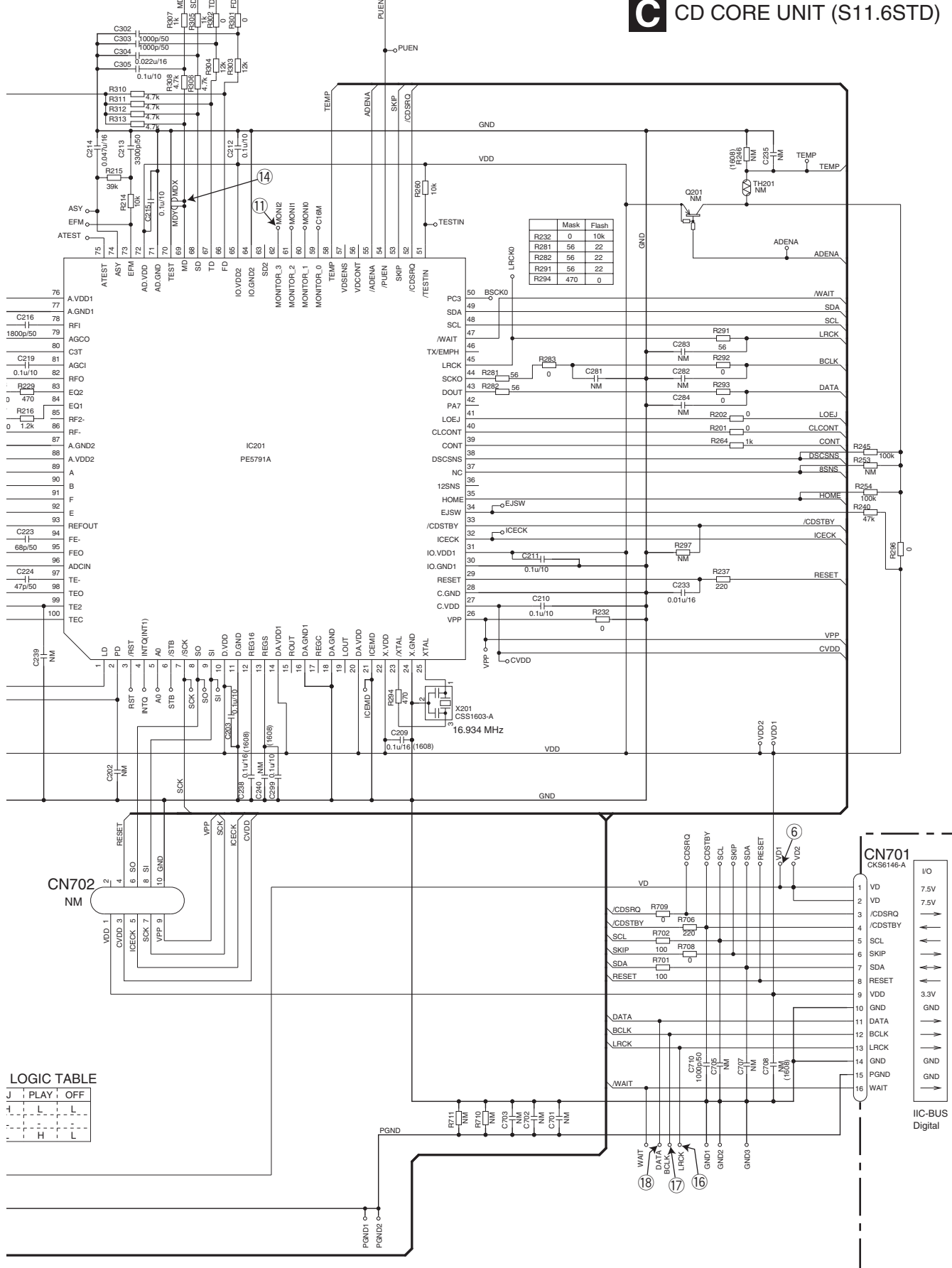

	Mask	Flesh
R222	0	10k
R281	56	22
R282	56	22
R291	56	22
R294	470	0

**LOGIC TABLE**

J	PLAY	OFF
L	L	L
L	L	L
H	L	L

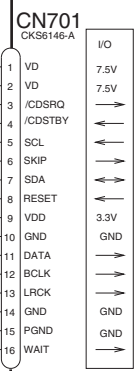

**A2/4**  
CN461

# 10.7 PANEL UNIT

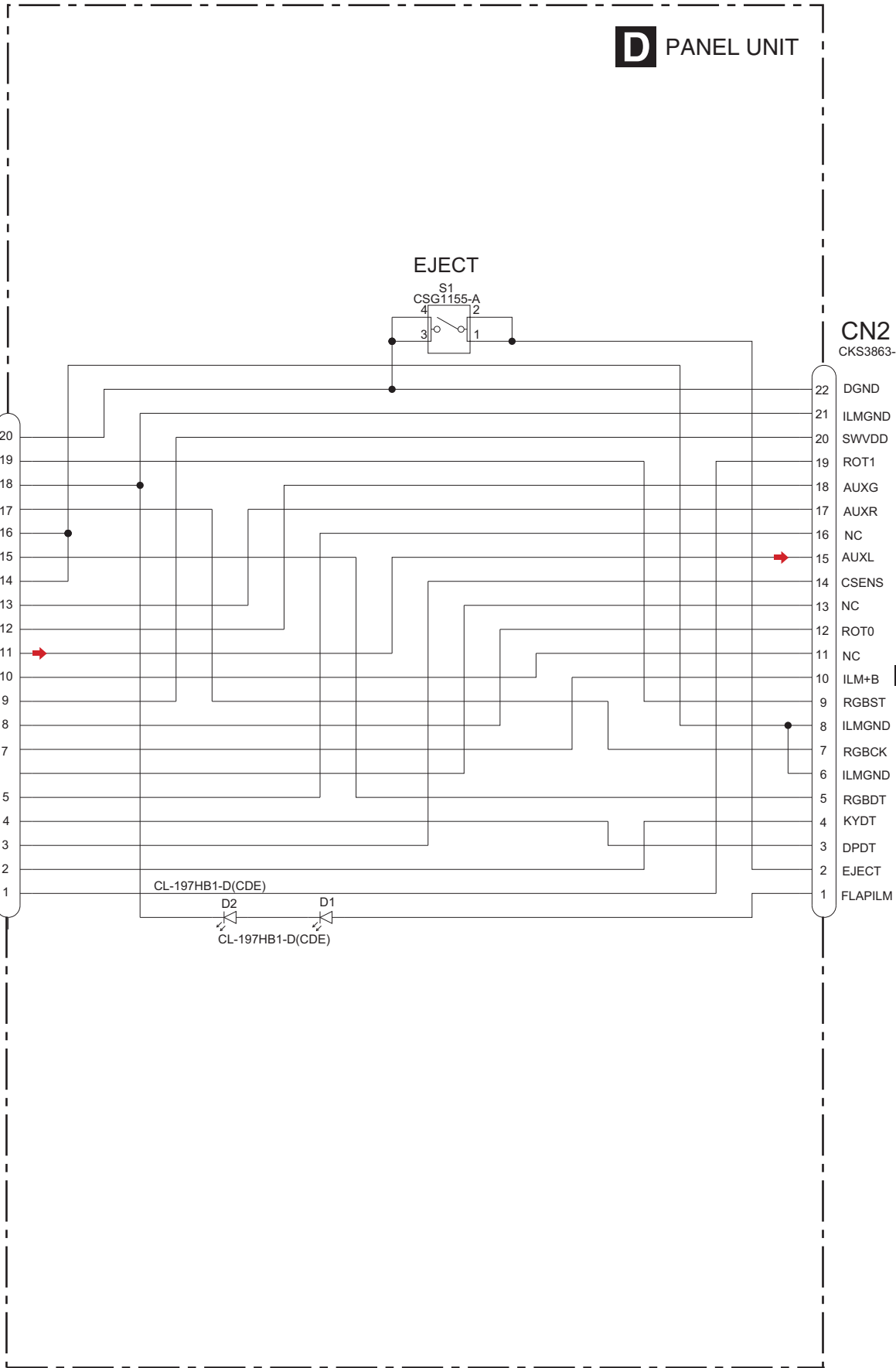

**D**

# 10.8 WAVEFORMS

## ● CD CORE UNIT(S11.6STD)

Note : 1. The encircled numbers denote measuring points in the circuit diagram.  
 2. Reference voltage REFO1(1.65 V)

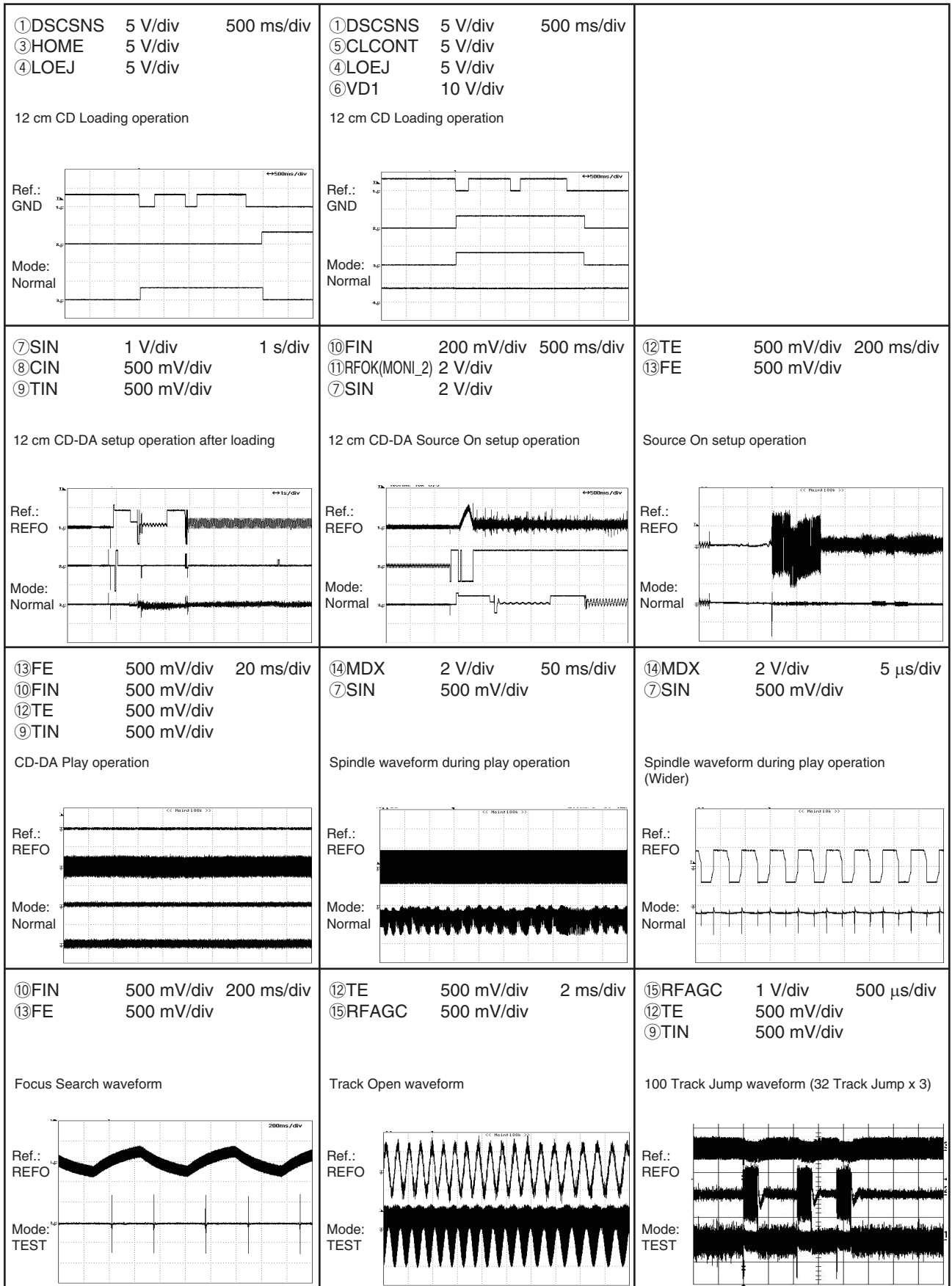

A

⑮RFAGC 1 V/div 2 ms/div  
 ⑫TE 500 mV/div  
 ⑨TIN 500 mV/div

32 Tracks Jump waveform  
 (Zoom of 100 Track Jump waveform)

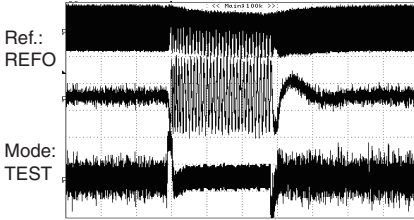

⑮RFAGC 1 V/div 200 ms/div  
 ⑫TE 1 V/div  
 ⑧CIN 500 mV/div  
 ⑦SIN 2 V/div

Search operation(Outer to Inner)

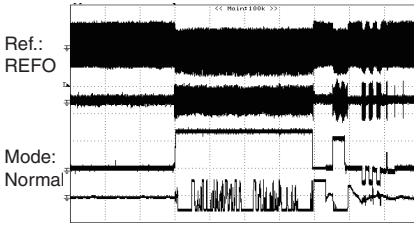

⑯LRCK 2 V/div 10 us/div  
 ⑰BCLK 2 V/div  
 ⑱DOUT(DATA) 2 V/div

Digital Out waveform

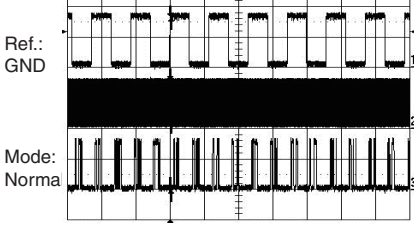

B

①DSCSNS 5 V/div 500 ms/div  
 ⑤CLCONT 5 V/div  
 ④LOEJ 5 V/div

12 cm CD Eject operation

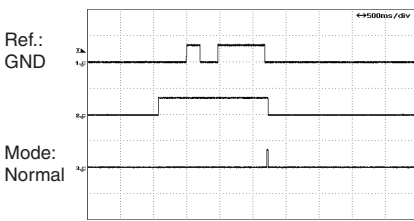

①DSCSNS 5 V/div 500 ms/div  
 ③HOME 5 V/div  
 ④LOEJ 5 V/div

12 cm CD Eject operation

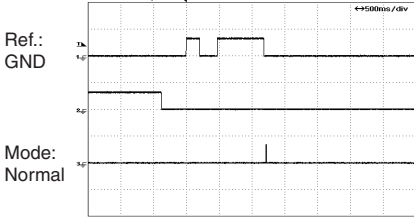

C

⑮RFAGC 1 V/div 500 μs/div  
 ⑨TIN 1 V/div  
 ⑫TE 1 V/div  
 ⑩FIN 1 V/div

Black Dot (800 μm) during play

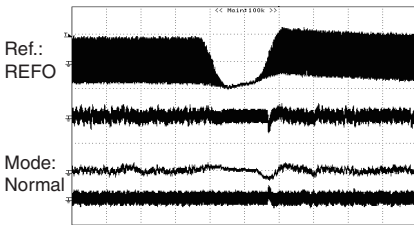

D

E

F

A

B

C

D

E

F

# 11. PCB CONNECTION DIAGRAM

## 11.1 TUNER AMP UNIT

### A NOTE FOR PCB DIAGRAMS

1. The parts mounted on this PCB include all necessary parts for several destination. For further information for respective destinations, be sure to check with the schematic diagram.

2. Viewpoint of PCB diagrams

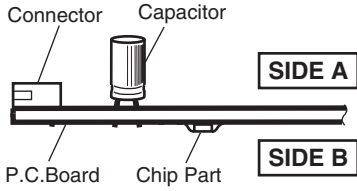

### A TUNER AMP UNIT

B

C

D

E

F

BT MODULE ←

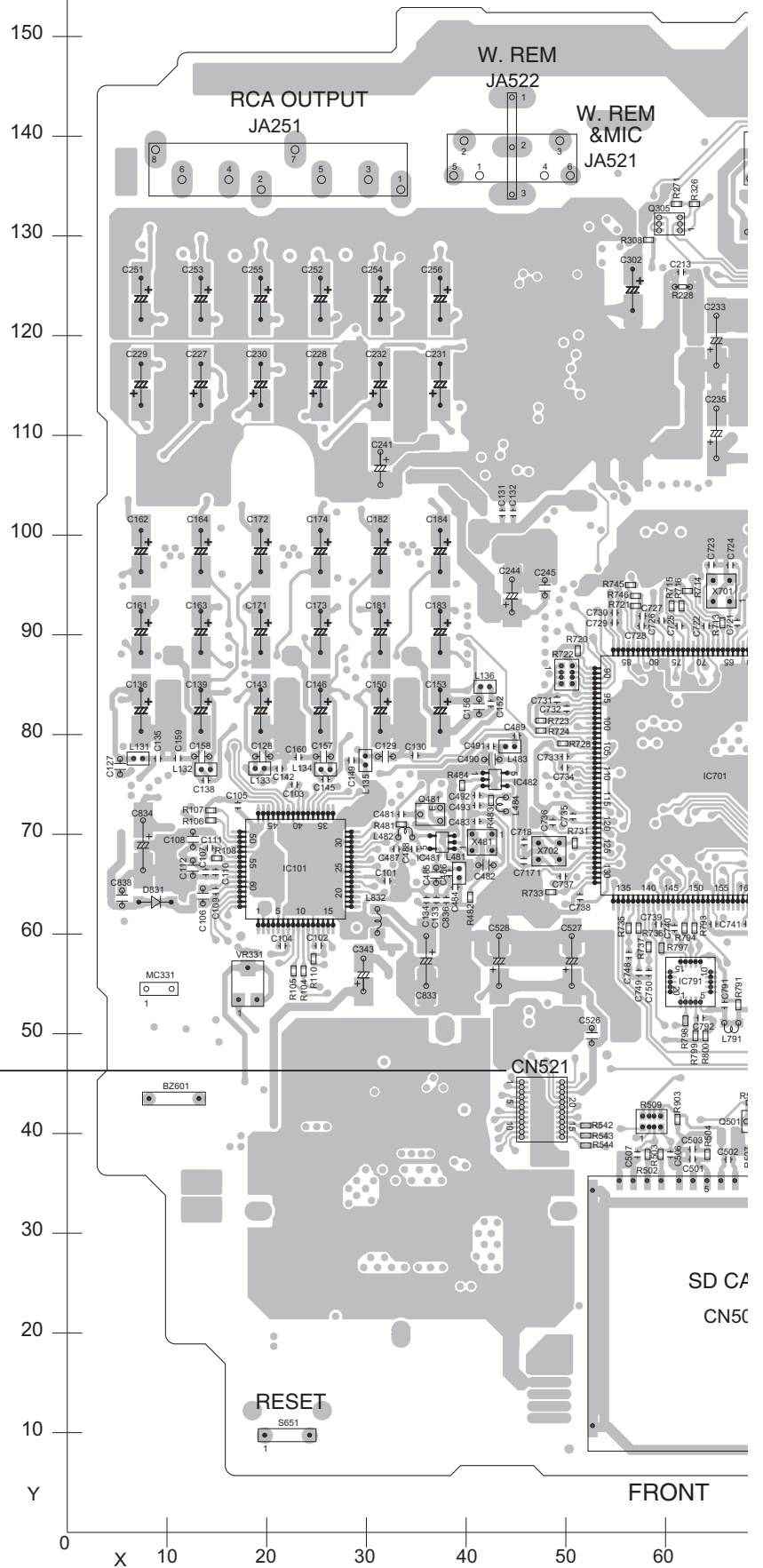

SD CA  
CN50

FRONT

A

SIDE A

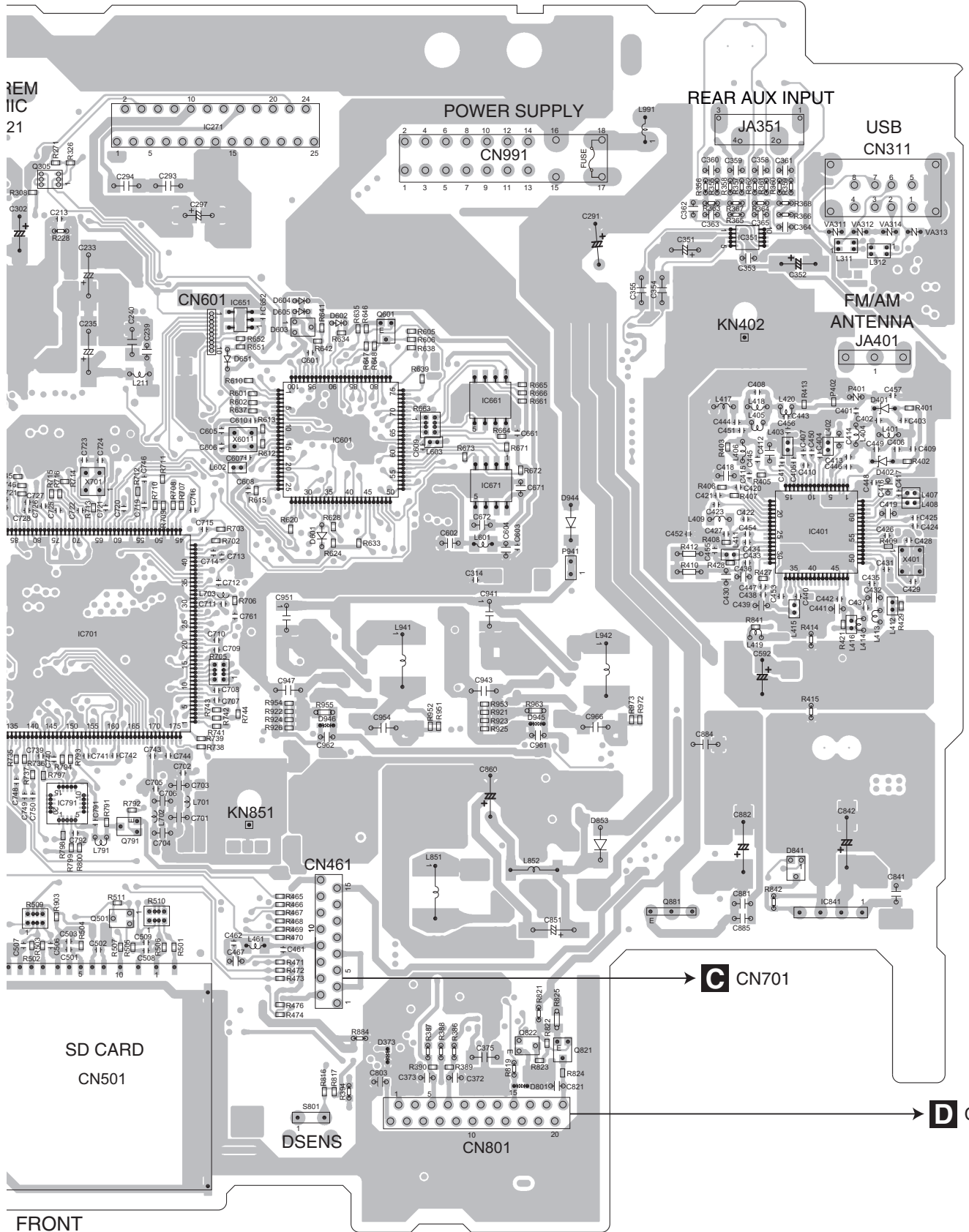

REM IIC 21

POWER SUPPLY

REAR AUX INPUT

USB CN311

CN601

KN402

FM/AM ANTENNA JA401

KN851

CN461

SD CARD CN501

DSENS S801

CN801

C CN701

D CN2

FRONT

60 70 80 90 100 110 120 130 140 150 160 170

DEH-80PRS/XNUC

A

# A TUNER AMP UNIT

A

B

C

D

E

F

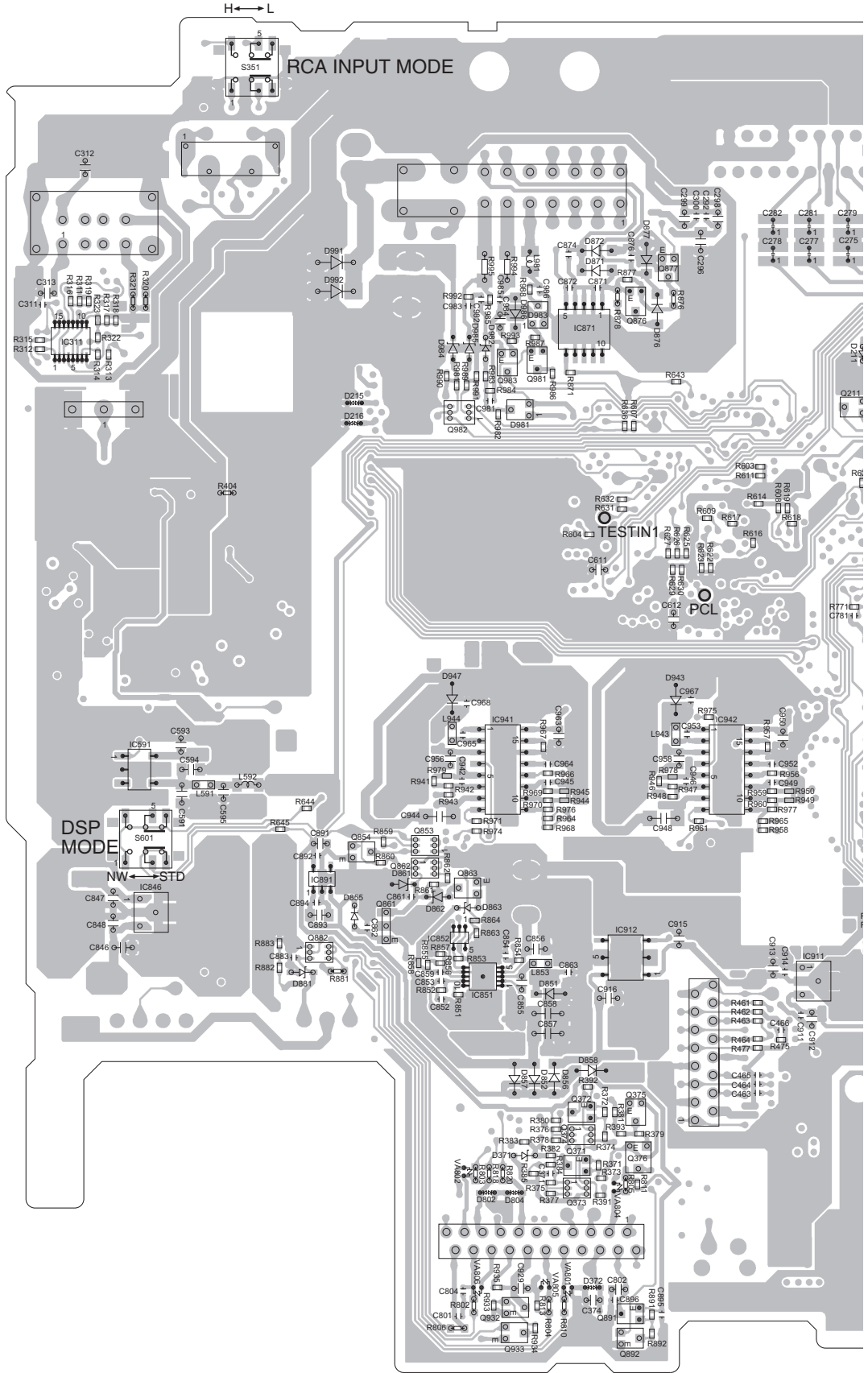

170 160 150 140 130 120 110 100 90 80



SIDE B

A  
B  
C  
D  
E  
F

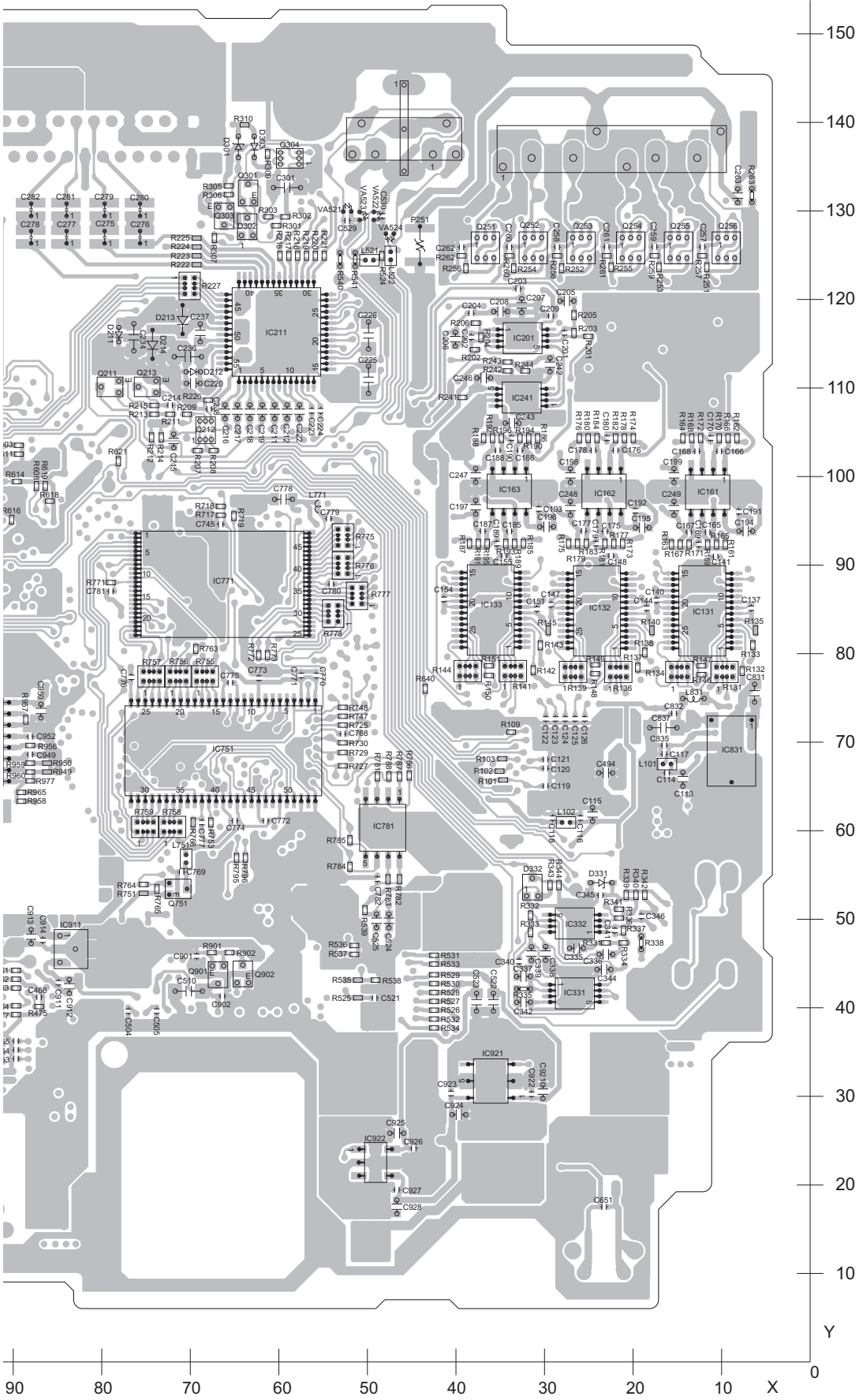

DEH-80PRS/XNUC

A

# 11.2 KEYBOARD UNIT

## B KEYBOARD UNIT

SIDE A

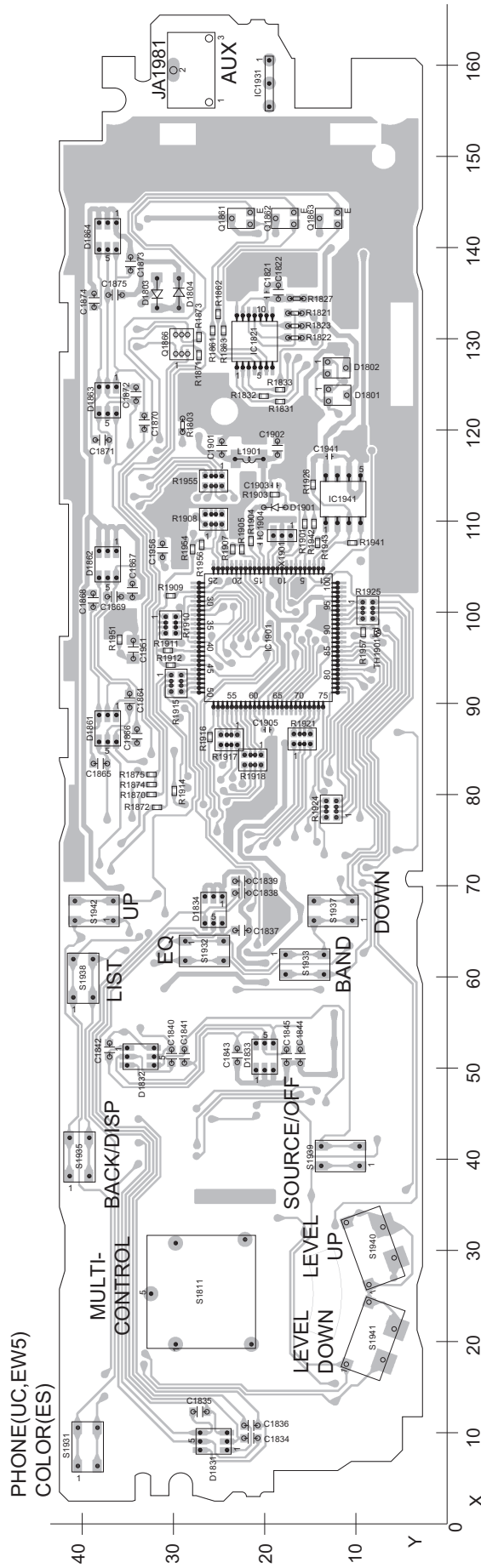

# B KEYBOARD UNIT

SIDE B

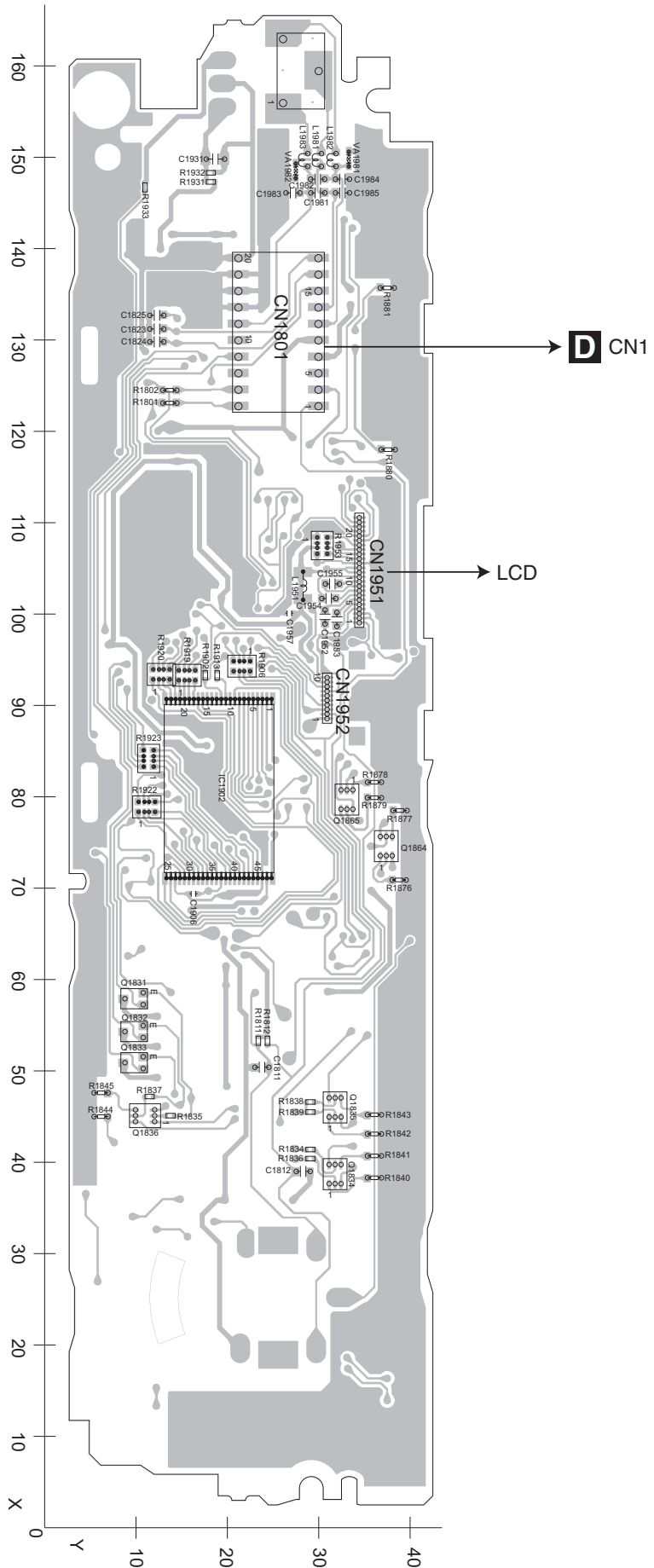

DEH-80PRS/XNUC

B

# 11.3 CD CORE UNIT (S11.6STD)

**C** CD CORE UNIT (S11.6STD)

**SIDE A**

A

PICK UP UNIT(P10.6) (SERVICE)

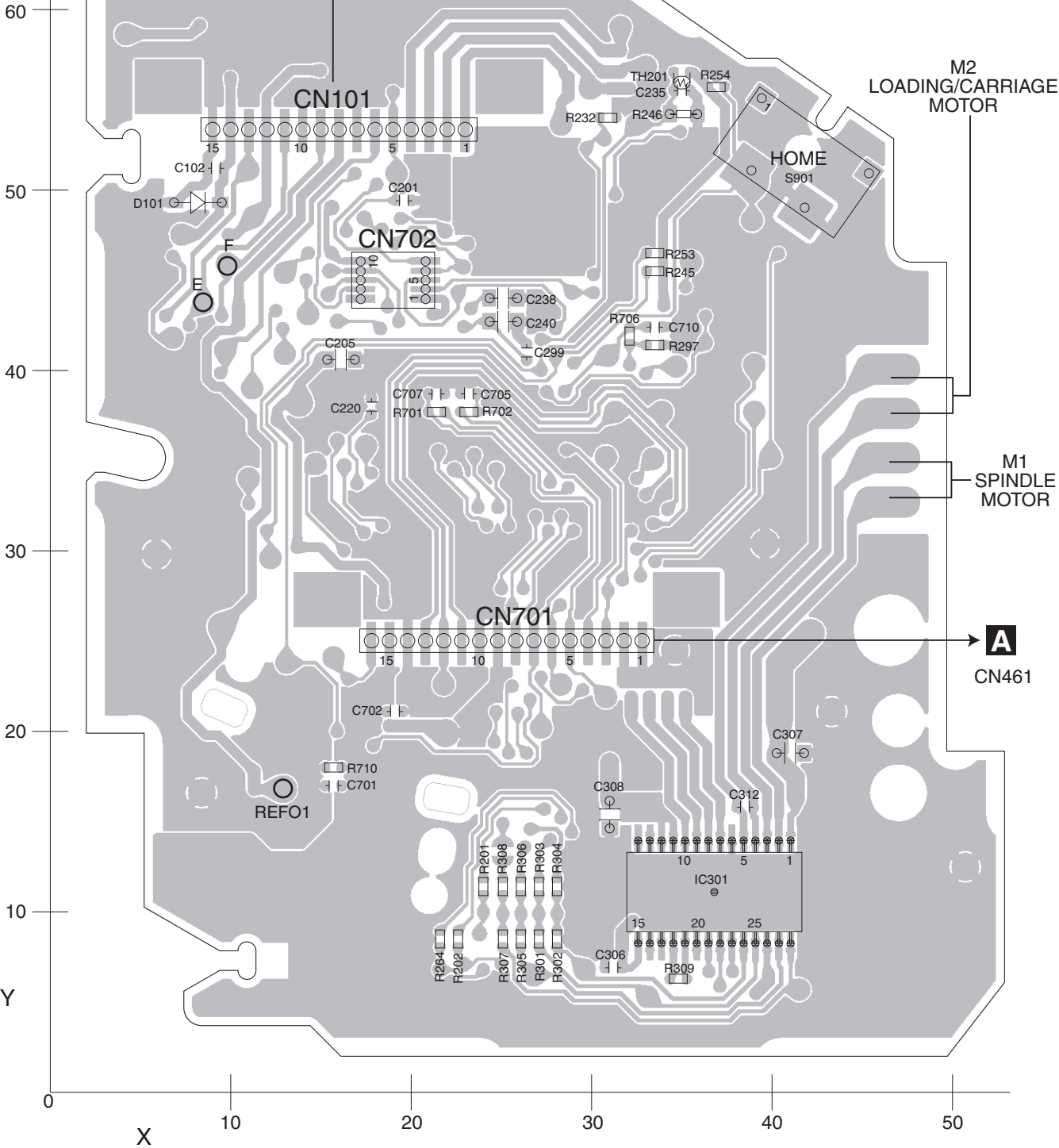

**C**

DEH-80PRS/XNUC

**C** CD CORE UNIT (S11.6STD)

**SIDE B**

A

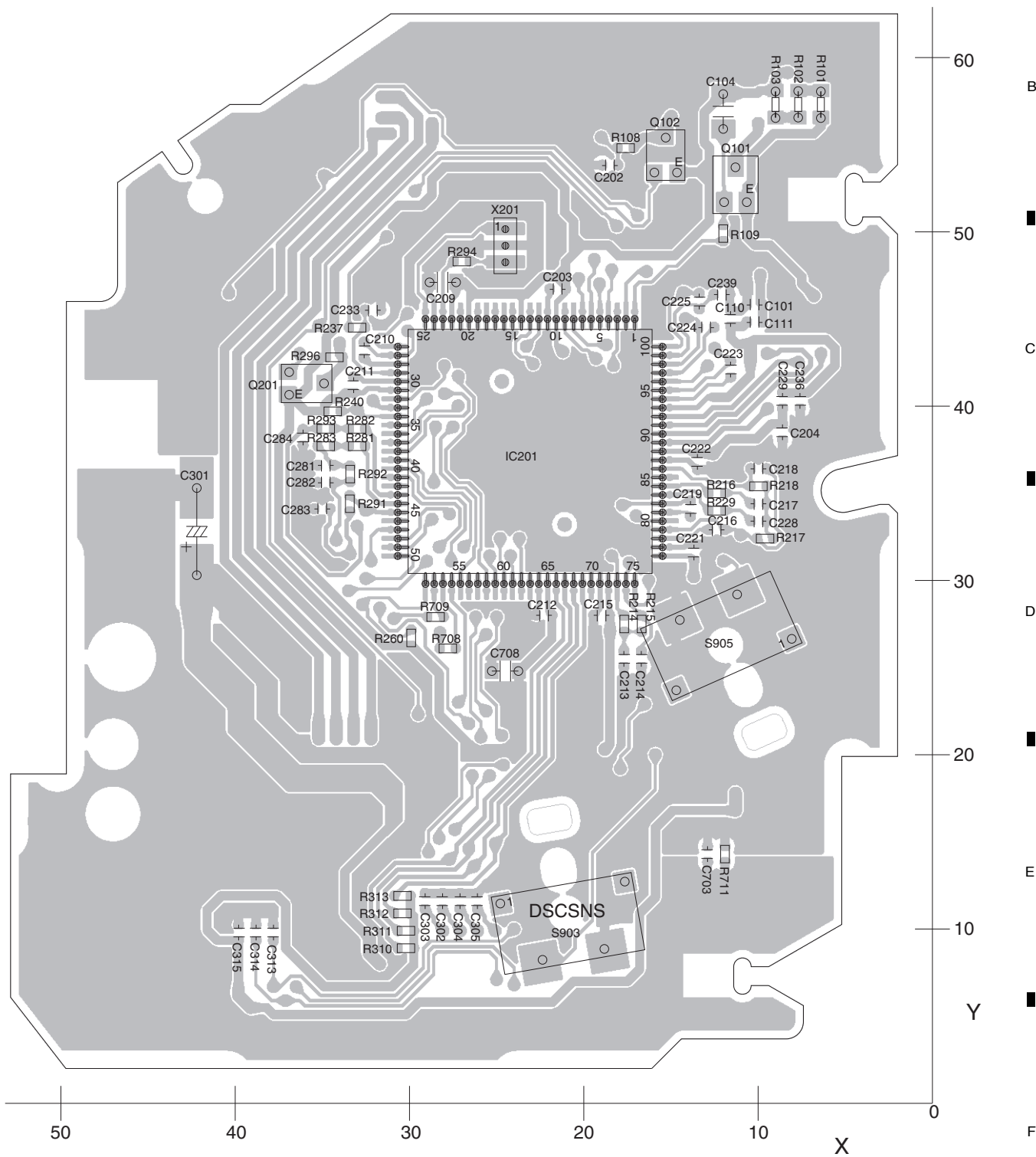

# 11.4 PANEL UNIT

**D** PANEL UNIT

**SIDE A**

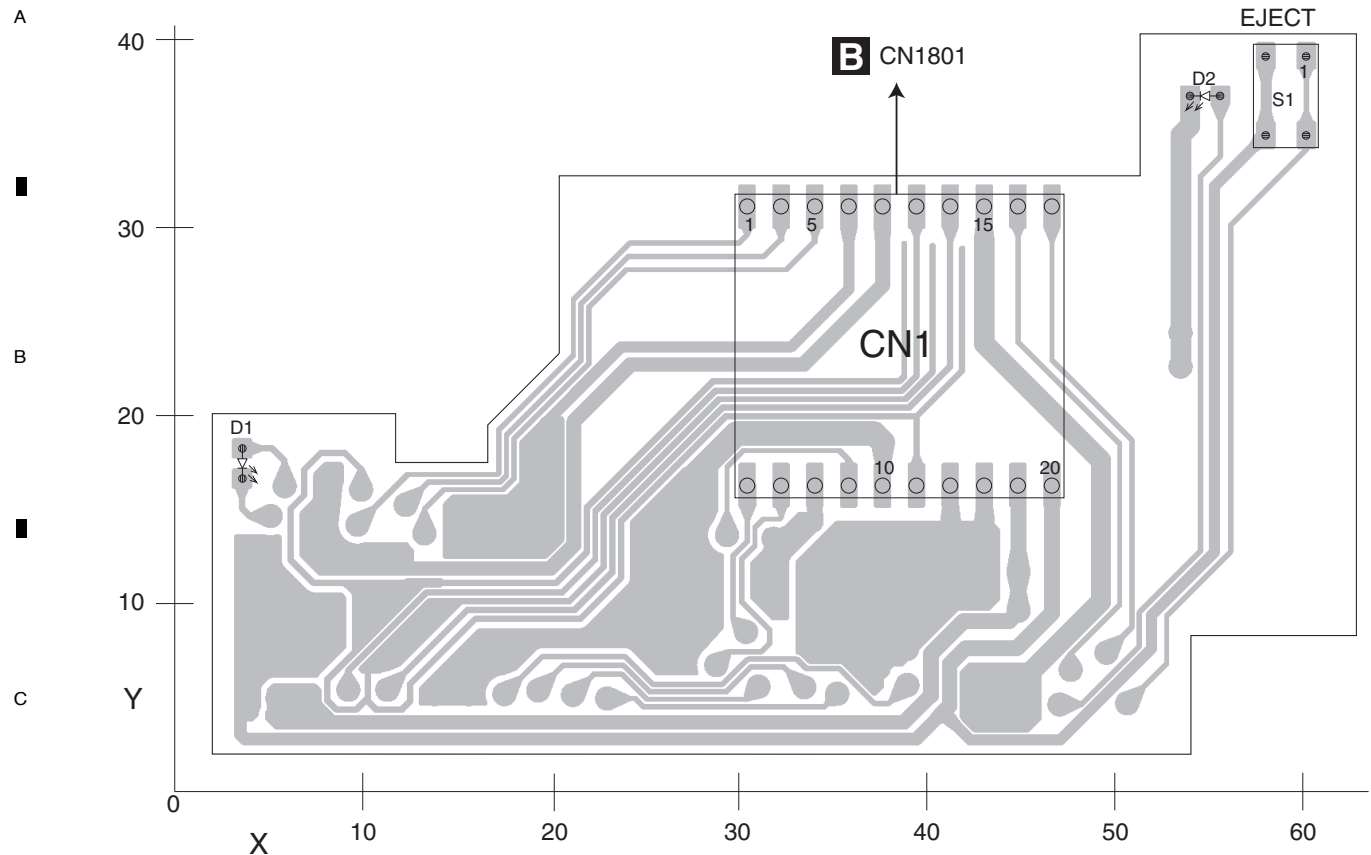

**D** PANEL UNIT

**SIDE B**

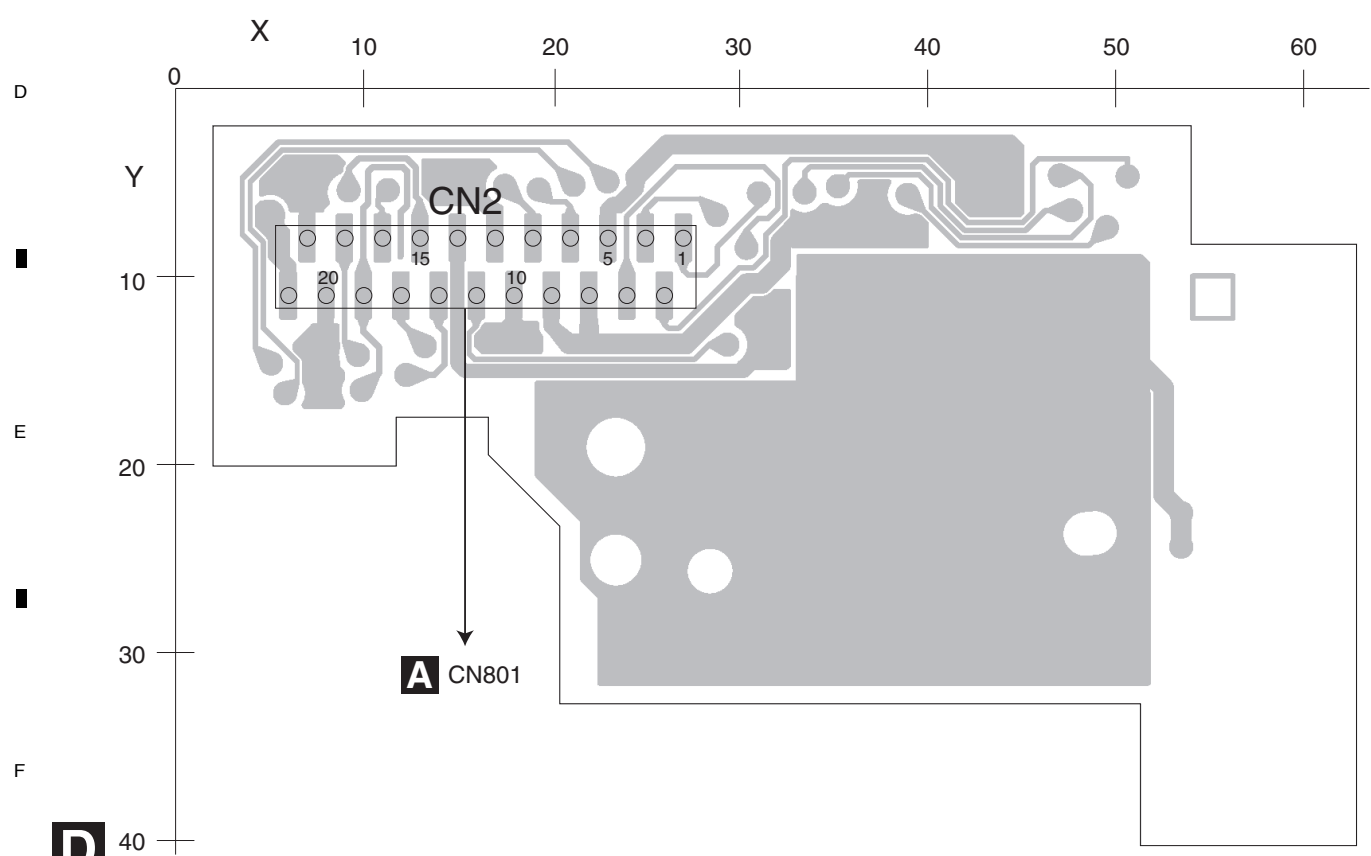

# 12. ELECTRICAL PARTS LIST

**NOTE:**

- Parts whose parts numbers are omitted are subject to being not supplied.
- The part numbers shown below indicate chip components.

Chip Resistor

RS1/○S○○○○J,RS1/○○S○○○○J

Chip Capacitor (except for CQS.....)

CKS....., CCS....., CSZS.....

- The  $\triangle$  mark found on some component parts indicates the importance of the safety factor of the part. Therefore, when replacing, be sure to use parts of identical designation.
- Meaning of the figures and others in the parentheses in the parts list.

Example) IC 301 is on the point (face A, 91 of x-axis, and 111 of y-axis) of the corresponding PC board.

IC 301 (A, 91, 111) IC NJM2068V

- The expression of the unit in this manual is shown by  $\mu$  instead of  $\mu$ . Please do not make a mistake.

<u>Circuit Symbol and No.</u>	<u>Part No.</u>	<u>Circuit Symbol and No.</u>	<u>Part No.</u>
<b>Unit Number : CWN6303(UC)</b>		IC 332 (B,25,49) IC	NJM4558V
<b>Unit Number : CWN6302(EW5)</b>		IC 351 (A,145,124) IC	NJM2794RB2
<b>Unit Number : CWN6304(ES)</b>		IC 401 (A,154,88) IC	TDA7706
<b>Unit Name : Tuner Amp Unit</b>		IC 481 (A,38,69) IC	TC7SZ04FU
<b>Unit Number : (UC,ES)</b>		IC 591 (B,157,70) IC	S-1155B50-U5
<b>Unit Number : (EW5)</b>		IC 601 (A,96,100) IC(UC)	PEG866A8
<b>Unit Name : Keyboard Unit</b>		(A,96,100) IC(EW5)	PEG865A8
<b>Unit Number : CWX4023</b>		(A,96,100) IC(ES)	PEG864A8
<b>Unit Name : CD Core Unit (S11.6STD)</b>		IC 651 (A,84,114) IC	S-80827CNMC-B8M
<b>Unit Number : CWN6306</b>		IC 661 (A,114,104) EEPROM	BR25L320F-W
<b>Unit Name : Panel Unit</b>		IC 701 (A,66,76) IC	R5S7262ZD144FPU
		IC 751 (B,65,69) SDRAM(16M)	IS42S16400F-7TL
		IC 771 (B,65,88) Flash ROM Unit	PEH322A8
		IC 781 (B,47,60) IC(UC,EW5)	MX25L4006EM2I-12G
		IC 791 (A,63,55) IC	341S2162
		IC 831 (B,8,67) IC	NJM2885DL1-33
		IC 841 (A,159,42) IC	NJM2388F84
		IC 846 (B,155,54) IC	NJM78L05UA
		IC 851 (B,119,47) IC	LT1912EMSE
		IC 871 (B,108,118) IC	TPD1018F
		IC 891 (B,137,58) IC	S-1200B33-M5
		IC 911 (B,82,46) IC	S-1206B12-U3
		IC 912 (B,103,49) IC	S-1172B33-E6
		IC 921 (B,35,31) IC(UC,EW5)	S-1172B18-E6
		IC 922 (B,48,22)Regulator IC(UC,EW5)	S-1170B33UC-OTS

**A**

- Unit Number : CWN6303(UC)**
- Unit Number : CWN6302(EW5)**
- Unit Number : CWN6304(ES)**
- Unit Name : Tuner Amp Unit**

**MISCELLANEOUS**

IC 101 (A,23,67) IC	AK7732VT
IC 131 (B,11,85) IC	PCM1793DB
IC 132 (B,23,85) IC	PCM1793DB
IC 133 (B,35,85) IC	PCM1793DB
IC 161 (B,10,98) IC	LT1358CS8
IC 162 (B,22,98) IC	LT1358CS8
IC 163 (B,33,98) IC	LT1358CS8
IC 201 (B,31,115) IC	NJM4558V
IC 211 (B,59,116) IC	PM9009A
IC 241 (B,31,109) IC	NJM4558V
IC 271 (A,81,142) IC	PA2030A
IC 311 (B,164,117) IC	TC7MB3257FK
IC 331 (B,25,41) IC	NJM4558V

IC 941 (B,117,70) IC	OZ529IGN
IC 942 (B,92,70) IC	OZ529IGN
Q 211 (B,78,110) Transistor	2SC4081
Q 212 (B,67,105) Transistor	UMF23N
Q 213 (B,74,110) Transistor	2SC4081
Q 251 (B,35,126) Transistor	IMH23
Q 252 (B,30,126) Transistor	IMH23
Q 253 (B,25,126) Transistor	IMH23
Q 254 (B,19,126) Transistor	IMH23
Q 255 (B,14,126) Transistor	IMH23
Q 256 (B,8,126) Transistor	IMH23
Q 301 (B,62,132) Chip Transistor	DTC114EUA
Q 303 (B,65,129) Transistor	2SC4081
Q 304 (B,58,136) Chip Transistor	RN4983
Q 305 (A,60,131) Chip Transistor	RN4983
Q 371 (B,108,26) Transistor	2SA1576A

	1	2	3	4
	<u>Circuit Symbol and No.</u>	<u>Part No.</u>	<u>Circuit Symbol and No.</u>	<u>Part No.</u>
			D 943	(B,97,77) Diode DB2X41400
	Q 372	(B,108,32) Transistor 2SA1576A		
	Q 373	(B,108,23) Transistor UMF23N	D 944	(A,124,89) Diode RB050LA-30
A	Q 374	(B,108,29) Transistor UMF23N	D 947	(B,122,78) Diode DB2X41400
	Q 375	(B,102,32) Chip Transistor DTA114EUA	D 981	(B,115,110) Diode 1SS302
	Q 376	(B,102,27) Chip Transistor 2SD2114K	D 982	(B,119,116) Diode RKZ6.2KG(B2)
			D 984	(B,122,116) Diode HZU7L(C2)
	Q 481	(A,36,72) Chip Transistor DTC114EUA		
	Q 501	(A,69,41) Transistor DTA123EU	D 985	(B,120,116) Diode HZU7L(A1)
	Q 601	(A,101,113) Transistor 2SA1576A	D 986	(B,115,120) Diode CRG03
	Q 751	(B,70,53) Transistor 2SA1576A	D 991	(B,135,126) Diode 1SR154-400
	Q 791	(A,70,52) Transistor 2SA1576A	D 992	(B,135,123) Diode 1SR154-400
			L 101	(B,15,67) Inductor CTF1786
	Q 821	(A,123,25) Transistor 2SA1576A		
	Q 822	(A,119,26) Chip Transistor DTC114EUA	L 102	(B,26,61) Inductor CTF1786
	Q 854	(B,132,61) Chip Transistor DTC124EUA	L 131	(A,7,78) Inductor CTF1786
B	Q 861	(B,128,52) Transistor 2SD2153	L 132	(A,14,77) Inductor CTF1786
	Q 862	(B,125,59) Chip Transistor RN4983	L 133	(A,19,77) Inductor CTF1786
			L 134	(A,26,77) Inductor CTF1786
	Q 863	(B,121,57) Digital Transistor DTC144EUA		
	Q 881	(A,136,42) Transistor 2SC3852	L 135	(A,30,77) Inductor CTF1786
	Q 882	(B,137,49) Chip Transistor RN4983	L 136	(A,42,85) Inductor CTF1786
	Q 891	(B,103,10) Transistor 2SA1576A	L 211	(A,71,108) Inductor(UC,ES) LCTAW2R2J2520
				(A,71,108) Inductor(EW5) LCTAW220J2520
	Q 892	(B,103,7) Chip Transistor DTC114EUA	L 311	(A,157,123) Inductor CTF1713
	Q 901	(B,66,43) Chip Transistor 2SB1689	L 312	(A,161,123) Inductor CTF1713
	Q 902	(B,63,44) Chip Transistor DTC114EUA		
	Q 932	(B,115,10) Chip Transistor 2SB1689		
			L 401	(A,163,100) Chip Coil LCTAWR15J2520
			L 402	(A,155,99) Inductor CTF1786
C	Q 933	(B,115,7) Chip Transistor DTC114EUA	L 403	(A,150,99) Inductor CTF1786
	Q 982	(B,121,109) Chip Transistor HN1C01FU	L 404	(A,159,100) Chip Coil LCTAWR27J2520
	Q 983	(B,116,115) Chip Transistor DTC114EUA	L 405	(A,147,102) Inductor CTF1389
	D 211	(B,77,116) Diode RB520S-30		
	D 212	(B,68,112) Diode 1SS400	L 406	(A,145,98) Chip Coil LCTAW4R7J2520
			L 407	(A,165,93) Inductor CTF1786
	D 213	(B,70,117) Diode RB060M-30	L 408	(A,165,92) Inductor CTF1786
	D 214	(B,73,115) Diode RB060M-30	L 409	(A,142,90) Chip Coil LCTAW470J2520
	D 215	(B,133,110) Diode DZ2S068C	L 415	(A,151,79) Inductor CTF1786
	D 216	(B,133,108) Diode DZ2S068C		
	D 301	(B,63,137) Diode RKZ8.2KG(B2)	L 461	(A,85,38) Chip Coil BTH1103
	D 302	(B,62,128) Diode 1SS301	L 481	(A,39,66) Inductor CTF1786
	D 303	(B,62,137) Diode DA2J101	L 482	(A,34,70) Inductor CTF1389
D			L 521	(B,49,124) Inductor(UC,EW5) CTF1786
	D 331	(B,22,54) Diode RKZ3.9KG(B2)	L 522	(B,46,125) Inductor(UC,EW5) CTF1786
	D 371	(B,114,27) Diode RKZ3.9KG(B2)		
	D 372	(B,107,12) Diode DZ2S068C	L 591	(B,150,68) Inductor CTF1793
	D 373	(A,102,25) Diode DZ2S068C	L 601	(A,113,87) Chip Coil BTH1103
	D 401	(A,162,103) Diode KP2311E	L 701	(A,77,55) Inductor CTF1680
	D 402	(A,162,97) Diode KP2311E	L 702	(A,73,54) Inductor CTF1680
			L 703	(A,82,81) Inductor CTF1743
	D 601	(A,94,88) Diode RB551V-30		
	D 602	(A,96,114) Diode RB751S-40	L 751	(B,69,57) Chip Ferrite Bead DTL1107
	D 603	(A,91,113) Diode RB706F-40	L 771	(B,54,96) Inductor CTF1735
	D 801	(A,118,21) Diode DZ2S068C	L 831	(B,12,75) Chip Coil LCTAW1R0J2520
E	D 802	(B,118,23) Diode DZ2S068C	L 832	(A,31,61) Chip Coil LCTAW1R0J2520
			L 851	(A,107,44) Inductor CTH1521
	D 804	(B,115,23) Diode DZ2S068C		
	D 841	(A,151,47) Diode 1SS301	L 853	(B,112,48) Inductor CTF1793
	D 851	(B,111,45) Diode DB2X41400	L 941	(A,103,73) Choke Coil 33 uH CTH1417
	D 852	(B,113,36) Diode CRG03	L 942	(A,128,72) Choke Coil 33 uH CTH1417
	D 853	(A,127,50) Diode 1SR154-400	L 943	(B,97,74) Inductor CTF1793
			L 944	(B,122,74) Inductor CTF1793
	D 855	(B,133,54) Diode DA2J101		
	D 856	(B,111,36) Diode CRG03	L 991	(A,114,141) Choke Coil 600 uH CTH1445
	D 858	(B,107,36) Diode CRG03	X 401	(A,165,85) Oscillator 36.480 MHz CSS1805
	D 861	(B,128,57) Diode HZU6L(B1)	X 481	(A,42,69) Oscillator 16.9644 MHz CWX3849
	D 862	(B,124,56) Diode HZU5LL(B)	X 601	(A,84,100) Oscillator 20.000 MHz CSS1795
F			X 701	(A,66,94) Oscillator 48.000 MHz CSS1760
	D 863	(B,121,54) Diode RKZ3.9KG(B2)		
	D 871	(B,106,125) Diode CRG03	S 351	(B,144,147) Slide Switch(RCA INPUT MODE) ASH1047
	D 872	(B,106,127) Diode CRG03	S 601	(B,156,62) Slide Switch(DSP MODE) ASH1047
	D 881	(B,139,47) Diode RKZ8.2KG(B2)	S 651	(A,22,10) Switch(RESET) CSG1020



5		6		7		8	
<u>Circuit Symbol and No.</u>		<u>Part No.</u>		<u>Circuit Symbol and No.</u>		<u>Part No.</u>	
S 801	(A,92,15) Switch(DSENS)	CSN1039		R 173	(B,20,92)	RS1/16SS153J	
VR331	(A,18,55) Semi-fixed 10 kohm(B)	CCP1448		R 174	(B,19,104)	RS1/16SS153J	
				R 175	(B,26,92)	RS1/16SS153J	
P 251	(B,43,126) Poly Switch	MINISMDC075F/24-2		R 176	(B,25,104)	RS1/16SS153J	A
P 402	(A,156,104) Surge Absorber	IMS A-6803-01Y900					
BZ601	(A,11,44) Buzzer	CPV1062		R 177	(B,21,92)	RS1/16SS153J	
VA311	(A,156,125) Varistor	EZJZ1V800AM		R 178	(B,20,104)	RS1/16SS153J	
VA312	(A,159,125) Varistor	EZJZ1V800AM		R 179	(B,25,92)	RS1/16SS153J	
				R 180	(B,24,104)	RS1/16SS153J	
VA313	(A,166,125) Varistor	EZJZ1V800AM		R 181	(B,22,92)	RS1/16SS681J	
VA314	(A,163,125) Varistor	EZJZ1V800AM					
VA801	(B,109,12) Varistor	VR105C5R0AAA		R 182	(B,21,104)	RS1/16SS681J	
VA802	(B,121,25) Varistor	VR105C5R0AAA		R 183	(B,24,92)	RS1/16SS681J	
VA804	(B,104,24) Varistor	VR105C5R0AAA		R 184	(B,23,104)	RS1/16SS681J	
				R 185	(B,31,92)	RS1/16SS153J	
VA805	(B,112,12) Varistor	VR105C5R0AAA		R 186	(B,30,104)	RS1/16SS153J	
VA806	(B,119,12) Varistor	VR105C5R0AAA					
MC331	(A,9,57) Microphone	CPM1068		R 187	(B,37,92)	RS1/16SS153J	B
CN311	(A,162,135) Connector	YKS5043		R 188	(B,36,104)	RS1/16SS153J	
CN461	(A,94,38) Connector	VKN1192		R 189	(B,32,92)	RS1/16SS153J	
				R 190	(B,31,104)	RS1/16SS153J	
CN501	(A,66,21) Connector	YKS5040		R 191	(B,36,92)	RS1/16SS153J	
CN521	(A,48,42) Connector(UC,EW5)	CKS6346					
CN801	(A,112,15) Connector	CKS3836		R 192	(B,35,104)	RS1/16SS153J	
CN991	(A,116,141) Plug	CKM1586		R 193	(B,33,92)	RS1/16SS681J	
JA251	(A,22,138) Pin Jack	XKB7001		R 194	(B,32,104)	RS1/16SS681J	
				R 195	(B,35,92)	RS1/16SS681J	
JA351	(A,147,141) RCA Jack	CKB1105		R 196	(B,34,104)	RS1/16SS681J	
JA521	(A,45,141) Jack(UC,EW5)	YKS5035					
JA522	(A,45,139) Jack(ES)	CKS6437		R 201	(B,24,116)	RS1/16SS223J	C
⚠	Fuse (10A)	YEK5001		R 202	(B,37,114)	RS1/16SS223J	
				R 203	(B,25,116)	RS1/16SS153J	
				R 204	(B,36,115)	RS1/16SS153J	
				R 205	(B,25,118)	RS1/16SS101J	
				R 206	(B,37,117)	RS1/16SS101J	
R 104	(A,24,56)	RS1/16SS681J		R 207	(B,68,103)	RS1/16SS104J	
R 105	(A,23,56)	RS1/16SS681J		R 208	(B,66,103)	RS1/16SS473J	
R 106	(A,14,71)	RS1/16SS104J		R 209	(B,69,107)	RS1/16SS103J	
R 107	(A,14,72)	RS1/16SS104J		R 211	(B,71,107)	RS1/16SS104J	
R 108	(A,15,68)	RS1/16SS153J					
				R 212	(B,73,104)	RS1/16SS683J	
R 109	(B,33,71)	RS1/16SS0R0J		R 213	(B,73,107)	RS1/16SS153J	D
R 110	(A,25,58)	RS1/16SS471J		R 214	(B,72,104)	RS1/16SS682J	
R 131	(B,8,78)	RAB4CQ101J		R 215	(B,73,108)	RS1/16SS152J	
R 132	(B,6,78)	RS1/16SS473J		R 216	(B,59,125)	RS1/16SS390J	
R 133	(B,5,81)	RS1/16SS0R0J					
				R 217	(B,58,125)	RS1/16SS390J	
R 136	(B,20,78)	RAB4CQ101J		R 218	(B,57,125)	RS1/16SS390J	
R 137	(B,18,78)	RS1/16SS473J		R 219	(B,56,125)	RS1/16SS390J	
R 138	(B,17,80)	RS1/16SS0R0J		R 220	(B,55,125)	RS1/16SS390J	
R 141	(B,32,78)	RAB4CQ101J		R 221	(B,54,125)	RS1/16SS390J	
R 142	(B,30,78)	RS1/16SS473J					
				R 226	(B,67,108)	RS1/16SS393J	
R 143	(B,29,81)	RS1/16SS0R0J		R 227	(B,69,121)	RAB4CQ101J	
R 147	(B,11,78)	RS1/16SS0R0J		R 228	(A,62,125)	RS1/10SR0R0J	E
R 149	(B,23,78)	RS1/16SS0R0J		R 241	(B,38,109)	RS1/16SS332J	
R 151	(B,35,78)	RS1/16SS0R0J		R 242	(B,33,112)	RS1/16SS563J	
R 161	(B,8,92)	RS1/16SS153J					
				R 243	(B,33,113)	RS1/16SS682J	
R 162	(B,7,104)	RS1/16SS153J		R 244	(B,31,112)	RS1/16SS473J	
R 163	(B,14,92)	RS1/16SS153J		R 251	(B,10,123)	RS1/16SS390J	
R 164	(B,13,104)	RS1/16SS153J		R 252	(B,27,123)	RS1/16SS390J	
R 165	(B,9,92)	RS1/16SS153J		R 253	(B,16,123)	RS1/16SS390J	
R 166	(B,8,104)	RS1/16SS153J					
				R 254	(B,32,123)	RS1/16SS390J	
R 167	(B,13,92)	RS1/16SS153J		R 255	(B,21,123)	RS1/16SS390J	
R 168	(B,12,104)	RS1/16SS153J		R 256	(B,38,123)	RS1/16SS390J	
R 169	(B,10,92)	RS1/16SS681J		R 257	(B,11,125)	RS1/16SS223J	F
R 170	(B,9,104)	RS1/16SS681J		R 258	(B,27,125)	RS1/16SS223J	
R 171	(B,12,92)	RS1/16SS681J					
				R 259	(B,16,125)	RS1/16SS223J	
R 172	(B,11,104)	RS1/16SS681J					

**RESISTORS**

1

2

3

4

**Circuit Symbol and No.****Part No.****Circuit Symbol and No.****Part No.**

R 260	(B,33,125)	RS1/16SS223J	R 382	(B,111,27)	RS1/16SS152J
R 261	(B,22,125)	RS1/16SS223J	R 383	(B,114,29)	RS1/16SS122J
R 262	(B,38,125)	RS1/16SS223J	R 385	(B,113,25)	RS1/16SS104J
R 271	(A,61,133)	RS1/16SS103J	R 386	(A,110,25)	RS1/10SR101J
R 301	(B,59,128)	RS1/16SS103J	R 387	(A,106,25)	RS1/10SR101J
R 302	(B,58,129)	RS1/16SS103J	R 388	(A,108,25)	RS1/10SR101J
R 303	(B,60,129)	RS1/16SS331J	R 389	(A,109,23)	RS1/16SS223J
R 305	(B,64,133)	RS1/16SS473J	R 390	(A,107,23)	RS1/16SS223J
R 306	(B,64,132)	RS1/16SS104J	R 394	(A,97,20)	RS1/10SR101J
R 307	(B,66,127)	RS1/16SS473J	R 401	(A,165,103)	RS1/16SS221J
R 308	(A,58,130)	RS1/16SS473J	R 402	(A,165,97)	RS1/16SS751J
R 309	(B,60,136)	RS1/16SS102J	R 403	(A,143,99)	RS1/16SS391J
R 311	(B,163,122)	RS1/16SS1003D	R 405	(A,147,95)	RS1/16SS105J
R 312	(B,168,116)	RS1/16SS102J	R 406	(A,142,94)	RS1/16SS471J
R 313	(B,160,116)	RS1/16SS5R6J	R 407	(A,144,93)	RS1/16SS330J
R 314	(B,161,116)	RS1/16SS5R6J	R 408	(A,143,87)	RS1/16SS681J
R 315	(B,168,117)	RS1/16SS102J	R 410	(A,138,83)	RS1/4SA8R2J
R 316	(B,164,122)	RS1/16SS7502D	R 412	(A,138,86)	RS1/4SA8R2J
R 317	(B,160,119)	RS1/16SS1003D	R 413	(A,152,104)	RS1/16SS105J
R 318	(B,159,119)	RS1/16SS1003D	R 414	(A,153,75)	RS1/10SR0R0J
R 319	(B,162,122)	RS1/16SS1003D	R 415	(A,153,66)	RS1/10SR0R0J
R 322	(B,161,118)	RS1/16SS4302D	R 421	(A,157,77)	RS1/16SS0R0J
R 326	(A,63,133)	RS1/16SS103J	R 427	(A,147,83)	RS1/16SS102J
R 331	(B,22,47)	RS1/16SS103J	R 428	(A,143,85)	RS1/16SS0R0J
R 332	(B,30,50)	RS1/16SS153J	R 461	(B,88,44)	RS1/16SS472J
R 333	(B,30,48)	RS1/16SS153J	R 462	(B,88,43)	RS1/16SS473J
R 334	(B,20,47)	RS1/16SS103J	R 463	(B,88,42)	RS1/16SS472J
R 335	(B,31,42)	RS1/10SR223J	R 464	(B,88,40)	RS1/16SS472J
R 336	(B,20,50)	RS1/16SS102J	R 465	(A,88,44)	RS1/16SS221J
R 337	(B,20,48)	RS1/16SS563J	R 466	(A,88,43)	RS1/16SS221J
R 338	(B,18,47)	RS1/10SR101J	R 467	(A,88,42)	RS1/16SS101J
R 339	(B,20,52)	RS1/16SS152J	R 468	(A,88,41)	RS1/16SS221J
R 340	(B,18,52)	RS1/16SS152J	R 469	(A,88,40)	RS1/16SS101J
R 341	(B,20,51)	RS1/16SS104J	R 470	(A,88,39)	RS1/16SS102J
R 342	(B,17,52)	RS1/16SS222J	R 471	(A,88,36)	RS1/16SS151J
R 355	(A,142,130)	RS1/10SR102J	R 472	(A,88,35)	RS1/16SS101J
R 356	(A,140,130)	RS1/10SR102J	R 473	(A,88,34)	RS1/16SS151J
R 357	(A,145,130)	RS1/10SR102J	R 474	(A,88,30)	RS1/16SS221J
R 358	(A,143,130)	RS1/10SR102J	R 475	(B,86,40)	RS1/16SS104J
R 359	(A,151,130)	RS1/10SR102J	R 476	(A,88,31)	RS1/16SS104J
R 360	(A,149,130)	RS1/10SR102J	R 477	(B,88,39)	RS1/16SS104J
R 361	(A,148,130)	RS1/10SR102J	R 482	(A,40,64)	RS1/16SS0R0J
R 362	(A,146,130)	RS1/10SR102J	R 501	(A,76,38)	RS1/16SS151J
R 363	(A,141,128)	RS1/10SR223J	R 502	(A,58,38)	RS1/16SS151J
R 364	(A,147,128)	RS1/10SR223J	R 503	(A,60,38)	RS1/16SS151J
R 365	(A,144,127)	RS1/10SR221J	R 504	(A,64,38)	RS1/16SS0R0J
R 366	(A,150,127)	RS1/10SR221J	R 505	(A,71,38)	RS1/16SS221J
R 367	(A,144,128)	RS1/10SR121J	R 506	(A,74,38)	RS1/16SS151J
R 368	(A,150,128)	RS1/10SR121J	R 507	(A,69,38)	RS1/16SS221J
R 371	(B,106,26)	RS1/16SS104J	R 509	(A,59,41)	RAB4CQ473J
R 372	(B,105,32)	RS1/16SS104J	R 510	(A,73,42)	RAB4CQ473J
R 373	(B,106,25)	RS1/16SS473J	R 524	(B,47,125) (UC,EW5)	RS1/16SS0R0J
R 374	(B,105,29)	RS1/16SS473J	R 528	(B,41,41) (UC,EW5)	RS1/16SS0R0J
R 375	(B,111,24)	RS1/16SS104J	R 529	(B,41,43) (UC,EW5)	RS1/16SS0R0J
R 376	(B,111,30)	RS1/16SS104J	R 530	(B,41,42) (UC,EW5)	RS1/16SS102J
R 377	(B,111,23)	RS1/16SS473J	R 532	(B,41,38) (UC,EW5)	RS1/16SS101J
R 378	(B,111,29)	RS1/16SS473J	R 534	(B,41,37) (UC,EW5)	RS1/16SS101J
R 379	(B,102,29)	RS1/16SS103J	R 536	(B,50,47) (UC,EW5)	RS1/16SS102J
R 380	(B,111,31)	RS1/16SS472J	R 537	(B,50,46) (UC,EW5)	RS1/16SS102J
R 381	(B,104,32)	RS1/16SS102J	R 539	(B,49,51) (UC,EW5)	RS1/16SS1001D
			R 540	(B,52,124)	RS1/10SR102J

1

2

3

4

5		6		7		8	
<u>Circuit Symbol and No.</u>		<u>Part No.</u>		<u>Circuit Symbol and No.</u>		<u>Part No.</u>	
R 541	(B,50,124)	RS1/10SR102J		R 713	(A,66,91)	RS1/16SS102J	
R 601	(A,85,105)	RS1/16SS104J		R 714	(A,62,94)	RS1/16SS472J	
R 602	(A,85,104)	RS1/16SS104J		R 717	(B,65,95)	RS1/16SS473J	A
R 603	(B,88,103)	RS1/16SS104J		R 718	(B,65,96)	RS1/16SS101J	
R 604	(B,107,96)	RS1/16SS104J		R 719	(B,64,95)	RS1/16SS5601F	
R 605	(A,104,113)	RS1/16SS103J		R 720	(A,51,88)	RS1/16SS102J	
R 606	(A,104,112)	RS1/16SS103J		R 721	(A,57,93)	RS1/16SS473J	
R 607	(B,102,108)	RS1/16SS104J		R 722	(A,50,86)	RAB4CQ472J	
R 608	(B,86,99)	RS1/16SS104J		R 723	(A,48,81)	RS1/16SS473J	
R 609	(B,94,98) (UC,EW5)	RS1/16SS104J		R 724	(A,48,80)	RS1/16SS473J	
R 610	(A,85,107)	RS1/16SS102J		R 725	(B,52,72)	RS1/16SS221J	
R 611	(B,88,102)	RS1/16SS472J		R 727	(B,52,67)	RS1/16SS0R0J	
R 612	(A,86,99)	RS1/16SS105J		R 729	(B,52,69)	RS1/16SS0R0J	
R 613	(A,86,101)	RS1/16SS101J		R 730	(B,52,70)	RS1/16SS0R0J	B
R 614	(B,88,99)	RS1/16SS104J		R 733	(A,49,64) (ES)	RS1/16SS473J	
R 615	(A,86,93)	RS1/16SS222J		R 735	(A,56,61)	RS1/16SS101J	
R 616	(B,89,95) (UC,EW5)	RS1/16SS104J		R 736	(A,57,61)	RS1/16SS101J	
R 618	(B,85,97)	RS1/16SS104J		R 737	(A,58,59)	RS1/16SS101J	
R 619	(B,85,99)	RS1/16SS104J		R 738	(A,79,62)	RS1/16SS101J	
R 620	(A,90,89)	RS1/16SS104J		R 739	(A,79,63)	RS1/16SS101J	
R 622	(B,94,92)	RS1/16SS104J		R 741	(A,81,65)	RS1/16SS0R0J	
R 623	(B,95,92)	RS1/16SS104J		R 742	(A,81,66)	RS1/16SS0R0J	
R 624	(A,95,87)	RS1/16SS104J		R 743	(A,81,67)	RS1/16SS0R0J	
R 625	(B,96,94)	RS1/16SS104J		R 744	(A,83,66)	RS1/16SS472J	
R 626	(B,97,94)	RS1/16SS104J		R 745	(A,57,95) (UC,EW5)	RS1/16SS473J	C
R 627	(B,98,94)	RS1/16SS104J		R 746	(A,57,94) (ES)	RS1/16SS0R0J	
R 628	(A,95,89)	RS1/16SS472J		R 747	(B,52,73)	RS1/16SS0R0J	
R 629	(B,98,92)	RS1/16SS104J		R 748	(B,52,74)	RS1/16SS0R0J	
R 631	(B,103,99)	RS1/16SS104J		R 753	(B,66,61)	RS1/16SS220J	
R 632	(B,103,100)	RS1/16SS104J		R 755	(B,67,77)	RAB4CQ220J	
R 633	(A,98,87)	RS1/16SS104J		R 756	(B,70,77)	RAB4CQ220J	
R 634	(A,96,113)	RS1/16SS103J		R 757	(B,73,77)	RAB4CQ220J	
R 635	(A,98,113)	RS1/16SS104J		R 758	(B,71,60)	RAB4CQ220J	
R 636	(B,103,108)	RS1/16SS104J		R 759	(B,74,60)	RAB4CQ220J	
R 637	(A,85,103)	RS1/16SS104J		R 763	(B,68,80)	RS1/16SS472J	
R 638	(A,104,111)	RS1/16SS0R0J		R 764	(B,74,54)	RS1/16SS472J	D
R 639	(A,106,107)	RS1/16SS0R0J		R 765	(B,73,53)	RS1/16SS103J	
R 641	(A,94,113)	RS1/16SS104J		R 771	(B,78,88)	RS1/16SS101J	
R 642	(A,93,112)	RS1/16SS104J		R 772	(B,61,80)	RS1/16SS472J	
R 643	(B,97,113)	RS1/16SS472J		R 773	(B,60,80)	RS1/16SS472J	
R 644	(B,138,65)	RS1/16SS0R0J		R 775	(B,52,93)	RAB4CQ221J	
R 645	(B,141,63)	RS1/16SS473J		R 776	(B,52,90)	RAB4CQ221J	
R 646	(A,99,113)	RS1/16SS103J		R 777	(B,50,86)	RAB4CQ221J	
R 648	(A,100,111)	RS1/16SS472J		R 778	(B,53,84)	RAB4CQ221J	
R 651	(A,84,111)	RS1/16SS104J		R 781	(B,48,66) (UC,EW5)	RS1/16SS0R0J	
R 652	(A,84,112)	RS1/16SS152J		R 784	(B,51,56) (UC,EW5)	RS1/16SS101J	
R 661	(A,118,104)	RS1/16SS104J		R 785	(B,51,59) (UC,EW5)	RS1/16SS101J	E
R 663	(A,107,101)	RAB4CQ681J		R 786	(B,44,66) (UC,EW5)	RS1/16SS101J	
R 664	(A,115,100)	RS1/16SS104J		R 787	(B,45,66) (UC,EW5)	RS1/16SS101J	
R 665	(A,118,106)	RS1/16SS104J		R 788	(B,46,66) (UC,EW5)	RS1/16SS473J	
R 666	(A,118,105)	RS1/16SS104J		R 791	(A,67,53)	RS1/16SS473J	
R 672	(A,118,96)	RS1/16SS104J		R 792	(A,70,54)	RS1/16SS472J	
R 702	(A,81,87)	RS1/16SS473J		R 793	(A,63,61)	RS1/16SS101J	
R 703	(A,81,89)	RS1/16SS101J		R 794	(A,62,61)	RS1/16SS101J	
R 705	(A,81,71)	RAB4CQ101J		R 795	(B,64,57)	RS1/16SS103J	
R 706	(A,83,80)	RS1/16SS101J		R 796	(B,63,57)	RS1/16SS103J	
R 707	(A,76,92)	RS1/16SS473J		R 799	(A,63,50)	RS1/16SS272J	F
R 708	(A,75,92)	RS1/16SS473J		R 800	(A,64,50)	RS1/16SS472J	
R 709	(A,74,92)	RS1/16SS473J		R 802	(B,120,10)	RS1/10SR222J	
R 710	(A,73,92)	RS1/16SS473J		R 803	(B,120,25)	RS1/10SR222J	

1

2

3

4

Circuit Symbol and No.Part No.Circuit Symbol and No.Part No.

R 804	(B,112,10)	RS1/10SR222J
R 805	(B,103,24)	RS1/10SR222J
R 806	(B,122,8)	RS1/10SR222J
R 810	(B,110,10)	RS1/10SR222J
R 816	(A,94,20)	RS1/16SS102J
R 817	(A,95,20)	RS1/16SS104J
R 818	(B,118,25)	RS1/10SR222J
R 819	(A,117,23)	RS1/10SR222J
R 820	(B,117,25)	RS1/10SR222J
R 821	(A,120,30)	RS1/10SR242J
R 822	(A,121,26)	RS1/16SS473J
R 823	(A,120,24)	RS1/16SS103J
R 842	(A,149,43)	RS1/10SR473J
R 851	(B,122,45)	RS1/16SS134J
R 852	(B,123,45)	RS1/16SS103J
R 853	(B,122,49)	RS1/16SS104J
R 854	(B,115,49)	RS1/16SS474J
R 855	(B,125,48)	RS1/16SS4703D
R 856	(B,124,48)	RS1/16SS8202D
R 857	(B,124,49)	RS1/16SS1003D
R 859	(B,130,62)	RS1/16SS0R0J
R 861	(B,124,57)	RS1/16SS223J
R 862	(B,123,58)	RS1/16SS272J
R 871	(B,109,114)	RS1/16SS102J
R 881	(B,135,47)	RS1/10SR821J
R 882	(B,141,48)	RS1/16SS473J
R 883	(B,141,50)	RS1/16SS103J
R 884	(A,98,27)	RS1/10SR0R0J
R 891	(B,100,9)	RS1/16SS103J
R 892	(B,100,7)	RS1/16SS102J
R 901	(B,66,46)	RS1/16SS103J
R 902	(B,64,46)	RS1/16SS681J
R 903	(A,61,41)	RS1/16SS153J
R 921	(A,113,66)	RS1/16SS102J
R 922	(A,90,66)	RS1/16SS102J
R 923	(A,113,65)	RS1/16SS102J
R 924	(A,90,65)	RS1/16SS102J
R 925	(A,113,64)	RS1/16SS102J
R 926	(A,90,64)	RS1/16SS102J
R 933	(B,118,10)	RS1/16SS103J
R 934	(B,113,8)	RS1/16SS822J
R 935	(B,117,12)	RS1/16SS473J
R 941	(B,124,68)	RS1/16SS3902D
R 942	(B,123,68)	RS1/16SS1201D
R 943	(B,123,67)	RS1/16SS1002D
R 946	(B,99,68)	RS1/16SS3902D
R 947	(B,98,68)	RS1/16SS1201D
R 948	(B,98,67)	RS1/16SS1002D
R 951	(A,108,65)	RS1/16SS102J
R 952	(A,107,65)	RS1/16SS102J
R 953	(A,113,67)	RS1/16SS102J
R 954	(A,90,67)	RS1/16SS102J
R 955	(A,94,66)	RS1/8SQ0R0J
R 956	(B,87,69)	RS1/16SS0R0J
R 957	(B,87,72)	RS1/16SS104J
R 959	(B,87,67)	RS1/16SS1002D
R 960	(B,87,66)	RS1/16SS393J
R 961	(B,95,64)	RS1/16SS0R0J
R 963	(A,120,67)	RS1/8SQ0R0J
R 964	(B,112,64)	RS1/16SS101J

R 965	(B,88,64)	RS1/16SS101J
R 966	(B,112,69)	RS1/16SS0R0J
R 967	(B,112,72)	RS1/16SS104J
R 969	(B,112,67)	RS1/16SS1002D
R 970	(B,112,66)	RS1/16SS393J
R 971	(B,120,64)	RS1/16SS0R0J
R 972	(A,132,65)	RS1/16SS102J
R 973	(A,131,65)	RS1/16SS102J
R 974	(B,120,63)	RS1/16SS0R0J
R 975	(B,94,76)	RS1/16SS0R0J
R 981	(B,122,112)	RS1/16SS104J
R 982	(B,117,109)	RS1/16SS102J
R 983	(B,119,113)	RS1/16SS153J
R 984	(B,118,112)	RS1/16SS223J
R 985	(B,118,122)	RS1/16SS392J
R 989	(B,121,112)	RS1/16SS103J
R 990	(B,123,113)	RS1/16SS473J
R 991	(B,120,113)	RS1/16SS473J
R 992	(B,120,122)	RS1/16SS472J
R 993	(B,116,117)	RS1/16SS103J
R 994	(B,116,125)	RS1/4SA102J
R 995	(B,119,125)	RS1/4SA102J

CAPACITORS

C 101	(A,32,65)	CKSSYB104K10
C 102	(A,25,59)	CKSSYB104K10
C 103	(A,23,75)	CKSSYB104K10
C 104	(A,22,59)	CKSSYB104K10
C 105	(A,17,73)	CKSSYB104K10
C 106	(A,14,64) 10 uF	CCG1234
C 107	(A,13,67) 10 uF	CCG1234
C 108	(A,13,70) 10 uF	CCG1234
C 109	(A,15,64)	CKSSYB104K10
C 110	(A,15,66)	CKSSYB104K10
C 111	(A,14,69)	CKSSYB682K25
C 112	(A,14,66)	CKSSYB104K10
C 113	(B,13,66) 2.2 uF	CCG1218
C 114	(B,15,66)	CKSSYB103K16
C 115	(B,23,62) 2.2 uF	CCG1218
C 116	(B,25,61)	CKSSYB103K16
C 117	(B,15,68)	CKSSYB473K16
C 118	(B,28,61)	CKSSYB473K16
C 119	(B,29,65)	CCSSCH470J50
C 120	(B,29,67)	CCSSCH470J50
C 121	(B,29,68)	CCSSCH470J50
C 122	(B,29,72)	CCSSCH470J50
C 123	(B,28,72)	CCSSCH470J50
C 124	(B,26,72)	CCSSCH470J50
C 125	(B,25,72)	CCSSCH470J50
C 126	(B,24,72)	CCSSCH470J50
C 127	(A,5,77) 0.1 uF	CCG1321
C 128	(A,20,78) 0.1 uF	CCG1321
C 129	(A,32,78) 0.1 uF	CCG1321
C 130	(A,35,78)	CKSSYB103K16
C 135	(A,9,78)	CKSSYB102K50
C 136	(A,7,82) 10 uF/25 V	CCH1939
C 137	(B,5,85)	CKSSYB102K50
C 138	(A,14,75)	CKSSYB102K50
C 139	(A,13,82) 10 uF/25 V	CCH1939

1

2

3

4

5  
**Circuit Symbol and No.**

6  
**Part No.**

7  
**Circuit Symbol and No.**

8  
**Part No.**

C 140	(B,16,86)	CKSSYB102K50	C 207	(B,31,119) 2.2 uF	CCG1218
C 141	(B,9,91)	CKSSYB105K6R3	C 208	(B,34,118) 2.2 uF	CCG1218
C 142	(A,21,77)	CKSSYB102K50	C 209	(B,28,118)	CKSSYB104K10
C 143	(A,19,82) 10 uF/25 V	CCH1939	C 211	(B,59,107) 2.2 uF	CCG1218
C 144	(B,17,85)	CKSSYB102K50	C 212	(B,58,107) 2.2 uF	CCG1218
C 145	(A,26,76)	CKSSYB102K50	C 214	(B,71,108)	CKSSYB681K50
C 146	(A,25,82) 10 uF/25 V	CCH1939	C 215	(B,71,104) 2.2 uF	CCG1218
C 147	(B,28,85)	CKSSYB102K50	C 216	(B,65,107) 2.2 uF	CCG1218
C 148	(B,21,91)	CKSSYB105K6R3	C 217	(B,63,107) 2.2 uF	CCG1218
C 149	(A,29,77)	CKSSYB102K50	C 218	(B,62,107) 2.2 uF	CCG1218
C 150	(A,31,82) 10 uF/25 V	CCH1939	C 219	(B,61,107) 2.2 uF	CCG1218
C 151	(B,30,85)	CKSSYB102K50	C 220	(B,68,110) 0.1 uF	CCG1321
C 152	(A,43,83)	CKSSYB102K50	C 222	(B,56,107) 2.2 uF	CCG1218
C 153	(A,37,82) 10 uF/25 V	CCH1939	C 223	(B,55,107)	CKSSYB104K10
C 154	(B,40,86)	CKSSYB102K50	C 224	(B,54,107)	CKSSYB104K10
C 155	(B,33,91)	CKSSYB105K6R3	C 225	(B,49,111) 10 uF	DCH1165
C 156	(A,41,83) 0.1 uF	CCG1321	C 226	(B,49,116) 10 uF	DCH1165
C 157	(A,26,78) 0.1 uF	CCG1321	C 227	(A,13,115) 10 uF/25 V	CCH1939
C 158	(A,14,78) 0.1 uF	CCG1321	C 228	(A,25,115) 10 uF/25 V	CCH1939
C 159	(A,11,78)	CKSSYB103K16	C 229	(A,7,115) 10 uF/25 V	CCH1939
C 160	(A,23,78)	CKSSYB103K16	C 230	(A,19,115) 10 uF/25 V	CCH1939
C 161	(A,7,90) 10 uF/16 V	CCH1934	C 231	(A,37,115) 10 uF/25 V	CCH1939
C 162	(A,7,98) 10 uF/16 V	CCH1934	C 232	(A,31,115) 10 uF/25 V	CCH1939
C 163	(A,13,90) 10 uF/16 V	CCH1934	C 233	(A,65,120) 47 uF/16 V	CCH1940
C 164	(A,13,98) 10 uF/16 V	CCH1934	C 234	(B,75,115) 4.7 uF	CCG1326
C 165	(B,10,93)	CCSSCH221J50	C 235	(A,65,110) 47 uF/16 V	CCH1940
C 166	(B,9,103)	CCSSCH221J50	C 236	(B,69,113) 4.7 uF	CCG1326
C 167	(B,12,93)	CCSSCH221J50	C 237	(B,68,116) 1 uF	CCG1325
C 168	(B,12,103)	CCSSCH221J50	C 238	(B,67,107)	CKSSYB104K10
C 169	(B,11,92)	CCSSCH821J50	C 239	(A,72,110) 0.1 uF	CCG1321
C 170	(B,10,104)	CCSSCH821J50	C 240	(A,70,111) 10 uF	CCG1236
C 171	(A,19,90) 10 uF/16 V	CCH1934	C 241	(A,31,107) 10 uF/16 V	CCH1998
C 172	(A,19,98) 10 uF/16 V	CCH1934	C 242	(B,28,112) 10 uF	CCG1234
C 173	(A,25,90) 10 uF/16 V	CCH1934	C 243	(B,32,106) 0.1 uF	CCG1321
C 174	(A,25,98) 10 uF/16 V	CCH1934	C 251	(A,7,124) 10 uF/25 V	CCH1939
C 175	(B,22,94)	CCSSCH221J50	C 252	(A,25,124) 10 uF/25 V	CCH1939
C 176	(B,21,103)	CCSSCH221J50	C 253	(A,13,124) 10 uF/25 V	CCH1939
C 177	(B,24,94)	CCSSCH221J50	C 254	(A,31,124) 10 uF/25 V	CCH1939
C 178	(B,23,103)	CCSSCH221J50	C 255	(A,19,124) 10 uF/25 V	CCH1939
C 179	(B,23,92)	CCSSCH821J50	C 256	(A,37,124) 10 uF/25 V	CCH1939
C 180	(B,22,104)	CCSSCH821J50	C 263	(B,7,131)	CKSRYB103K50
C 181	(A,31,90) 10 uF/16 V	CCH1934	C 275	(B,78,127)	CCG1333
C 182	(A,31,98) 10 uF/16 V	CCH1934	C 276	(B,74,127)	CCG1333
C 183	(A,37,90) 10 uF/16 V	CCH1934	C 277	(B,83,127)	CCG1333
C 184	(A,37,98) 10 uF/16 V	CCH1934	C 278	(B,87,127)	CCG1333
C 185	(B,33,94)	CCSSCH221J50	C 279	(B,78,130)	CCG1333
C 186	(B,32,103)	CCSSCH221J50	C 280	(B,74,130)	CCG1333
C 187	(B,36,94)	CCSSCH221J50	C 281	(B,83,130)	CCG1333
C 188	(B,34,103)	CCSSCH221J50	C 282	(B,87,130)	CCG1333
C 189	(B,34,92)	CCSSCH821J50	C 291	(A,127,123) 3 000 uF/16 V	CCH2043
C 190	(B,33,104)	CCSSCH821J50	C 292	(B,94,131)	CKSSYB104K16
C 194	(B,6,94) 0.1 uF	CCG1321	C 293	(A,75,130) 4.7 uF	CCG1326
C 195	(B,18,94) 0.1 uF	CCG1321	C 294	(A,70,130) 4.7 uF	CCG1326
C 196	(B,29,94) 0.1 uF	CCG1321	C 297	(A,79,127) 10 uF/16 V	CCH1998
C 201	(B,27,116)	CCSSCH220J50	C 298	(B,93,131) 0.1 uF	CCG1321
C 202	(B,37,115)	CCSSCH220J50	C 299	(B,97,131) 0.1 uF	CCG1321
C 203	(B,32,121)	CKSSYB332K50	C 300	(B,95,131)	CKSSYB104K16
C 204	(B,37,118)	CKSSYB332K50	C 301	(B,58,132) 10 uF	CCG1332
C 205	(B,26,120) 2.2 uF	CCG1218	C 302	(A,57,125) Capacitor	CEVW220M16
C 206	(B,39,115) 2.2 uF	CCG1218	C 311	(B,168,121)	CKSSYB104K10

	1	2	3	4
	<u>Circuit Symbol and No.</u>	<u>Part No.</u>	<u>Circuit Symbol and No.</u>	<u>Part No.</u>
A	C 312 (B,163,136)	CKSRYB104K16	C 445 (A,147,97)	CKSSYB223K16
	C 313 (B,167,122)	CKSRYB104K16	C 447 (A,147,82)	CKSSYB102K50
	C 314 (A,112,82)	CKSSYB103K16	C 451 (A,145,101) (UC,ES)	CCSSCJ3R0C50
	C 335 (B,25,46)	CKSRYB105K10	C 457 (A,163,105) (UC,ES)	CCSSCK2R0C50
	C 336 (B,22,46) 4.7 uF	CCG1212	C 461 (A,89,37)	CKSSYB104K10
■	C 337 (B,31,43) 4.7 uF	CCG1212	C 463 (B,88,34)	CCSSCH470J50
	C 338 (B,29,46)	CKSRYB105K10	C 464 (B,88,35)	CCSSCH100D50
	C 339 (B,30,46)	CKSRYB474K10	C 465 (B,88,36)	CCSSCH470J50
	C 340 (B,32,45)	CKSSYB104K10	C 466 (B,86,41)	CKSSYB103K16
	C 341 (B,21,48)	CCSSCH101J50	C 467 (A,83,36) 0.1 uF	CCG1321
B	C 342 (B,31,40)	CKSRYB105K10	C 481 (A,34,72)	CCSSCH121J50
	C 343 (A,30,56)	CEVW100M16	C 482 (A,42,67) 2.2 uF	CCG1218
	C 344 (B,22,44)	CKSRYB105K10	C 483 (A,41,71)	CKSSYB103K16
	C 345 (B,22,52)	CKSSYB105K6R3	C 485 (A,37,66) 2.2 uF	CCG1218
	C 346 (B,18,50)	CKSSYB105K6R3	C 486 (A,38,66)	CKSSYB103K16
■	C 351 (A,138,123)	CEVW100M16	C 487 (A,33,69)	CCSSCH330J50
	C 352 (A,152,121) Capacitor	CEVW220M16	C 488 (A,35,69)	CCSSCH151J50
	C 353 (A,145,122)	CKSRYB104K16	C 494 (B,22,66)	CKSRYB103K50
	C 362 (A,139,128)	CKSRYB105K16	C 502 (A,66,37)	CKSSYB104K10
	C 363 (A,141,127)	CKSRYB105K16	C 504 (B,76,39)	CCSSCH100D50
C	C 364 (A,150,125)	CKSRYB105K16	C 505 (B,73,39)	CCSSCH100D50
	C 365 (A,147,127)	CKSRYB105K16	C 506 (A,61,38)	CCSSCH100D50
	C 371 (B,111,25)	CKSSYB471K50	C 507 (A,57,38)	CCSSCH100D50
	C 372 (A,110,22)	CKSRYB221K50	C 508 (A,72,37)	CCSSCH100D50
	C 373 (A,106,22)	CKSRYB221K50	C 522 (B,35,40) 10 uF(UC,EW5)	CCG1192
■	C 374 (B,107,11)	CKSRYB104K16	C 523 (B,36,40) 10 uF(UC,EW5)	CCG1192
	C 401 (A,159,103)	CCSSCH330J50	C 525 (B,48,50) (UC,EW5)	CKSRYB105K16
	C 402 (A,161,102)	CCSSCH6R0D50	C 527 (A,51,57) Capacitor(UC,EW5)	CEVW221M4
	C 403 (A,164,102)	CKSSYB103K16	C 528 (A,43,57) Capacitor(UC,EW5)	CEVW221M4
	C 404 (A,154,98)	CKSSYB104K10	C 591 (B,152,67)	CKSQYB334K50
D	C 405 (A,151,97)	CKSSYB104K10	C 592 (A,147,71) Capacitor	CEVW220M16
	C 406 (A,164,98)	CKSSYB103K16	C 593 (B,152,72) 2.2 uF	CCG1218
	C 407 (A,152,98)	CKSSYB104K10	C 601 (A,92,110)	CKSSYB104K10
	C 409 (A,165,98)	CKSSYB103K16	C 602 (A,109,87) 10 uF	CCG1192
	C 410 (A,152,96)	CKSSYB103K16	C 605 (A,81,101)	CCSSCH100D50
■	C 411 (A,150,97)	CKSSYB103K16	C 606 (A,81,99)	CCSSCH100D50
	C 412 (A,148,98) 10 uF	CCG1192	C 607 (A,85,97)	CKSSYB104K10
	C 413 (A,158,97)	CKSSYB103K16	C 609 (A,106,99)	CKSSYB104K10
	C 414 (A,156,100)	CKSRYB105K10	C 610 (A,85,102)	CKSSYB104K10
	C 415 (A,146,95)	CKSSYB103K16	C 611 (B,106,92)	CKSRYB104K16
E	C 416 (A,162,94)	CKSRYB224K16	C 651 (B,22,17)	CKSSYB105K6R3
	C 417 (A,164,93)	CKSSYB104K10	C 652 (A,86,115)	CKSSYB105K6R3
	C 418 (A,143,95) 10 uF	CCG1192	C 661 (A,117,100)	CKSSYB104K10
	C 419 (A,162,91)	CKSRYB105K10	C 701 (A,76,54) 1 uF	CCG1325
	C 420 (A,144,94)	CKSSYB104K10	C 703 (A,76,57) 10 uF	CCG1192
■	C 421 (A,142,93)	CCSSCH101J50	C 704 (A,74,52) 1 uF	CCG1325
	C 422 (A,145,90)	CKSSYB104K10	C 706 (A,74,56) 10 uF	CCG1192
	C 423 (A,142,92)	CKSSYB103K16	C 707 (A,81,68)	CKSSYB104K10
	C 424 (A,166,89)	CKSSYB472K25	C 708 (A,81,69)	CKSSYB104K10
	C 425 (A,166,90)	CKSSYB472K25	C 709 (A,81,74)	CKSSYB104K10
F	C 426 (A,162,88)	CKSSYB104K10	C 710 (A,81,75)	CKSSYB104K10
	C 427 (A,143,88)	CCSSCH820J50	C 711 (A,82,80)	CKSSYB104K10
	C 428 (A,165,87)	CCSSCH9R0D50	C 712 (A,81,82)	CKSSYB104K10
	C 429 (A,165,82)	CCSSCH9R0D50	C 713 (A,81,85)	CKSSYB104K10
	C 430 (A,143,83) 4.7 uF	CCG1212	C 714 (A,80,86)	CKSSYB104K10
■	C 431 (A,162,84)	CKSSYB104K10	C 715 (A,79,89)	CKSSYB103K16
	C 437 (A,160,79)	CKSSYB104K10	C 716 (A,78,91)	CKSSYB104K10
	C 440 (A,152,80)	CKSSYB104K10	C 719 (A,72,92)	CKSSYB104K10
	C 441 (A,156,79) 2.2 uF	CCG1218	C 720 (A,69,91)	CKSSYB104K10
	C 443 (A,150,102)	CKSSYB103K16	C 721 (A,67,91)	CKSSYB104K10

5  
**Circuit Symbol and No.**

6  
**Part No.**

7  
**Circuit Symbol and No.**

8  
**Part No.**

C 722	(A,64,91)	CKSSYB104K10	C 848	(B,160,53) 0.1 uF	CCG1321
C 723	(A,65,97)	CCSSCH100D50	C 852	(B,123,44)	CKSSYB471K50
C 724	(A,67,97)	CCSSCH100D50	C 853	(B,123,46)	CCSSCH470J50
C 725	(A,61,91)	CKSSYB104K10	C 854	(B,116,49)	CKSSYB333K16
C 726	(A,60,91)	CKSSYB104K10	C 855	(B,115,46)	CKSRYB474K16
C 727	(A,58,92)	CKSSYB104K10	C 856	(B,113,50) 4.7 uF	CCG1222
C 728	(A,58,91)	CKSSYB104K10	C 857	(B,112,41) 22 uF	CCG1274
C 729	(A,55,91)	CKSSYB104K10	C 858	(B,112,43) 22 uF	CCG1274
C 730	(A,55,92)	CKSSYB104K10	C 859	(B,124,47)	CCSSCH100D50
C 731	(A,49,84)	CKSSYB104K10	C 860	(A,114,56)	CEHAT102M16
C 732	(A,50,83)	CKSSYB104K10	C 861	(B,127,56)	CKSSYB103K16
C 733	(A,50,78)	CKSSYB104K10	C 862	(B,132,52)	CKSSYB104K10
C 734	(A,50,77)	CKSSYB104K10	C 863	(B,109,47)	CKSSYB102K50
C 735	(A,51,72)	CKSSYB104K10	C 871	(B,106,123)	CKSSYB473K16
C 736	(A,49,71)	CKSSYB104K10	C 872	(B,109,123)	CKSSYB104K16
C 737	(A,50,66)	CKSSYB104K10	C 874	(B,109,127)	CKSSYB104K16
C 738	(A,51,64)	CKSSYB104K10	C 881	(A,145,43) 10 uF	CCG1192
C 739	(A,59,61)	CKSSYB104K10	C 882	(A,145,50) Capacitor	CEHVW101M16
C 740	(A,61,61)	CKSSYB104K10	C 883	(B,140,49)	CKSSYB473K16
C 741	(A,65,61)	CKSSYB104K10	C 884	(A,140,62) 1 uF	CCG1305
C 742	(A,68,61)	CKSSYB104K10	C 885	(A,145,41) 1 uF	CCG1325
C 743	(A,73,61)	CKSSYB104K10	C 892	(B,137,60)	CKSSYB104K10
C 744	(A,75,61)	CKSSYB104K10	C 893	(B,137,54) 4.7 uF	CCG1201
C 745	(B,65,94)	CKSSYB105K6R3	C 894	(B,137,55)	CKSSYB104K10
C 746	(A,72,95)	CKSSYB102K50	C 895	(B,99,9)	CKSSYB104K10
C 748	(A,56,58)	CCSSCH220J50	C 896	(B,104,11)	CKSSYB104K10
C 749	(A,57,56)	CCSSCH220J50	C 901	(B,68,46)	CKSSYB104K10
C 750	(A,58,56)	CCSSCH220J50	C 902	(B,65,41)	CKSSYB104K10
C 761	(A,83,78)	CCSSCH100D50	C 911	(B,84,43)	CKSSYB104K10
C 768	(B,52,71)	CCSSCH8R0D50	C 914	(B,85,47)	CKSSYB104K10
C 769	(B,70,55)	CKSSYB102K50	C 915	(B,97,51) 10 uF	CCG1234
C 770	(B,55,77)	CKSSYB104K10	C 916	(B,105,44) 4.7 uF	CCG1201
C 771	(B,56,77)	CKSSYB104K10	C 921	(B,29,30) 4.7 uF(UC,EW5)	CCG1212
C 772	(B,60,61)	CKSSYB104K10	C 924	(B,38,28) 4.7 uF(UC,EW5)	CCG1212
C 773	(B,61,77)	CKSSYB104K10	C 925	(B,45,26) 4.7 uF(UC,EW5)	CCG1212
C 774	(B,64,61)	CKSSYB104K10	C 928	(B,45,17) 4.7 uF(UC,EW5)	CCG1212
C 775	(B,64,76)	CKSSYB104K10	C 929	(B,115,12)	CKSRYB104K16
C 776	(B,75,77)	CKSSYB104K10	C 941	(A,114,78) 47 uF	CCG1256
C 778	(B,58,97) 10 uF	CCG1192	C 942	(B,121,68)	CKSSYB681K50
C 779	(B,53,95)	CKSSYB104K10	C 943	(A,113,69) 47 uF	CCG1251
C 780	(B,53,88)	CKSSYB104K10	C 944	(B,124,65) 47 uF	CCG1251
C 781	(B,78,87)	CKSSYB103K16	C 945	(B,112,68)	CKSSYB104K10
C 782	(B,48,54) (UC,EW5)	CKSSYB104K10	C 946	(B,96,68)	CKSSYB681K50
C 791	(A,66,53)	CKSSYB104K10	C 947	(A,89,69) 47 uF	CCG1251
C 792	(A,64,52)	CKSSYB104K10	C 948	(B,99,64) 47 uF	CCG1251
C 801	(B,122,9)	CCSSCH101J50	C 949	(B,87,68)	CKSSYB104K10
C 803	(A,101,21)	CKSRYB104K16	C 950	(B,86,73) 2.2 uF	CCG1218
C 804	(B,121,12)	CCSSCH101J50	C 951	(A,89,78) 47 uF	CCG1256
C 831	(B,5,75) 4.7 uF	CCG1201	C 952	(B,87,70)	CKSSYB103K16
C 832	(B,14,73)	CKSSYB104K10	C 953	(B,96,74)	CKSSYB103K16
C 833	(A,36,57)	CEVW101M16	C 954	(A,101,64) 22 uF	CCG1274
C 834	(A,8,69)	CEVW101M16	C 956	(B,122,71)	CKSRYB105K16
C 835	(B,15,69)	CCSSCH101J50	C 958	(B,97,71)	CKSRYB105K16
C 836	(A,38,63)	CCSSCH101J50	C 963	(B,110,73) 2.2 uF	CCG1218
C 837	(B,15,71) 4.7 uF	CCG1326	C 964	(B,112,70)	CKSSYB103K16
C 838	(A,6,64) 0.1 uF	CCG1321	C 965	(B,121,74)	CKSSYB103K16
C 841	(A,163,44)	CKSQYB334K50	C 966	(A,127,65) 22 uF	CCG1274
C 842	(A,157,50) 220 uF/16 V	CCH1990	C 967	(B,96,77)	CKSSYB102K50
C 846	(B,159,50) 4.7 uF	CCG1201	C 968	(B,121,77)	CKSSYB102K50
C 847	(B,160,56) 0.1 uF	CCG1321	C 981	(B,118,111)	CKSSYB104K10

**1**  
Circuit Symbol and No.

**2**  
Part No.

**3**  
Circuit Symbol and No.

**4**  
Part No.

JA1981 (A,159,27) Jack

YKN5006

C 982 (B,119,122) CKSSYB104K16  
C 983 (B,120,121) CKSSYB104K16  
C 984 (B,117,119) CKSRYB105K16

**RESISTORS**

R 1801 (B,123,14) RS1/10SR222J  
R 1802 (B,125,14) RS1/10SR222J  
R 1803 (A,121,29) RS1/10SR104J  
R 1811 (B,53,23) RS1/16SS103J  
R 1821 (A,133,17) RS1/10SR272J

R 1822 (A,130,17) RS1/10SR272J  
R 1823 (A,131,17) RS1/10SR272J  
R 1831 (A,123,18) RS1/16SS102J  
R 1832 (A,124,20) RS1/16SS102J  
R 1833 (A,124,18) RS1/16SS102J

R 1834 (B,41,29) RS1/16SS101J  
R 1835 (B,45,14) RS1/16SS101J  
R 1836 (B,40,29) RS1/16SS101J  
R 1837 (B,47,12) RS1/16SS101J  
R 1838 (B,47,29) RS1/16SS101J

R 1839 (B,46,29) RS1/16SS101J  
R 1840 (B,38,36) RS1/10SR181J  
R 1841 (B,41,36) RS1/10SR181J  
R 1842 (B,43,36) RS1/10SR181J  
R 1843 (B,45,36) RS1/10SR181J

R 1844 (B,45,6) RS1/10SR181J  
R 1845 (B,48,6) RS1/10SR181J  
R 1861 (A,131,26) RS1/16SS102J  
R 1862 (A,133,25) RS1/16SS102J  
R 1863 (A,131,25) RS1/16SS102J

R 1870 (A,80,32) RS1/16SS101J  
R 1871 (A,128,27) RS1/16SS101J  
R 1872 (A,79,32) RS1/16SS101J  
R 1873 (A,130,27) RS1/16SS101J  
R 1874 (A,81,32) RS1/16SS101J

R 1875 (A,82,32) RS1/16SS101J  
R 1876 (B,71,39) RS1/10SR181J  
R 1877 (B,79,39) RS1/10SR181J  
R 1878 (B,82,36) RS1/10SR181J  
R 1879 (B,80,36) RS1/10SR181J

R 1880 (B,118,38) RS1/10SR181J  
R 1881 (B,136,38) RS1/10SR181J  
R 1901 (A,110,16) RS1/16SS472J  
R 1902 (B,93,18) RS1/16SS102J  
R 1903 (A,113,19) RS1/16SS154J

R 1904 (A,108,22) RS1/16SS473J  
R 1905 (A,107,23) RS1/16SS102J  
R 1906 (B,94,22) RAB4CQ102J  
R 1907 (A,107,24) RS1/16SS103J  
R 1908 (A,110,26) RAB4CQ103J

R 1909 (A,102,30) RS1/16SS103J  
R 1910 (A,99,30) RAB4CQ473J  
R 1911 (A,96,31) RS1/16SS473J  
R 1912 (A,94,30) RS1/16SS473J  
R 1913 (B,93,19) RS1/16SS101J

R 1914 (A,80,30) RS1/16SS101J  
R 1915 (A,92,30) RAB4CQ101J  
R 1916 (A,86,26) RS1/16SS101J  
R 1917 (A,86,24) RAB4CQ101J  
R 1918 (A,84,21) RAB4CQ101J

R 1919 (B,93,16) RAB4CQ101J

**B**  
**Unit Number : (UC,ES)**  
**Unit Number : (EW5)**  
**Unit Name : Keyboard Unit**

**MISCELLANEOUS**

IC 1821 (A,130,21) IC BH2228FV  
IC 1901 (A,97,20) IC PEG870A8  
IC 1902 (B,81,19) Flash ROM Unit(UC,ES) PEH366A8  
(B,81,19) Flash ROM Unit(EW5) PEH368A8  
IC 1931 (A,158,14) IR RC REC MODULE PNJ4833M  
Q 1831 (B,58,10) Transistor 2SC4081

Q 1832 (B,54,10) Transistor 2SC4081  
Q 1833 (B,51,10) Transistor 2SC4081  
Q 1834 (B,39,32) Chip Transistor HN1C01FU  
Q 1835 (B,46,32) Chip Transistor HN1C01FU  
Q 1836 (B,45,11) Chip Transistor HN1C01FU

Q 1861 (A,143,23) Transistor 2SC4081  
Q 1862 (A,143,18) Transistor 2SC4081  
Q 1863 (A,143,13) Transistor 2SC4081  
Q 1864 (B,75,37) Chip Transistor HN1C01FU  
Q 1865 (B,80,33) Chip Transistor HN1C01FU

Q 1866 (A,129,29) Chip Transistor HN1C01FU  
D 1803 (A,135,32) Diode CRG03  
D 1831 (A,9,26) LED SMLV56RGB1U1(Q)  
D 1832 (A,51,34) LED SMLV56RGB1U1(Q)  
D 1833 (A,51,20) LED SMLV56RGB1U1(Q)

D 1834 (A,67,26) LED SMLV56RGB1U1(Q)  
D 1861 (A,87,37) LED SMLV56RGB1U1(Q)  
D 1862 (A,105,37) LED SMLV56RGB1U1(Q)  
D 1863 (A,123,37) LED SMLV56RGB1U1(Q)  
D 1864 (A,141,37) LED SMLV56RGB1U1(Q)

D 1901 (A,112,19) Diode DA2J101  
L 1981 (B,150,30) Inductor CTF1389  
L 1982 (B,150,32) Inductor CTF1389  
L 1983 (B,150,29) Inductor CTF1389  
TH1901 (A,98,8) Thermistor CCX1079

X 1901 (A,108,18) Ceramic Resonator 16.000 MHz CSS1616  
S 1811 (A,25,26) Encoder(MULTI-CONTROL)CSD1168  
S 1931 (A,8,39) Push Switch CSG1155  
S 1932 (A,63,27) Push Switch CSG1155  
S 1933 (A,61,16) Push Switch CSG1155

S 1935 (A,40,40) Push Switch CSG1155  
S 1937 (A,67,13) Push Switch CSG1155  
S 1938 (A,60,40) Push Switch CSG1155  
S 1939 (A,40,12) Push Switch CSG1155  
S 1940 (A,30,10) Spring Switch CSN1080

S 1941 (A,21,10) Spring Switch CSN1081  
S 1942 (A,67,39) Push Switch CSG1155  
VA1981 (B,150,33) Diode DZ2S068C  
VA1982 (B,149,28) Diode DZ2S068C  
CN1801 (B,131,26) Connector CKS6038

CN1951 (B,105,38) Connector CKS6228



5  
**Circuit Symbol and No.**

6  
**Part No.**

R 1920	(B,93,13)	RAB4CQ101J
R 1921	(A,86,16)	RAB4CQ101J
R 1922	(B,79,11)	RAB4CQ101J
R 1923	(B,84,11)	RAB4CQ101J
R 1924	(A,78,13)	RAB4CQ101J
R 1925	(A,100,9)	RAB4CQ102J
R 1926	(A,114,15)	RS1/16SS104J
R 1931	(B,147,18)	RS1/16SS470J
R 1953	(B,108,30)	RAB4CQ473J
R 1954	(A,107,28)	RS1/16SS473J
R 1955	(A,114,26)	RAB4CQ101J
R 1957	(A,98,9)	RS1/16SS2202D

**CAPACITORS**

C 1821	(A,135,20)	CKSSYB103K16
C 1822	(A,135,19)	CKSRYB105K10
C 1834	(A,9,22)	CKSRYB104K16
C 1835	(A,12,27)	CKSRYB104K16
C 1836	(A,11,22)	CKSRYB104K16
C 1837	(A,65,23)	CKSRYB104K16
C 1838	(A,69,23)	CKSRYB104K16
C 1839	(A,71,23)	CKSRYB104K16
C 1840	(A,51,30)	CKSRYB104K16
C 1841	(A,51,29)	CKSRYB104K16
C 1842	(A,52,37)	CKSRYB104K16
C 1843	(A,51,23)	CKSRYB104K16
C 1844	(A,51,16)	CKSRYB104K16
C 1845	(A,51,18)	CKSRYB104K16
C 1864	(A,90,35)	CKSRYB104K16
C 1865	(A,83,38)	CKSRYB104K16
C 1866	(A,86,34)	CKSRYB104K16
C 1867	(A,102,35)	CKSRYB104K16
C 1868	(A,101,39)	CKSRYB104K16
C 1869	(A,102,37)	CKSRYB104K16
C 1870	(A,121,33)	CKSRYB104K16
C 1871	(A,119,38)	CKSRYB104K16
C 1872	(A,124,34)	CKSRYB104K16
C 1873	(A,138,35)	CKSRYB104K16
C 1874	(A,134,39)	CKSRYB104K16
C 1875	(A,135,36)	CKSRYB104K16
C 1903	(A,114,19)	CKSSYB104K10
C 1904	(A,108,21)	CKSSYB103K16
C 1905	(A,87,20)	CKSSYB103K16
C 1906	(B,69,16)	CKSSYB103K16
C 1931	(B,150,19) 10 uF	CCG1192
C 1951	(A,96,34)	CKSQYB334K50
C 1952	(B,100,31) 4.7 uF	CCG1212
C 1953	(B,99,32) 4.7 uF	CCG1212
C 1954	(B,102,31) 4.7 uF	CCG1212
C 1955	(B,103,32) 4.7 uF	CCG1212
C 1957	(B,100,27)	CKSSYB105K6R3
C 1983	(B,146,27)	CKSRYB104K16

7  
**Circuit Symbol and No.**

8  
**Part No.**

IC 201	(B,23,37) IC	PE5791A
IC 301	(A,37,11) IC	BD8223EFV
Q 101	(B,11,53) Transistor	2SA1577
Q 102	(B,15,54) Transistor	DTA123JU
X 201	(B,25,49) Ceramic Resonator	16.934 MHz CSS1603
S 901	(A,42,53) Spring Switch(HOME)	CSN1080
S 903	(B,21,12) Spring Switch(DSCSNS)	CSN1081
CN101	(A,16,58) Connector	CKS4808
CN701	(A,25,29) Connector	CKS6146

**RESISTORS**

R 101	(B,6,57)	RS1/10SR2R4J
R 102	(B,8,57)	RS1/10SR2R4J
R 103	(B,9,57)	RS1/10SR2R7J
R 108	(B,18,55)	RS1/16SS105J
R 109	(B,12,50)	RS1/16SS222J
R 201	(A,24,11)	RS1/16SS0R0J
R 202	(A,23,9)	RS1/16SS0R0J
R 214	(B,18,28)	RS1/16SS103J
R 215	(B,17,28)	RS1/16SS393J
R 216	(B,12,35)	RS1/16SS122J
R 217	(B,10,32)	RS1/16SS562J
R 218	(B,10,35)	RS1/16SS472J
R 229	(B,12,34)	RS1/16SS471J
R 232	(A,31,54)	RS1/16SS0R0J
R 237	(B,33,45)	RS1/16SS221J
R 240	(B,34,40)	RS1/16SS473J
R 245	(A,34,46)	RS1/16SS104J
R 254	(A,37,56)	RS1/16SS104J
R 260	(B,30,27)	RS1/16SS103J
R 264	(A,22,9)	RS1/16SS102J
R 281	(B,33,38)	RS1/16SS560J
R 282	(B,33,39)	RS1/16SS560J
R 283	(B,35,38)	RS1/16SS0R0J
R 291	(B,33,34)	RS1/16SS560J
R 292	(B,33,36)	RS1/16SS0R0J
R 293	(B,35,39)	RS1/16SS0R0J
R 294	(B,27,48)	RS1/16SS471J
R 296	(B,34,43)	RS1/16SS0R0J
R 301	(A,27,9)	RS1/16SS0R0J
R 302	(A,28,9)	RS1/16SS0R0J
R 303	(A,27,11)	RS1/16SS123J
R 304	(A,28,11)	RS1/16SS123J
R 305	(A,26,9)	RS1/16SS102J
R 306	(A,26,11)	RS1/16SS472J
R 307	(A,25,9)	RS1/16SS102J
R 308	(A,25,11)	RS1/16SS472J
R 309	(A,35,6)	RS1/16SS473J
R 310	(B,30,9)	RS1/16SS472J
R 311	(B,30,10)	RS1/16SS472J
R 312	(B,30,11)	RS1/16SS472J
R 313	(B,30,12)	RS1/16SS472J
R 701	(A,21,38)	RS1/16SS101J
R 702	(A,23,38)	RS1/16SS101J
R 706	(A,32,42)	RS1/16SS221J
R 708	(B,28,26)	RS1/16SS0R0J
R 709	(B,29,28)	RS1/16SS0R0J

**CAPACITORS**



**Unit Number : CWX4023**  
**Unit Name : CD Core Unit (S11.6STD)**

**MISCELLANEOUS**

**Circuit Symbol and No.****Part No.**

A	C 104	(B,12,57)	CKSQYB475K6R3
	C 203	(B,22,47)	CKSSYB104K10
	C 209	(B,28,47)	CKSRYB104K16
	C 210	(B,33,43)	CKSSYB104K10
	C 211	(B,33,41)	CKSSYB104K10
	C 212	(B,22,28)	CKSSYB104K10
	C 213	(B,18,26)	CKSSYB332K50
	C 214	(B,17,26)	CKSSYB473K16
	C 215	(B,19,28)	CKSSYB104K10
	C 216	(B,12,33)	CKSSYB182K50
	C 217	(B,10,34)	CCSSCH560J50
	C 218	(B,10,36)	CCSSCH4R0C50
	C 219	(B,14,34)	CKSSYB104K10
B	C 220	(A,18,38)	CKSSYB104K10
	C 221	(B,14,32)	CKSSYB104K10
	C 222	(B,13,37)	CKSSYB104K10
	C 223	(B,12,42)	CCSSCH680J50
	C 224	(B,13,45)	CCSSCH470J50
	C 225	(B,13,46)	CKSSYB103K16
	C 228	(B,10,33)	CCSSCH270J50
	C 229	(B,9,40)	CKSSYB104K10
	C 233	(B,32,46)	CKSSYB103K16
	C 236	(B,8,40)	CKSSYB104K10
	C 238	(A,25,44)	CKSRYB104K16
C	C 299	(A,26,41)	CKSSYB104K10
	C 302	(B,28,12)	CKSSYB102K50
	C 303	(B,29,12)	CKSSYB102K50
	C 304	(B,27,12)	CKSSYB223K16
	C 305	(B,26,12)	CKSSYB104K10
	C 306	(A,31,7)	CKSSYB104K10
	C 307	(A,41,19)	CKSRYB105K10
	C 308	(A,31,15)	CKSRYB105K10
	C 710	(A,34,42)	CKSSYB102K50

D

**D****Unit Number : CWN6306****Unit Name : Panel Unit****MISCELLANEOUS**

D 1	(A,4,17) LED	CL-197HB1-D(CDE)	
D 2	(A,55,37) LED	CL-197HB1-D(CDE)	
S 1	(A,59,37) Push Switch(EJECT)	CSG1155	
CN1	(A,39,24) Connector	CKS6037	
E	CN2	(B,17,10) Connector	CKS3863

**Miscellaneous Parts List**

M 1	Pickup Unit(P10.6)(Service)	CXX3556
M 2	Motor Unit(SPDL)	CXE2273
M 2	Motor Unit(LOAD/CRG)	CXC4026

F