

MRV-1507

ALPINE SERVICE MANUAL

2/1 Channel Power Amplifier

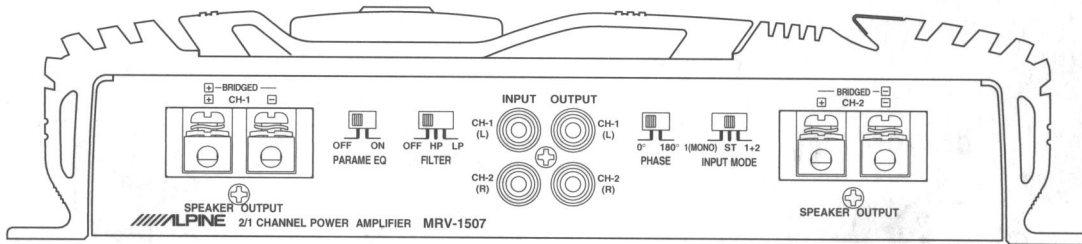

サービス費用区分	B
技術資料No.	PM-79-O

MRV-1507

Contents

Packing Assembly Parts List	3
Packing Method View	3
Specifications	4
Adjustment Procedures	5
Block Diagram	6
Parts Layout on P.W. Boards and Wiring Diagram (1/5)	7, 8
Parts Layout on P.W. Boards and Wiring Diagram (2/5)	9, 10
Parts Layout on P.W. Boards and Wiring Diagram (3/5)	11, 12
Parts Layout on P.W. Boards and Wiring Diagram (4/5)	13, 14
Parts Layout on P.W. Boards and Wiring Diagram (5/5)	15, 16
Schematic Diagram (1/4)	17 to 19
Schematic Diagram (2/4)	20 to 22
Schematic Diagram (3/4)	23 to 25
Schematic Diagram (4/4)	26 to 28
Electrical Parts List	29 to 38
Exploded View (Cabinet)	39, 40
Cabinet Assembly Parts List	41

Packing Assembly Parts List

Symbol No.	Part No.	Description	Symbol No.	Part No.	Description
○ 101-1	01T25258Y01	Assy., Terminal Adaptor	101-9	65E29465S01	Fuse, Auto 80A (For Battery Line)
101-2	03E11447S01	Screw, TPG (M4X14)	101-10	01E29401S01	Assy., Remote Wire
101-3	03E29353S01	Screw (M4X10)	○ 102	68P11199Y97	Owner's Manual
101-4	03E29533S01	Screw (M5X6)	△ 102-1	68P11199Y98	Owner's Manual (ENGLISH/FRANCAIS/ESPANOL)
101-5	75E29296S01	Housing Rubber-A	△ 102-2	68P11199Y99	Owner's Manual (DEUTSCH/ITALIANO/SVENSKA)
101-6	75E29586S01	Housing Rubber-E	□ 102	68P20877Y01	Owner's Manual
101-7	01E29587S01	Wrench (2.5X2.9mm)			
101-8	01E28659S01	Wrench (2X2.3mm)			

NOTE : ○ : For North American Model Only, △ : For General Foreign Model Only,
 □ : For Japanese Model Only, Others : Common.

Packing Method View

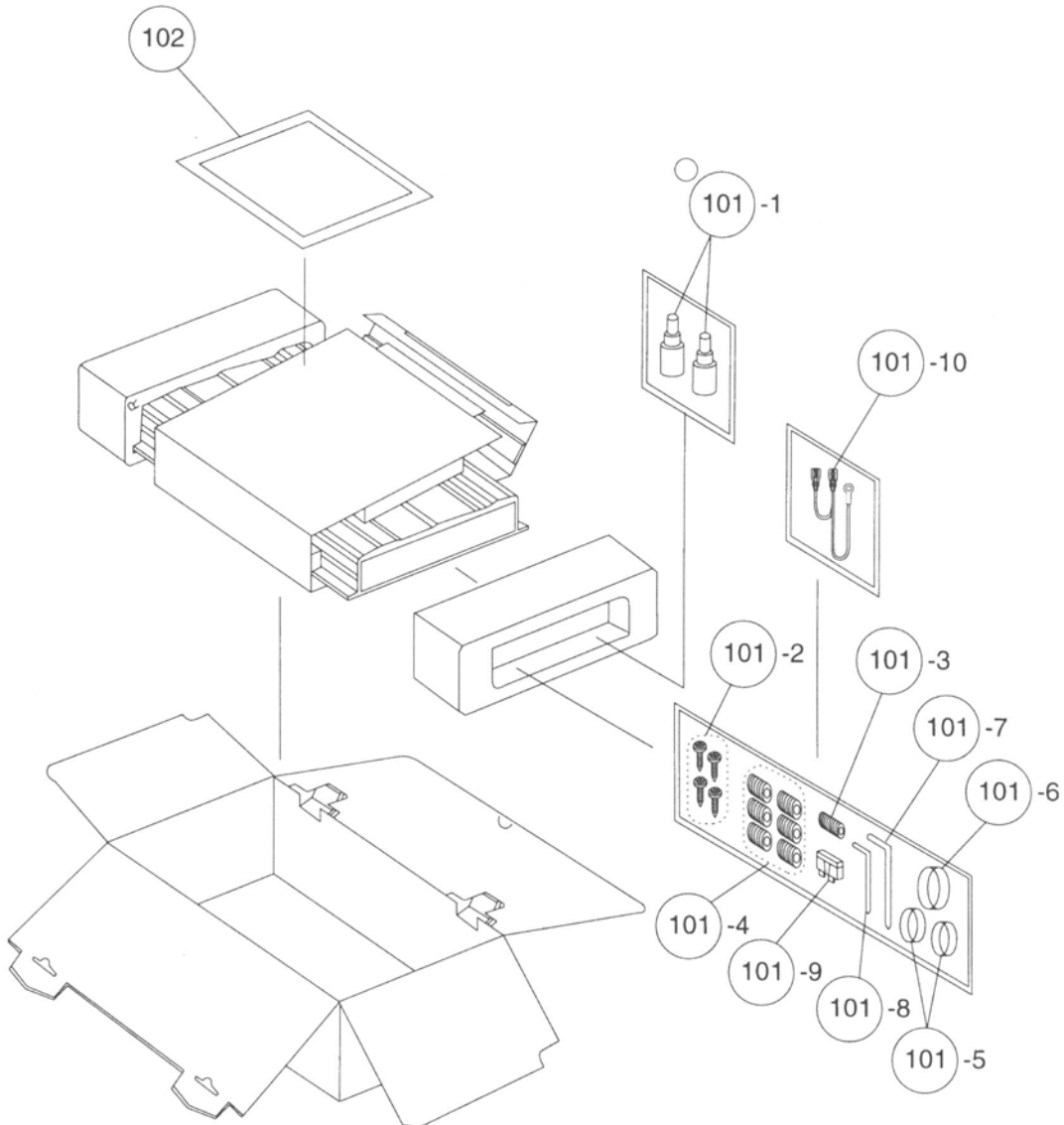

NOTE : ○ : For North American Model Only, Others : Common.

Specifications

T.H.D. <BATTERY NORMAL>	
(Stereo, 20Hz/1kHz/20kHz)	200W/ch, 4ohm-2channel, 14.4V, L.P.F.-80kHz : 0.2%
	150W/ch, 4ohm-2channel, 12V, L.P.F.-80kHz : 0.2%
	350W/ch, 2ohm-2channel, 14.4V, L.P.F.-80kHz : 0.8%
	200W/ch, 2ohm-2channel, 12V, L.P.F.-80kHz : 0.8%
(BTL, INPUT MODE MONO, 20Hz/1kHz/20kHz)	750W/ch, 4ohm-1channel, 14.4V, L.P.F.-80kHz : 0.8%
	500W/ch, 4ohm-1channel, 12V, L.P.F.-80kHz : 0.8%
Power Output <BATTERY NORMAL>	
(Stereo, 20Hz/1kHz/20kHz)	4ohm-2channel, 0.2% T.H.D., 14.4V, L.P.F.-80kHz : 225W
	4ohm-2channel, 0.2% T.H.D., 12V, L.P.F.-80kHz : 150W
	2ohm-2channel, 0.8% T.H.D., 14.4V, L.P.F.-80kHz : 380W
	2ohm-2channel, 0.8% T.H.D., 12V, L.P.F.-80kHz : 250W
(BTL, INPUT MODE MONO, 20Hz/1kHz/20kHz)	4ohm-1channel, 0.8% T.H.D., 14.4V, L.P.F.-80kHz : 800W
	4ohm-1channel, 0.3% T.H.D., 12V, L.P.F.-80kHz : 500W
<BATTERY DIRECT>	
(BTL, INPUT MODE MONO, 1kHz)	4ohm-1channel, 0.8% T.H.D., 14.4V, L.P.F.-80kHz : 800W
	4ohm-1channel, 0.8% T.H.D., 12V, L.P.F.-80kHz : 500W
S/N Ratio (Ref. Output 225W/4ohm, Input shorted)	100dB
Input Sensitivity (225W Output)	GAIN-VR (NORM) : 1V±3dB
	GAIN-VR (MAX) : 0.2V±3dB
	GAIN-VR (MIN) : 4V±3dB
(PREOUT Level, 1V Output)	1V±2dB
Input Impedance	22kohm±10%
Frequency Response (0±1dB, Ref. 1kHz)	20Hz~40kHz
Current Drain	No Signal : 3A
	4ohm-2channel, 0.2% T.H.D. : 65A
	2ohm-2channel, 0.8% T.H.D. : 120A
	4ohm-1channel, BTL, 0.8% T.H.D. : 120A
Residual Noise (Input Shorted, 4ohm-2channel)	VR Center, MIN. : 3mV
	VR MAX. : 6mV
Channel Separation (Input Shorted, 1kHz, 225W)	55dB
Remote on Voltage	6.5±1V
Remote Current Drain	1.3±0.5mA
Back Up Current Drain (REMOTE OFF)	1.2mA
Fuse Requirement	80A (For Battery Line)
Power Source	DC14.4V (11~16V)
Dimensions (W×H×D)	260×60×530mm
Weight	8.95kg

NOTE : Due to Continuing product improvement, specifications and designs are subject to change without notice.

Adjustment Procedures

1. Power Supply Voltage Adjustment

電源電圧調整

(1) Connection

接続

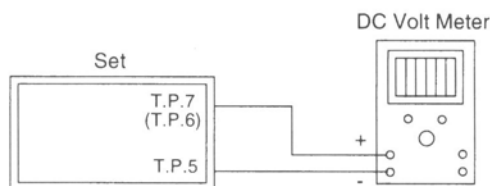

Figure 1
1図

BATTERY : DC14.4V
BATTERY DIRECT : OPEN
REMOTE : DC6.5±1V
No Signal Input

(2) Adjustment Procedures

調整方法

- ① Adjust VR601 so that Voltage between T.P.7 and T.P.5 reaches $49\pm 0.5V$.

T.P.7とT.P.5との間の電圧が $49\pm 0.5V$ になる様にVR601で調整する。

- ② Adjust VR602 so that Voltage between T.P.6 and T.P.5 reaches $-49\pm 0.5V$.

T.P.6とT.P.5との間の電圧が $-49\pm 0.5V$ になる様にVR602で調整する。

2. Idling Adjustment

アイドリング調整

(1) Connection

接続

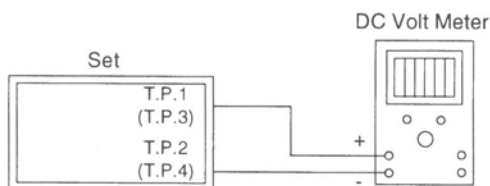

Figure 2
2図

BATTERY : DC14.4V
BATTERY DIRECT : OPEN
REMOTE : DC6.5±1V
No Signal Input

(2) Adjustment Procedures

調整方法

- ① Adjust VR402 so that Voltage between T.P.1 and T.P.2 reaches $1\pm 0.6mV$.

T.P.1とT.P.2との間の電圧が $1\pm 0.6mV$ になる様にVR402で調整する。

- ② Adjust VR401 so that Voltage between T.P.3 and T.P.4 reaches $1\pm 0.6mV$.

T.P.3とT.P.4との間の電圧が $1\pm 0.6mV$ になる様にVR401で調整する。

NOTE : For the Adjustment Parts and Test Points, refer to the Parts Layout on P.W. Boards and Wiring Diagram.

注記：調整部品及びテストポイントの詳細については、「Parts Layout on P.W. Boards and Wiring Diagram」を参照願います。

Block Diagram

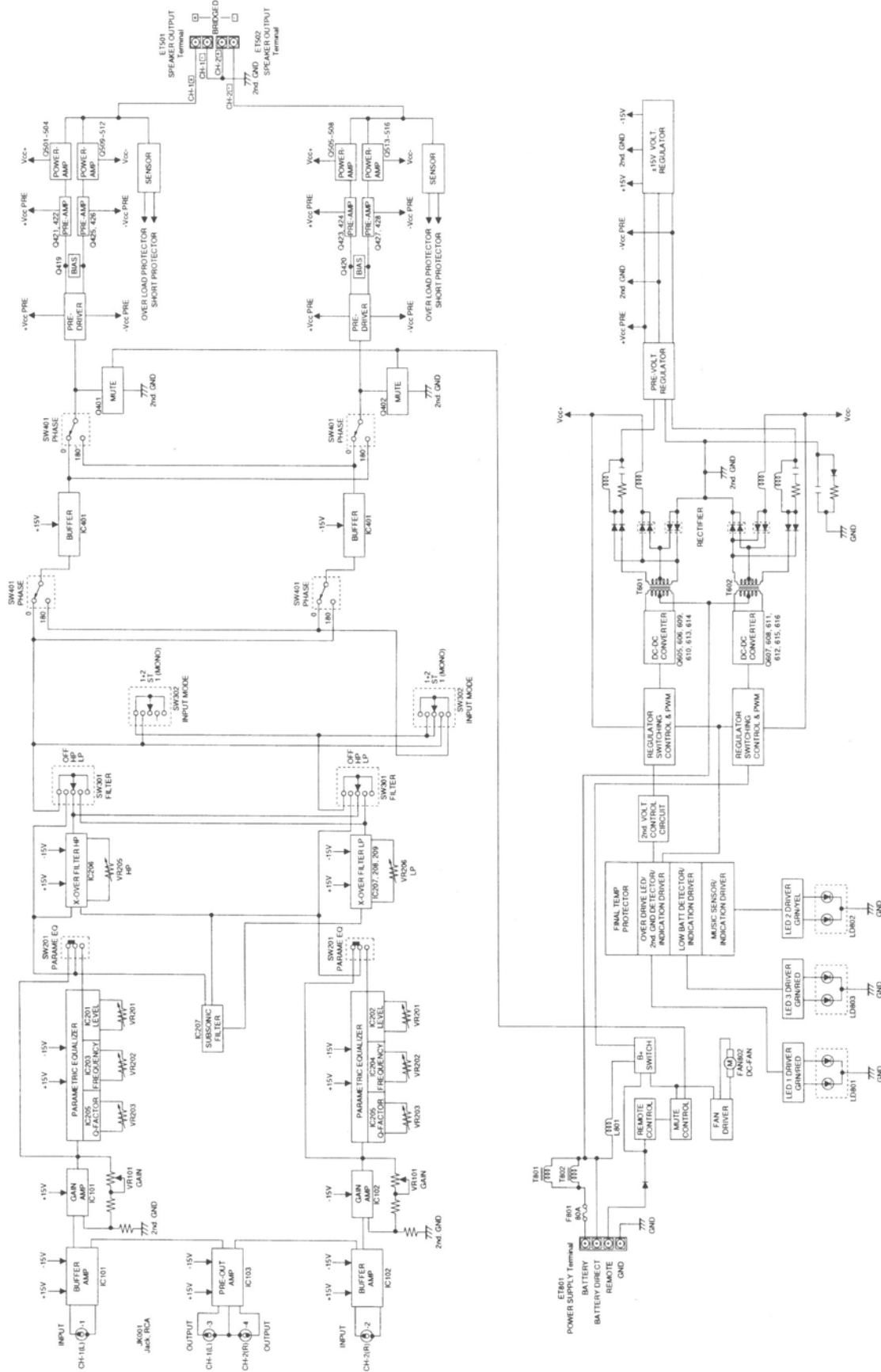

Parts Layout on P.W. Boards and Wiring Diagram (1)

Main P.W. Board

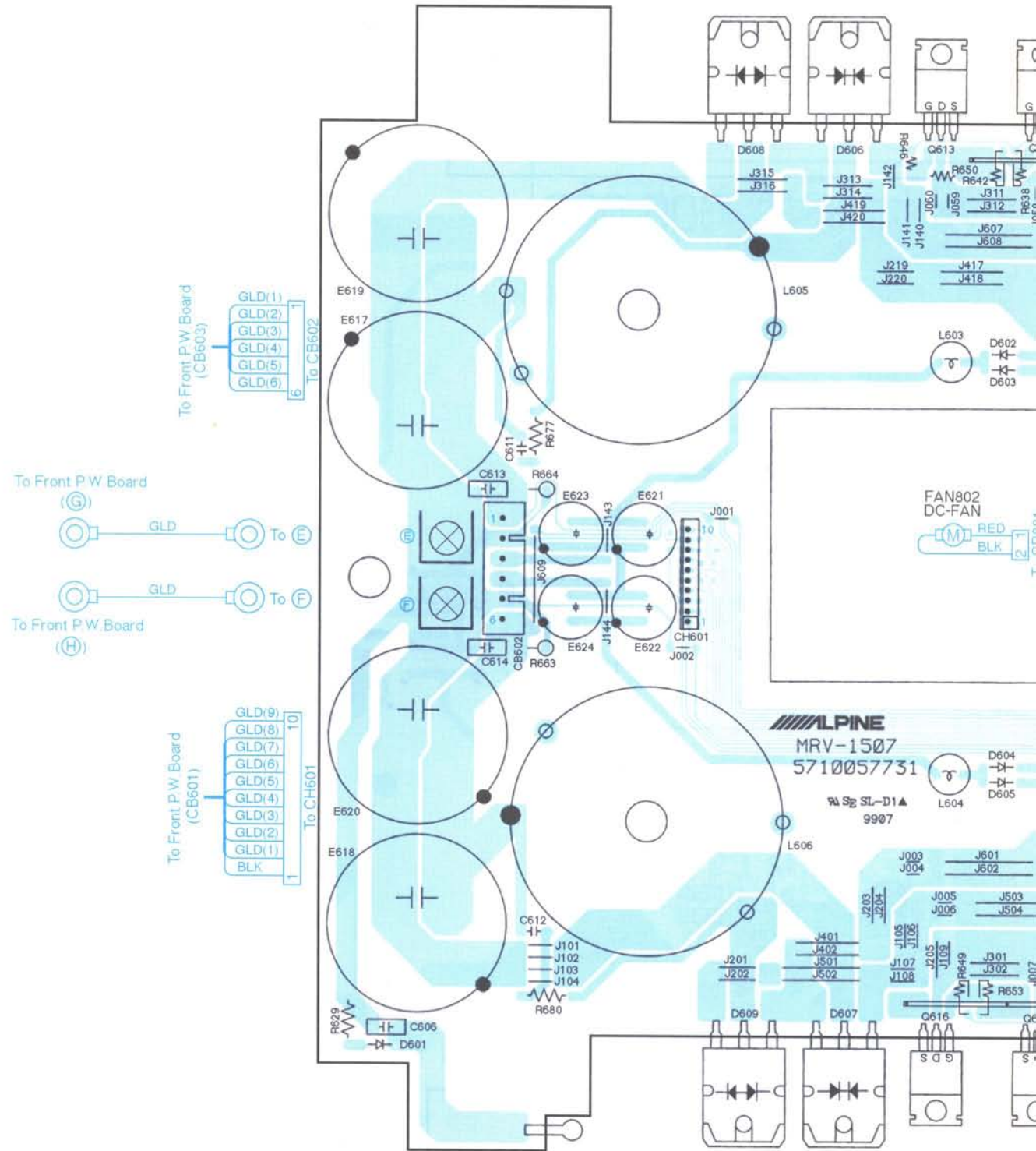

Blue Color Pattern : Foil Side Pattern

A

B - 7 -

C

D

Diagram (1/5)

Main P.W. Board (Component Side View)

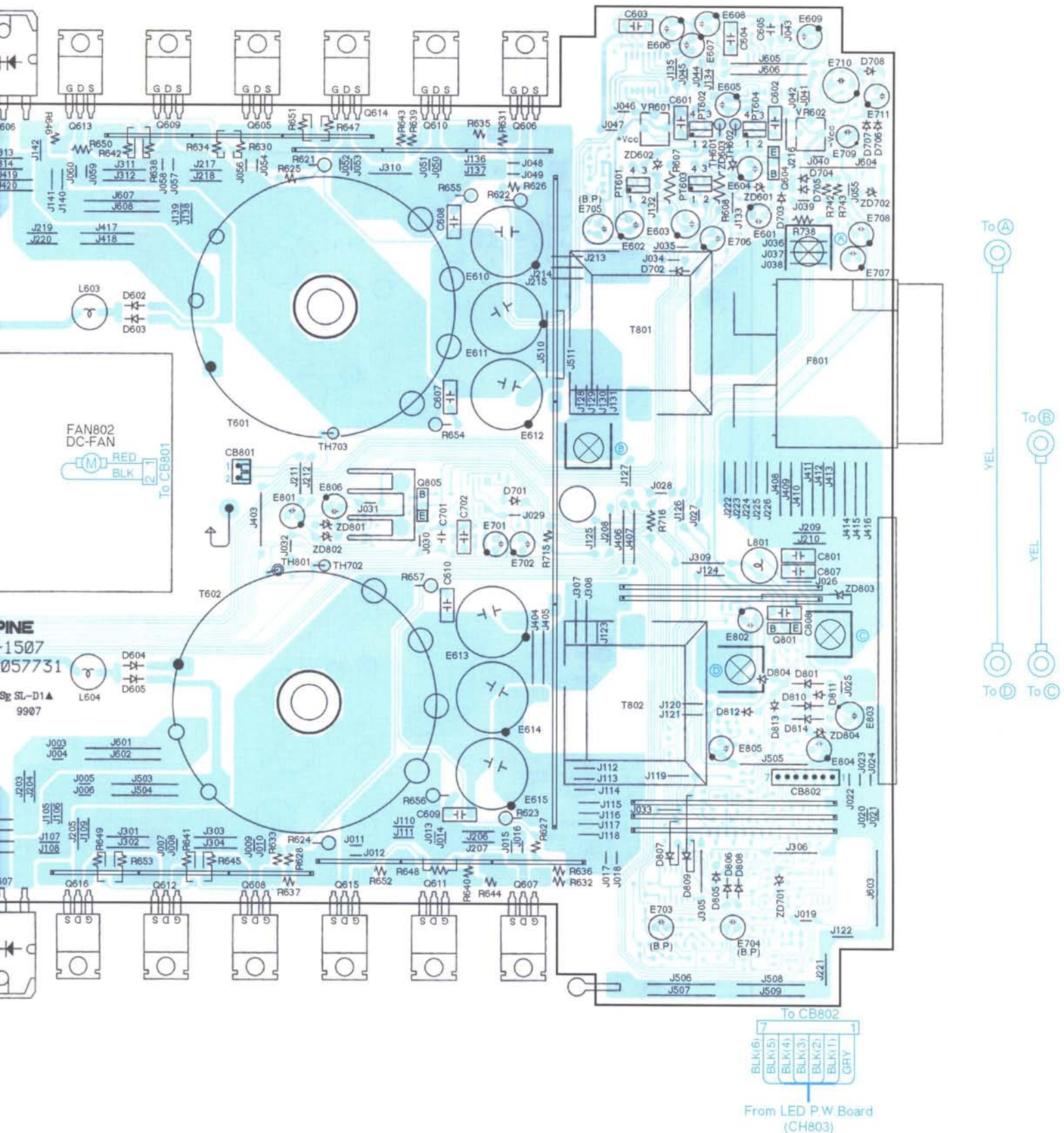

Parts Layout on P.W. Boards and Wiring Diagram (2/5)

Main P.W. Board (P



1

2

3

4

5

A

B - 9 -

C

D

P.W.Board (Foil Side View)

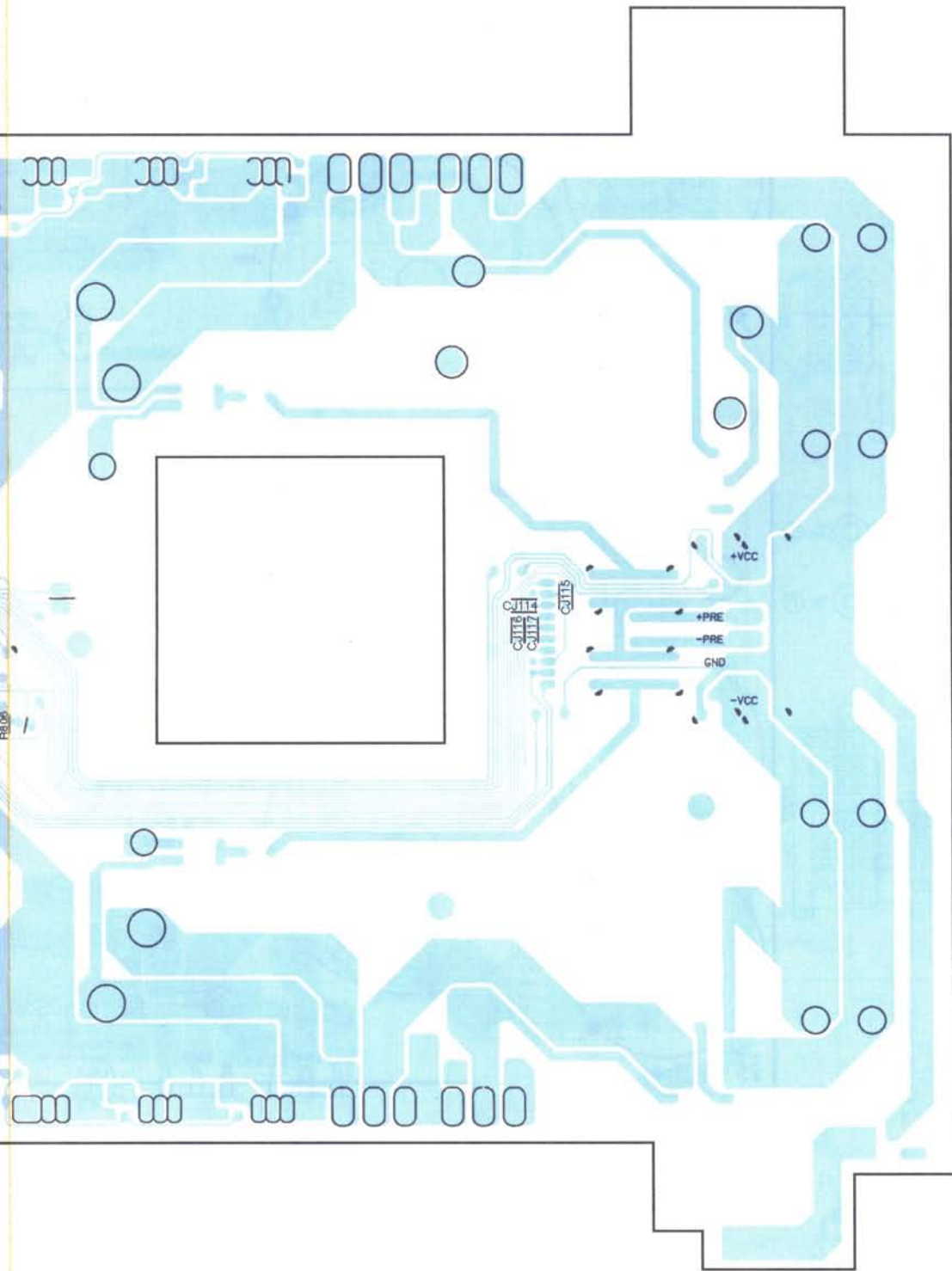

Blue Color Pattern : Foil Side Pattern

Parts Layout on P.W. Boards and Wiring Diagram (3/)

Front P.W.E

1

2

3

4

5

A

B - 11 -

C

D

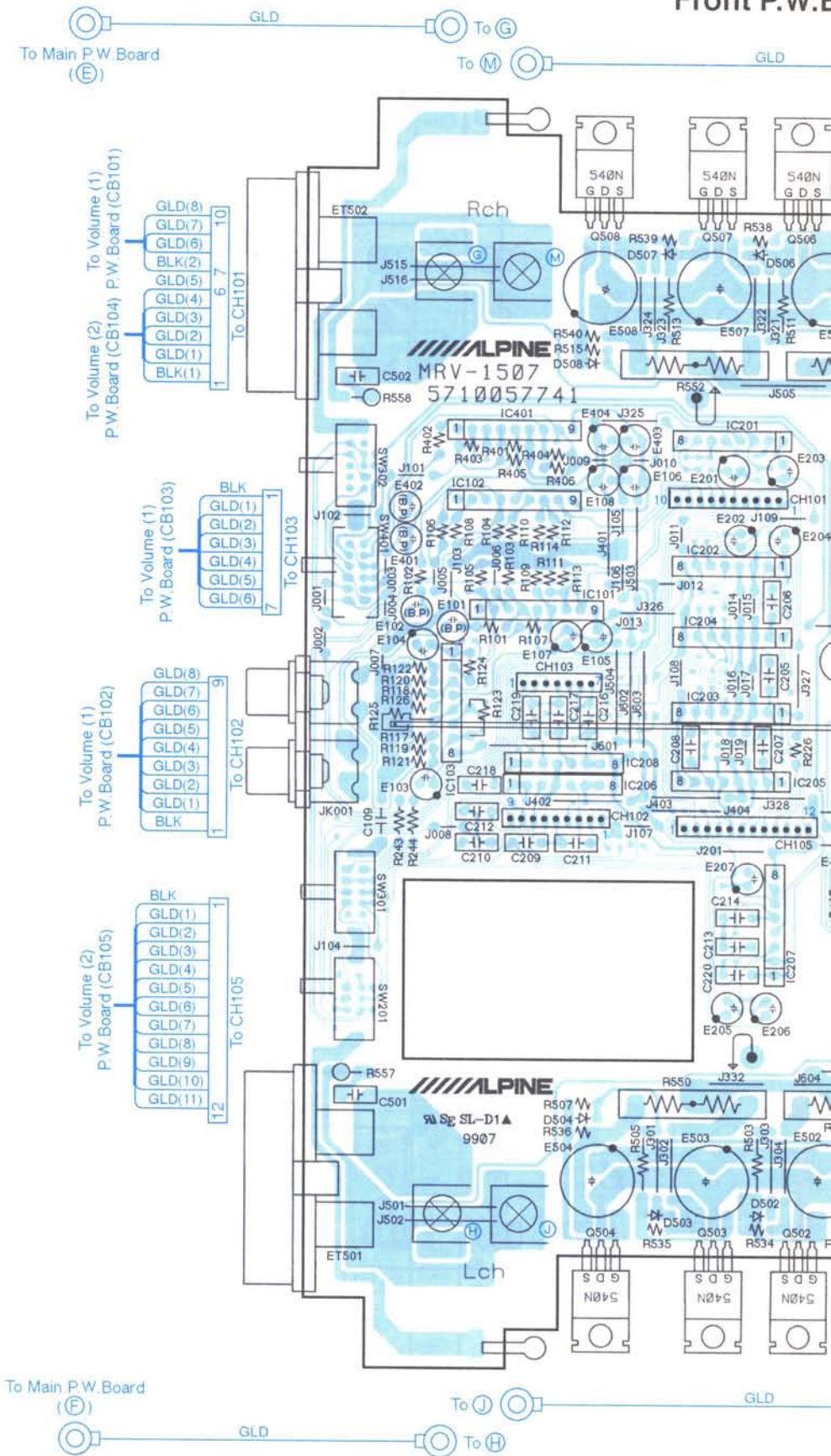

Front P.W.Board (Component Side View)

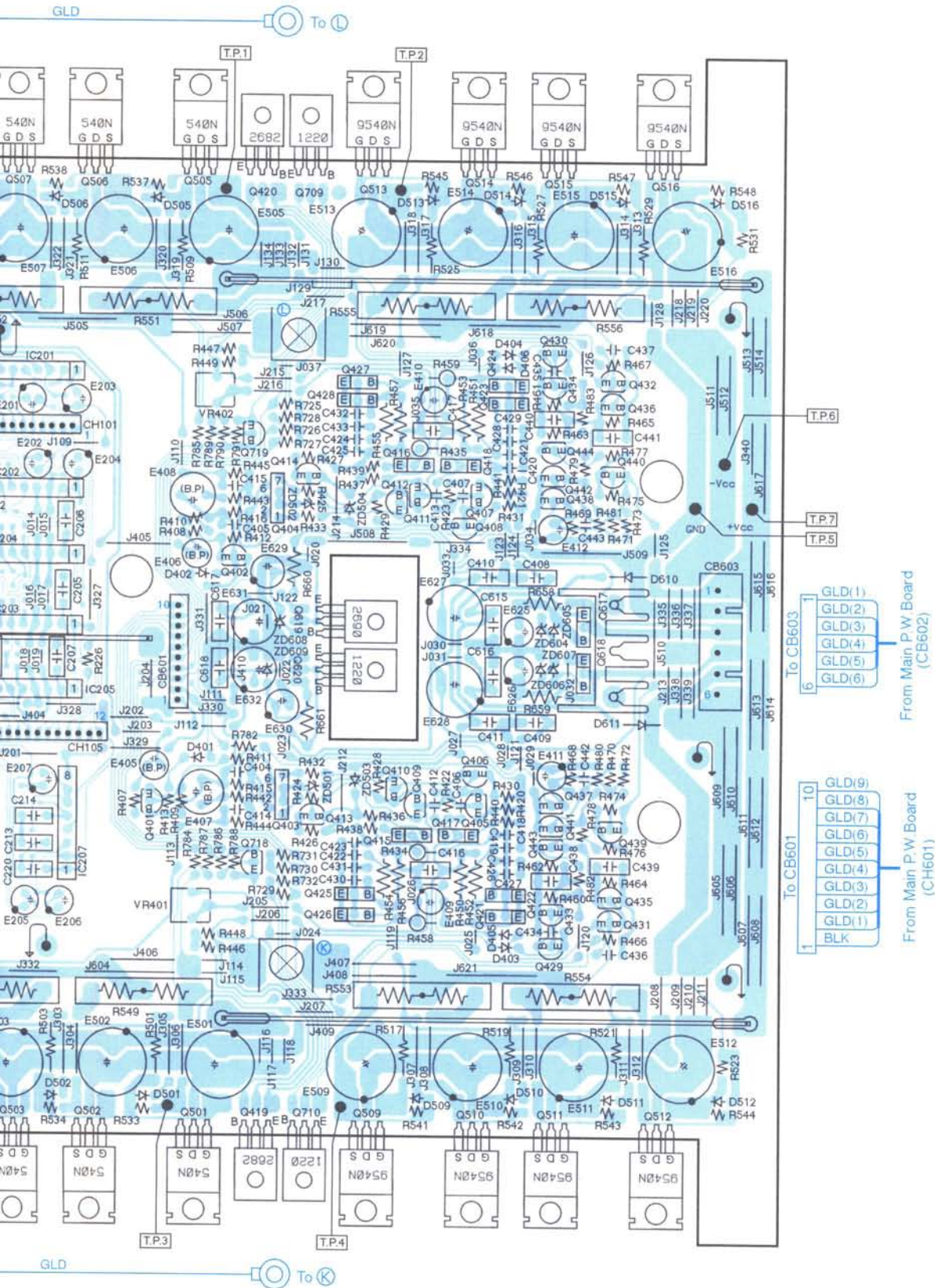

Blue Color Pattern : Foil Side Pattern

Parts Layout on P.W. Boards and Wiring Diagram (4/5)

Front P.W.Board (Foil S

1

2

3

4

5

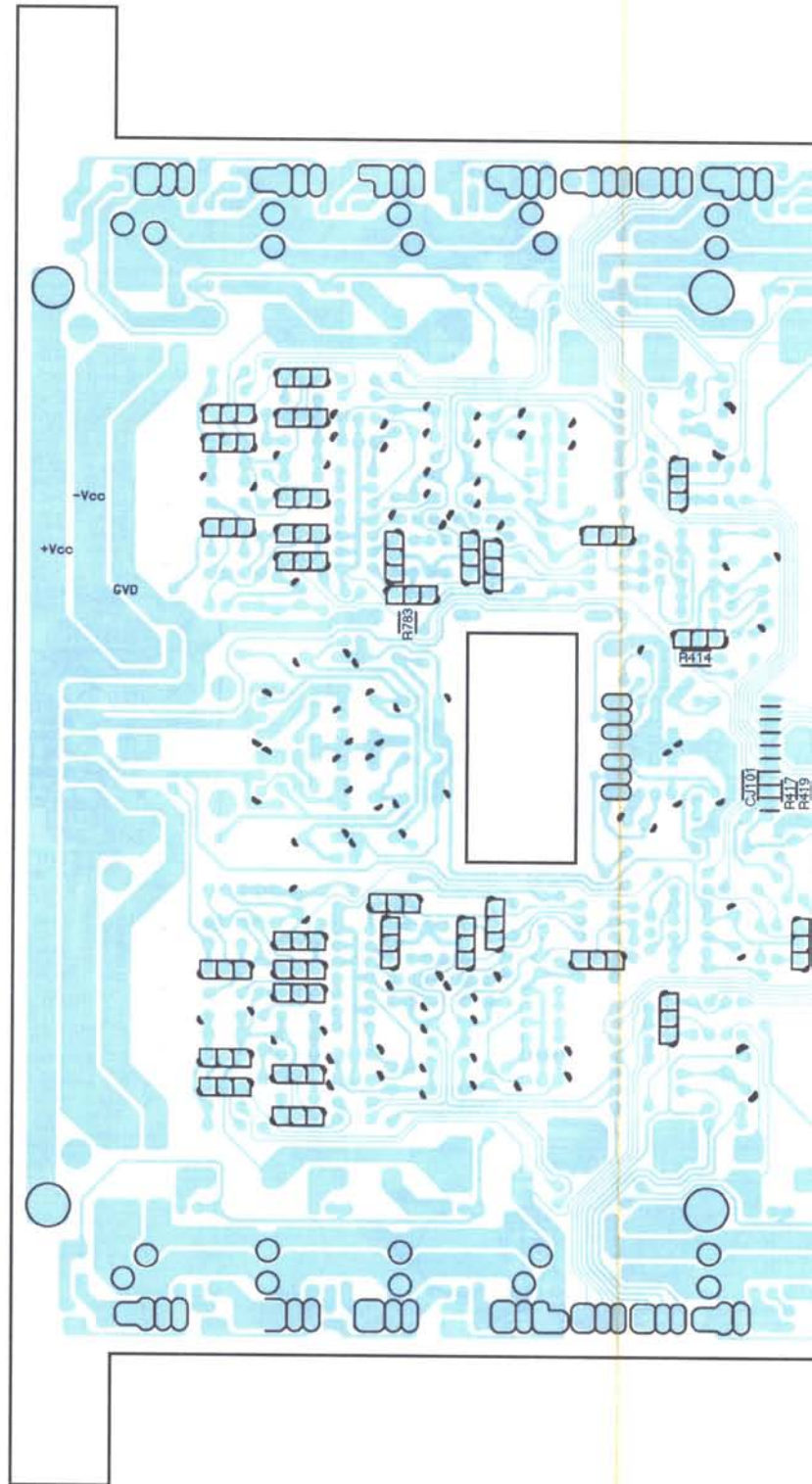

A

B - 13 -

C

D

Board (Foil Side View)

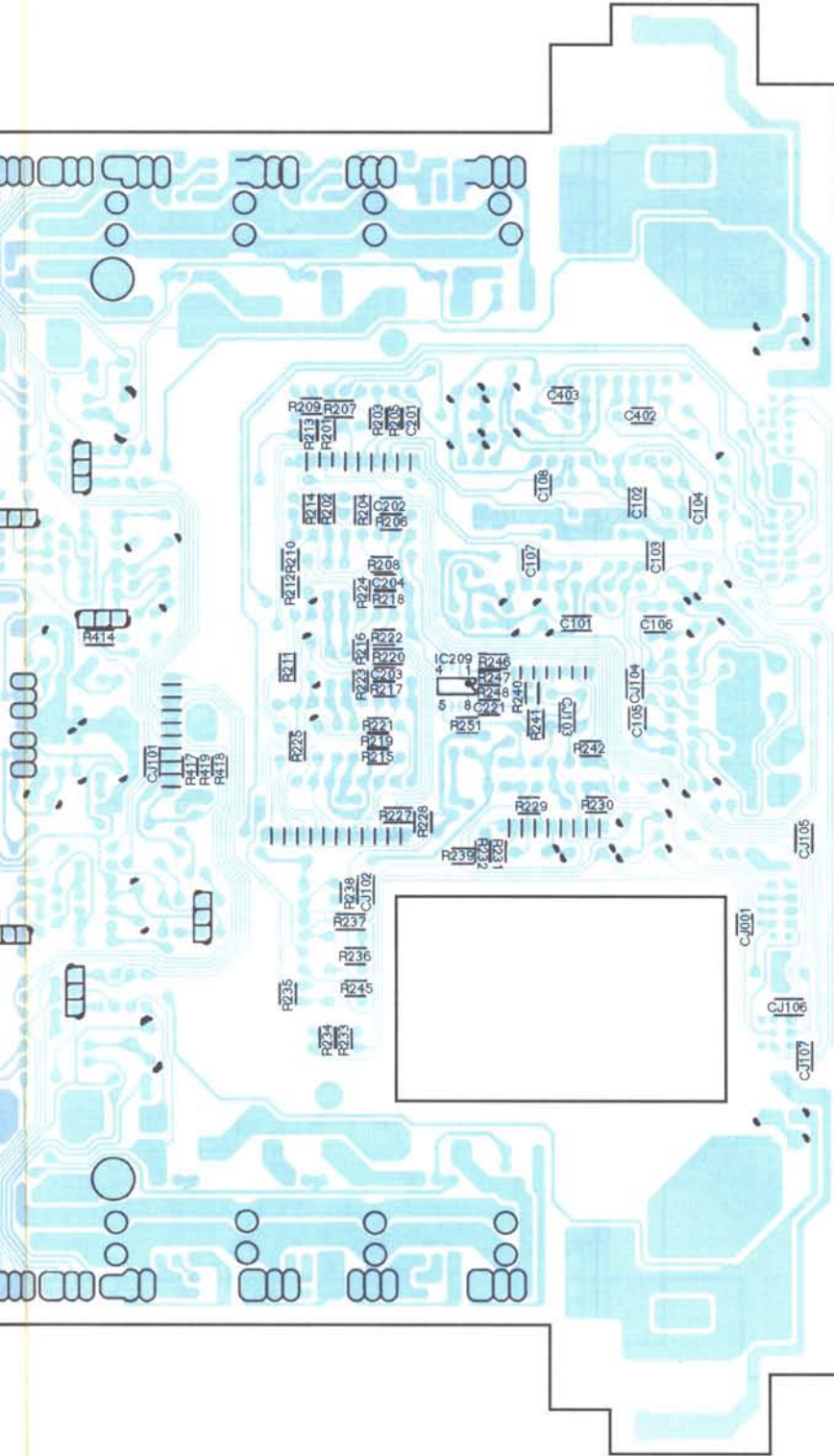

Blue Color Pattern : Foil Side Pattern

Parts Layout on P.W. Boards and Wiring Diagram (5)

1

Volume(1) P.W.Board (Component Side View)

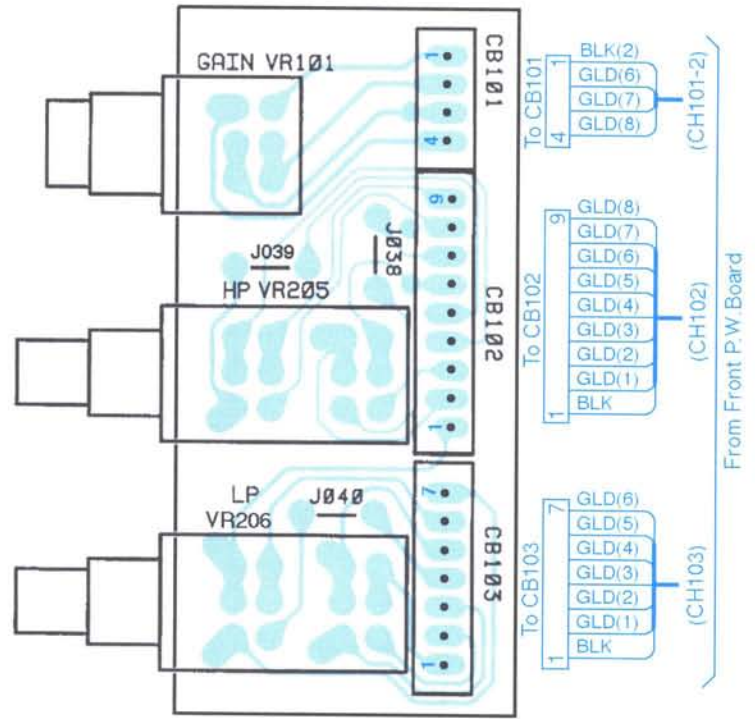

2

3

Volume(2) P.W.Board (Component Side View)

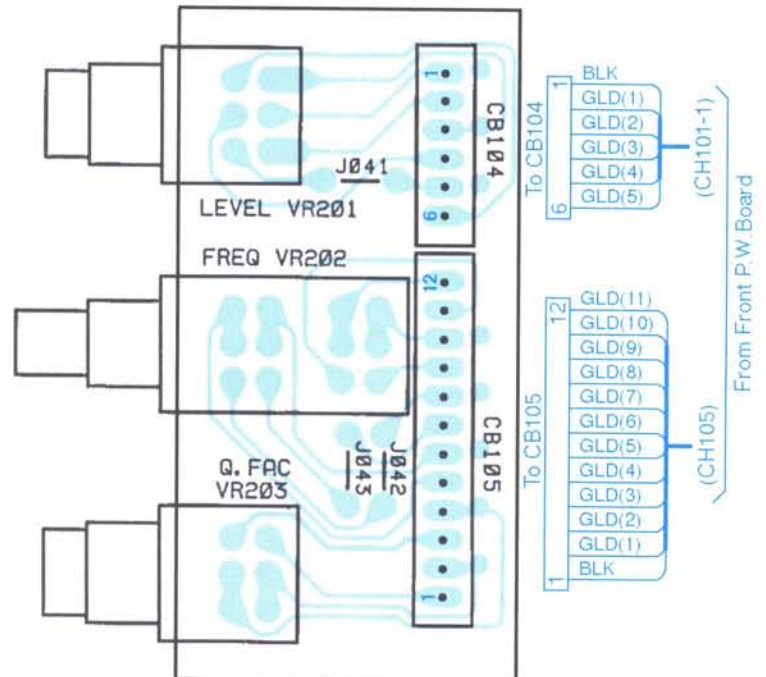

4

5

A

B - 15 -

C

D

Diagram (5/5)

From Front P.W Board

LED P.W.Board (Component Side View)

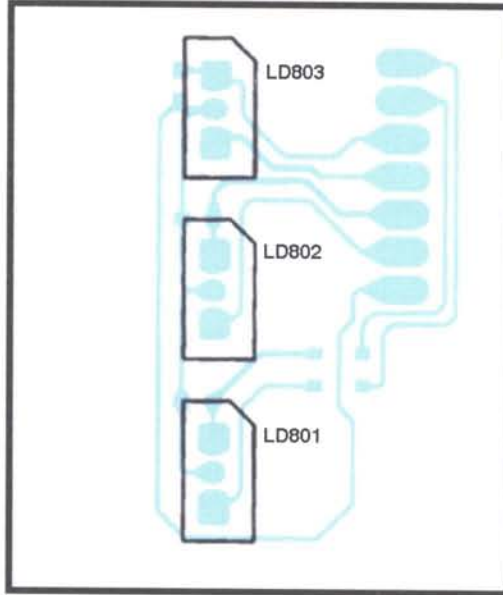

LED P.W.Board (Foil Side View)

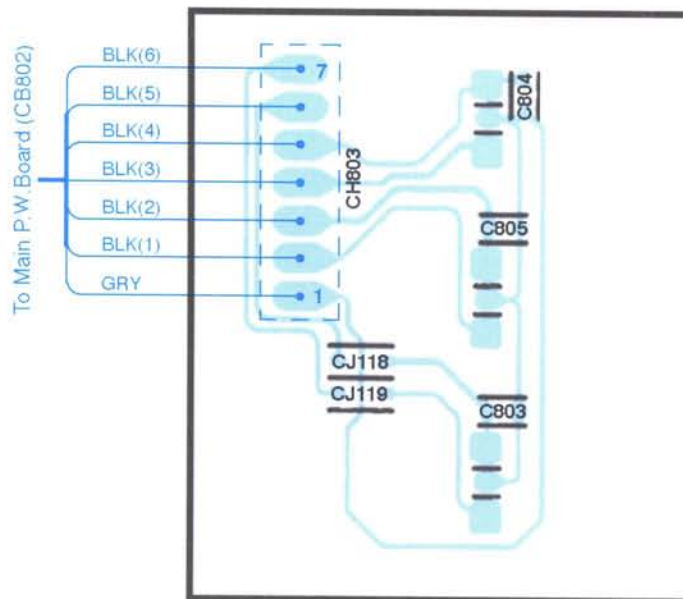

Blue Color Pattern : Foil Side Pattern

From Front P.W Board

Schematic Diagram (1/4)

1

2

3

4

5

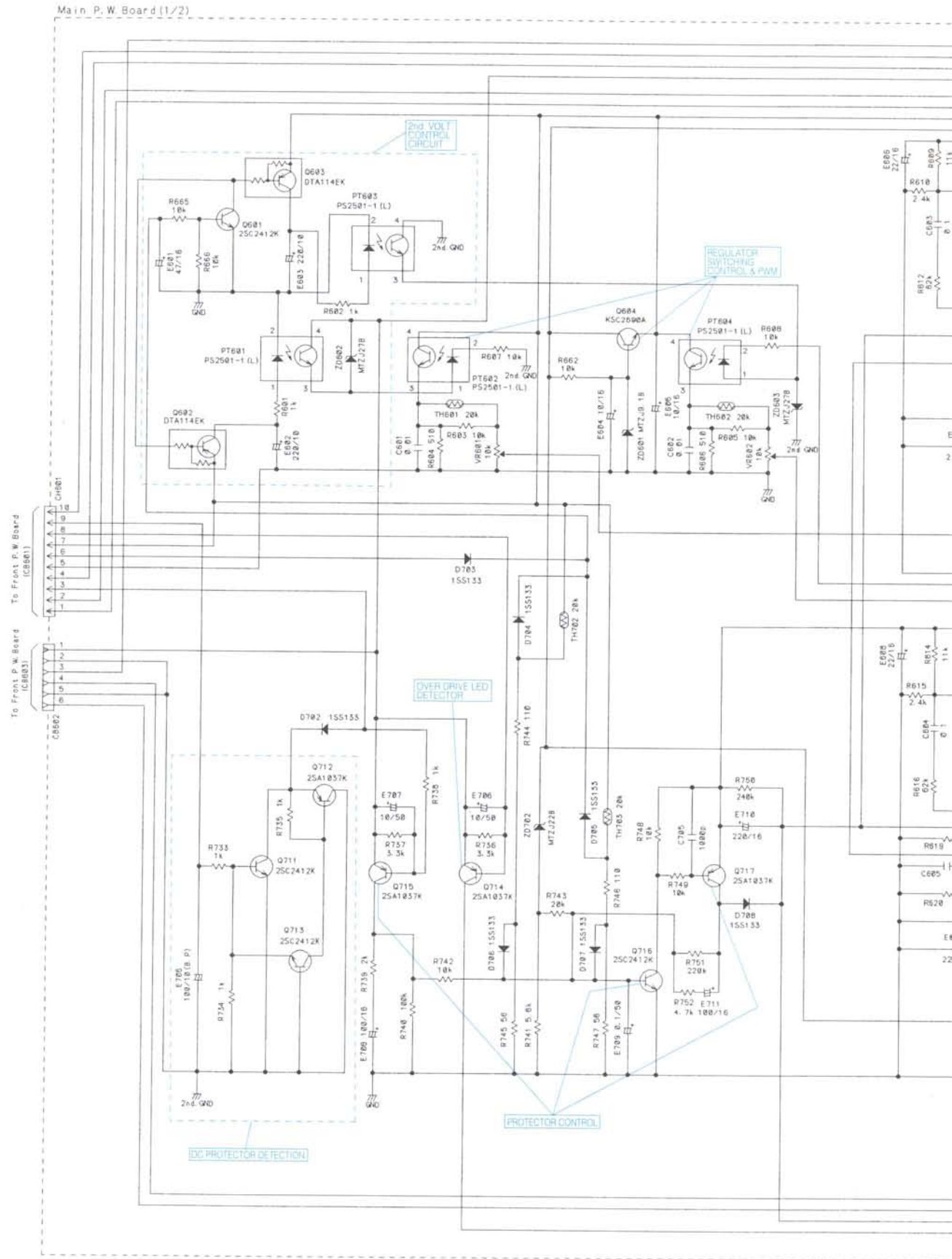

A

B -17-

C

D

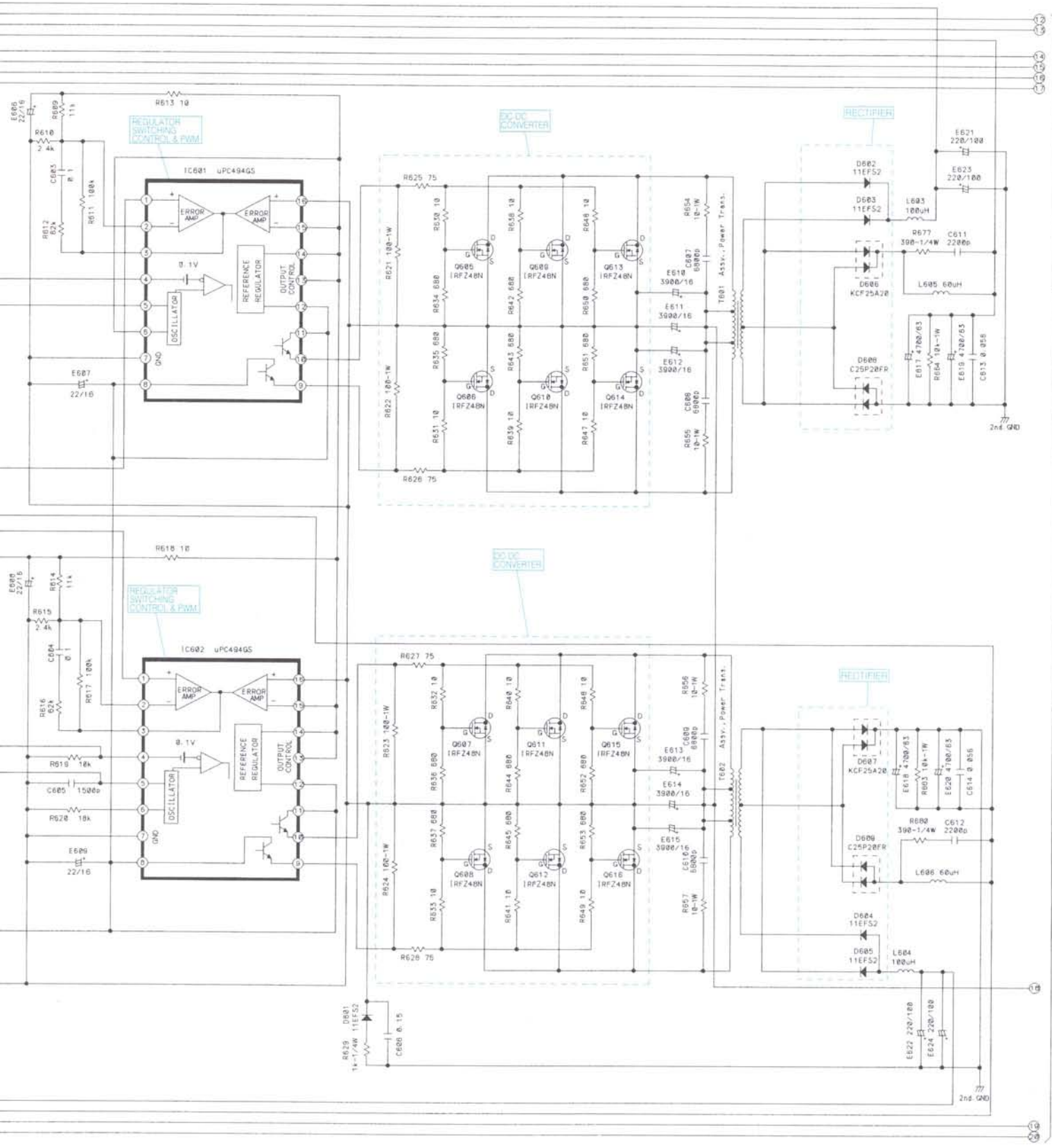

10 Main P.W. Board (2/2)

IC601

1, 2	0.9V	8	14.1V
3	2.36V	9	3.36V
4	0.2V	10	3.37V
5	1.7V	11, 12	14.1V
6	5V	13-15	5V
7	0V	16	3.6mV

IC602

1, 2	0.9V	8	14.1V
3	2.36V	9	3.24V
4	0.2V	10	3.27V
5	1.7V	11, 12	14.1V
6	4.2V	13-15	5V
7	0V	16	3mV

	G	D	S
Q605	2.24V	14.2V	0V
Q606	2.1V	14.2V	0V
Q607	2.24V	14.2V	0V
Q608	2.1V	14.2V	0V
Q609	2.24V	14.2V	0V
Q610	2.1V	14.2V	0V
Q611	2.24V	14.2V	0V
Q612	2.1V	14.2V	0V
Q613	2.24V	14.2V	0V
Q614	2.1V	14.2V	0V
Q615	2.24V	14.2V	0V
Q616	2.1V	14.2V	0V

	E	C	B
Q601	0V	8.08V	0V
Q602	8.08V	0.51V	8V
Q603	8.08V	1V	8.8V
Q604	8.1V	14.1V	8.7V
Q711	0V	49.5V	0V
Q712	48.7V	0V	48.7V
Q713	0V	48.8V	0V
Q714	49.2V	0V	49.2V
Q715	49.2V	0V	49.2V
Q716	0V	5V	0V
Q717	5V	0V	5V

[Measuring Conditions]

- Power Supply Voltage : DC14.4V
- Measuring Meter : Digital Multi Voltmeter
- Measuring Point Reference : Between Ground
- Measuring Conditions : No Signal Input

NOTE:

1. All resistance values are in ohms. $K = 1,000$
2. All capacitance values are in microfarads. $P = \frac{1}{1,000,000}$

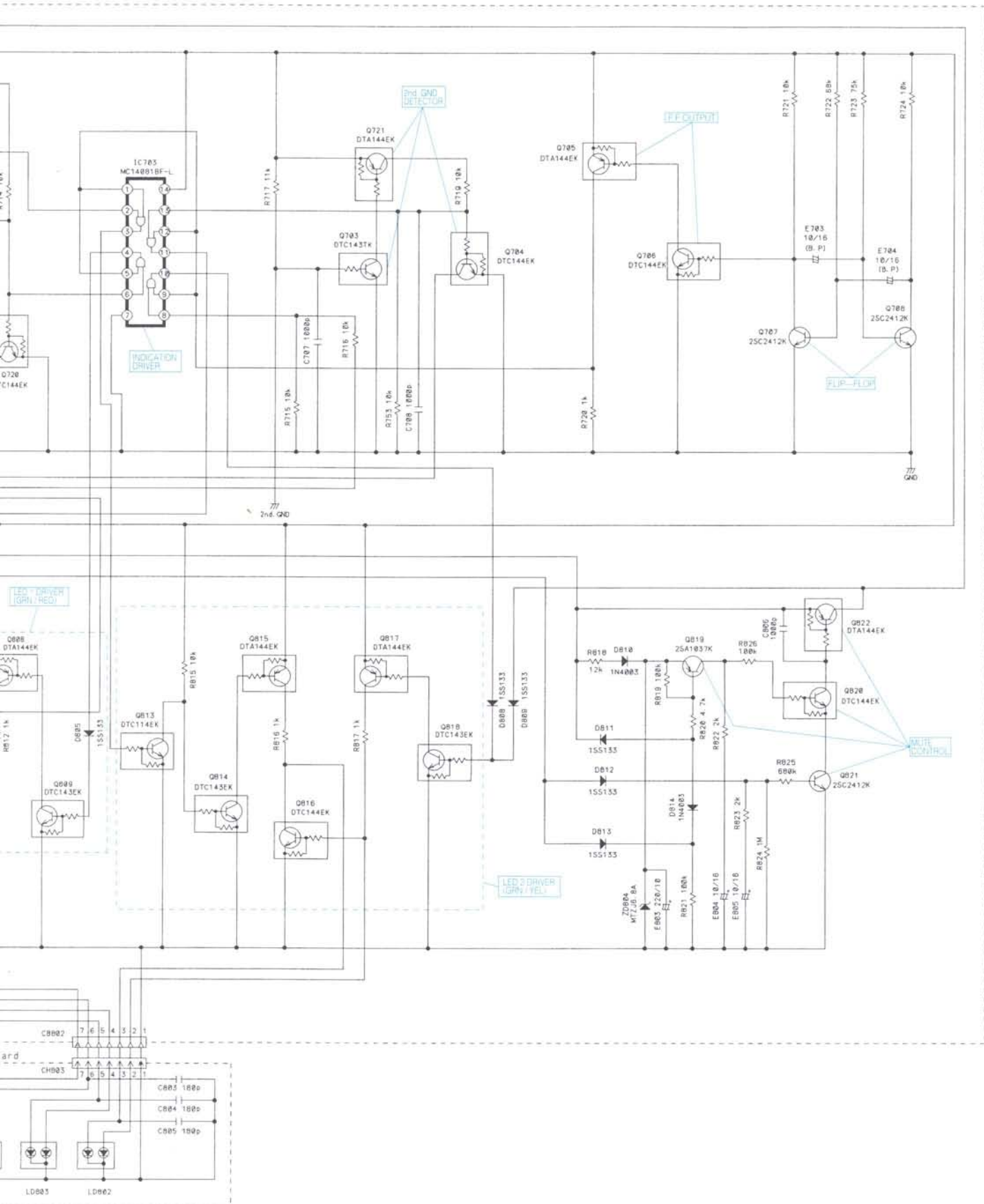

IC701

1	7.6mV
2	4.5mV
3	4V
4	8V
5	1.6mV
6	0.6V
7	3mV
8	8.5mV

IC702

1	15.5V
2	4.67V
3	7.1V
4	-15.8V
5	1.8V
6	1.5mV
7	1.8mV
8	15.9V

IC703

1	1V	8	11mV
2	7.4V	9, 10	1.7mV
3	1V	11	1.8mV
4	1.7mV	12	1V
5	1V	13	1.6mV
6	15.5mV	14	8V
7	1.6mV		

	E	C	B		E	C	B
Q701	7.96V	-0.3V	7.96V	Q807	0V	1.83V	0V
Q702	0V	0V	14.8V	Q808	8.1V	0V	8.1V
Q703	0V	0V	7.85V	Q809	0V	8.1V	0V
Q704	0V	1.87V	0V	Q810	0V	1.67V	0V
Q705	0V	0V	8V	Q811	8.1V	0V	8.1V
Q706	0V	0V	0V	Q812	0V	8.1V	0V
Q707	0V	0.1V	0.26V	Q813	0V	3V	0V
Q708	0V	0V	0V	Q814	0V	0V	3.02V
Q720	0V	1.84V	0V	Q815	8V	1.75V	0V
Q721	8V	0V	8V	Q816	0V	2V	0V
Q801	14.3V	14.1V	13.1V	Q817	8.1V	0V	8.1V
Q802	0V	2.67V	43.5mV	Q818	0V	8.1V	0V
Q803	0V	1.2V	0V	Q819	6.3V	6V	0V
Q804	8.83V	8.76V	0V	Q820	0V	0V	13.2V
Q805	9.1V	14.3V	8.84V	Q821	0V	0V	0.55V
Q806	14.3V	0V	14.3V	Q822	14.4V	-7.8V	14.3V

[Measuring Conditions]

- Power Supply Voltage : DC14.4V
- Measuring Meter : Digital Multi Voltmeter
- Measuring Point Reference : Between Ground
- Measuring Conditions : No Signal Input

NOTE:

1. All resistance values are in ohms. $K = 1,000$
2. All capacitance values are in microfarads. $P = \frac{1}{1,000,000}$

Schematic Diagram (3/4)

1

2

3

4

5

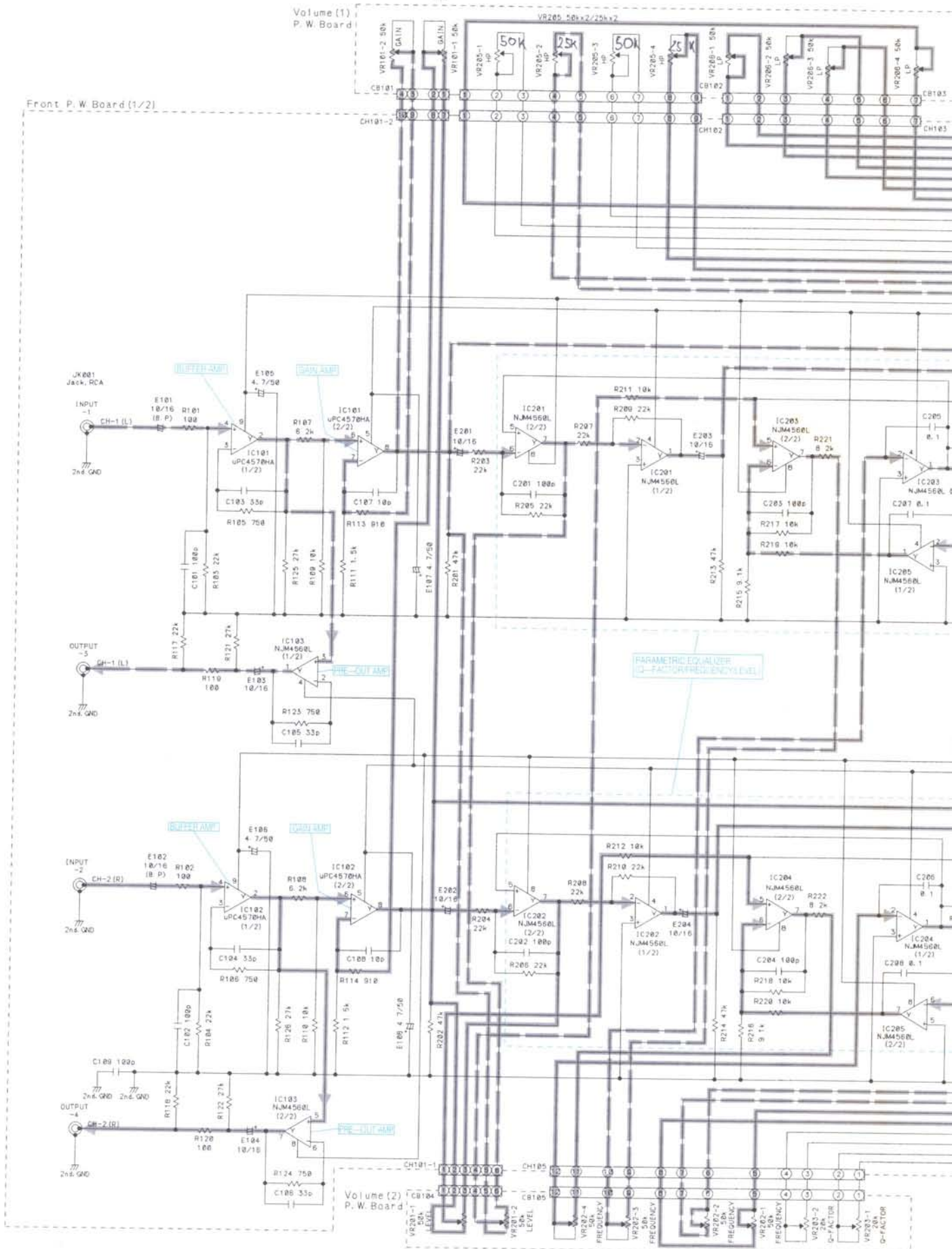

A

B - 23 -

C

D

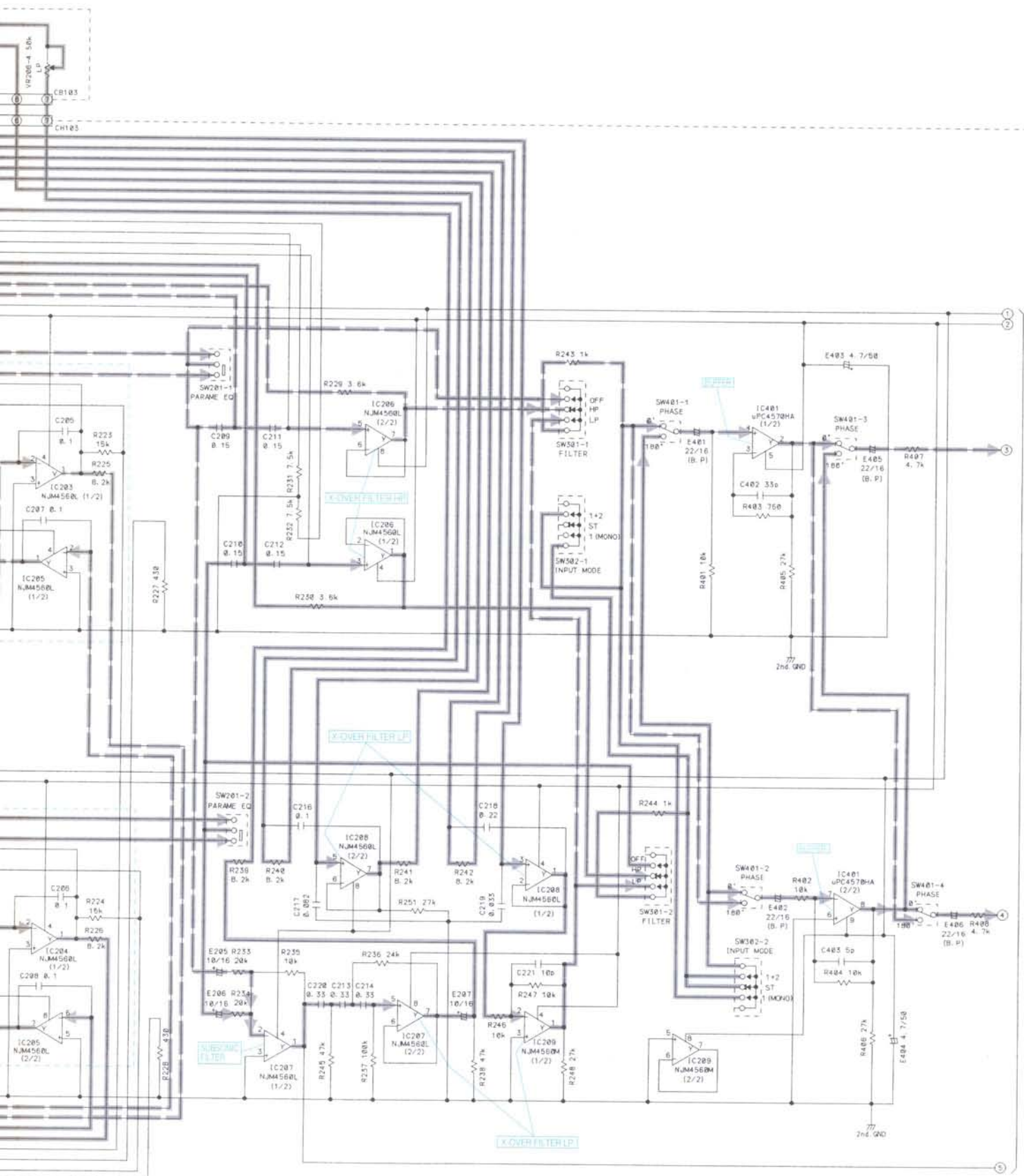

To Front P.W. Board(2/2)

IC101		IC102		IC103		IC201		IC202	
1	NC	1	NC	1, 2	2.5mV	1	1.6mV	1	0V
2, 3	1.7mV	2, 3	1.9mV	3	1.9mV	2	8.1mV	2	9.4mV
4	1.3mV	4	1.2mV	4	-15.4V	3	0V	3	0V
5	-15.2V	5	-15.3V	5	1.6mV	4	-15.5V	4	-15.6V
6	1.2mV	6	1.3mV	6	1.9mV	5	1.2mV	5-7	0V
7	1.6mV	7	1.9mV	7	2mV	6	0V	8	15.8V
8	10.5mV	8	13.7mV	8	15.7V	7	1.6mV		
9	15.6V	9	15.6V			8	15.8V		

IC203		IC204		IC205		IC206		IC207	
1-3	0V	1-3	0V	1	4.8mV	1-3	0V	1	0V
4	-15.4V	4	-15.4V	2, 3	0V	4	-15.6V	2	5.3mV
5	0V	5	0V	4	-15.5V	5	0V	3	0V
6	1.5mV	6	1.7mV	5, 6	0V	6	1.8mV	4	-15.6V
7	0V	7	0V	7	4.5mV	7	0V	5	4.2mV
8	15.7V	8	15.7V	8	15.8V	8	15.8V	6, 7	4.8mV
								8	15.8V

IC208		IC209		IC401	
1-3	5.4mV	1	6.2mV	1	NC
4	-15.6V	2	13.1mV	2, 3	1.1mV
5	2.8mV	3	5.9mV	4	0V
6, 7	3.4mV	4	-15.8V	5	-15.5V
8	15.7V	5-7	0V	6-8	0V
		8	15.7V	9	15.8V

[Measuring Conditions]

- Power Supply Voltage : DC14.4V
- Measuring Meter : Digital Multi Voltmeter
- Measuring Point Reference : Between Ground
- Measuring Conditions : No Signal Input

NOTE:

1. All resistance values are in ohms. $K = 1,000$
2. All capacitance values are in microfarads. $P = \frac{1}{1,000,000}$

Schematic Diagram (4/4)

1

Front P.W. Board (2/2)

2

3

4

5

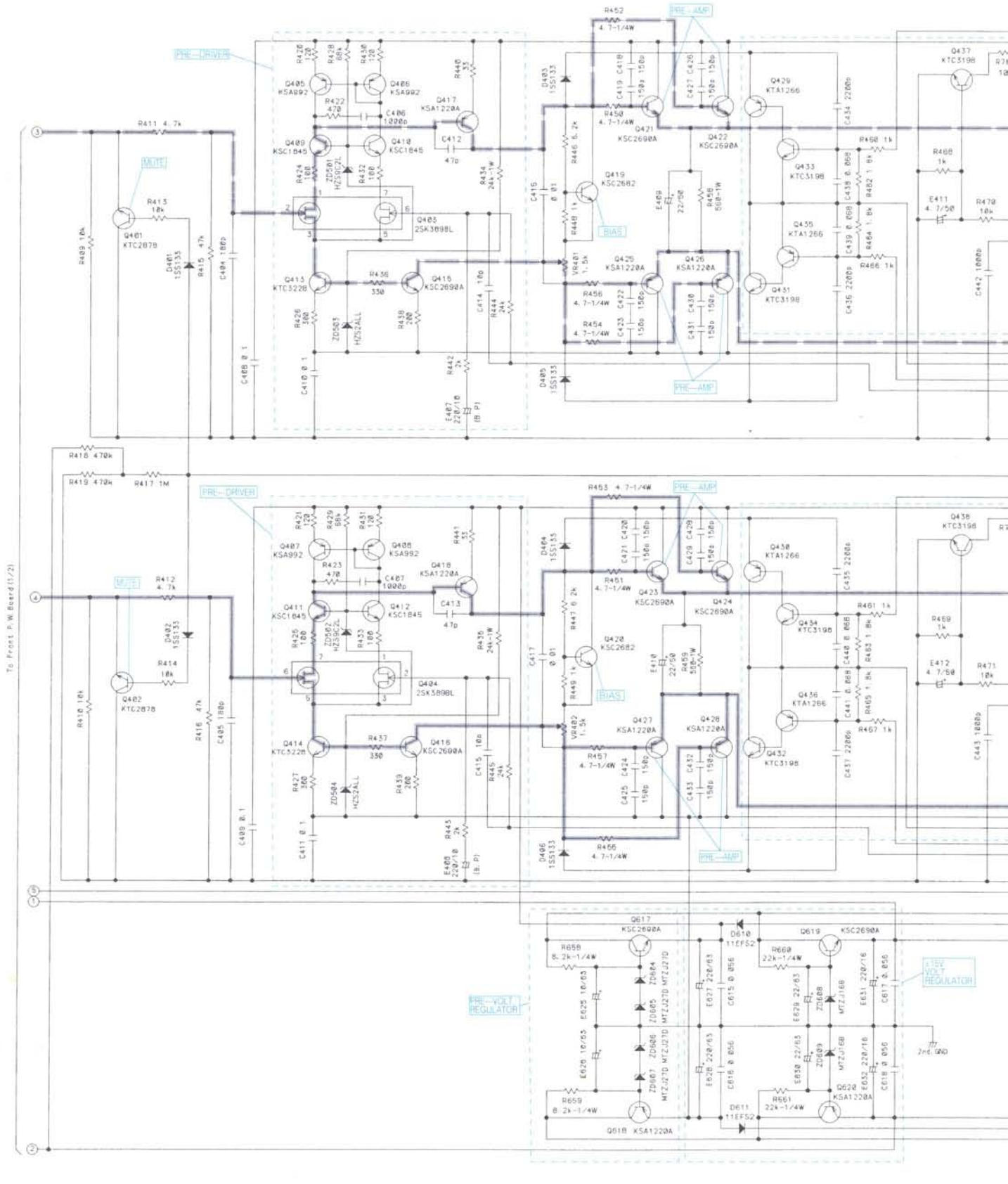

A

B - 26 -

C

D

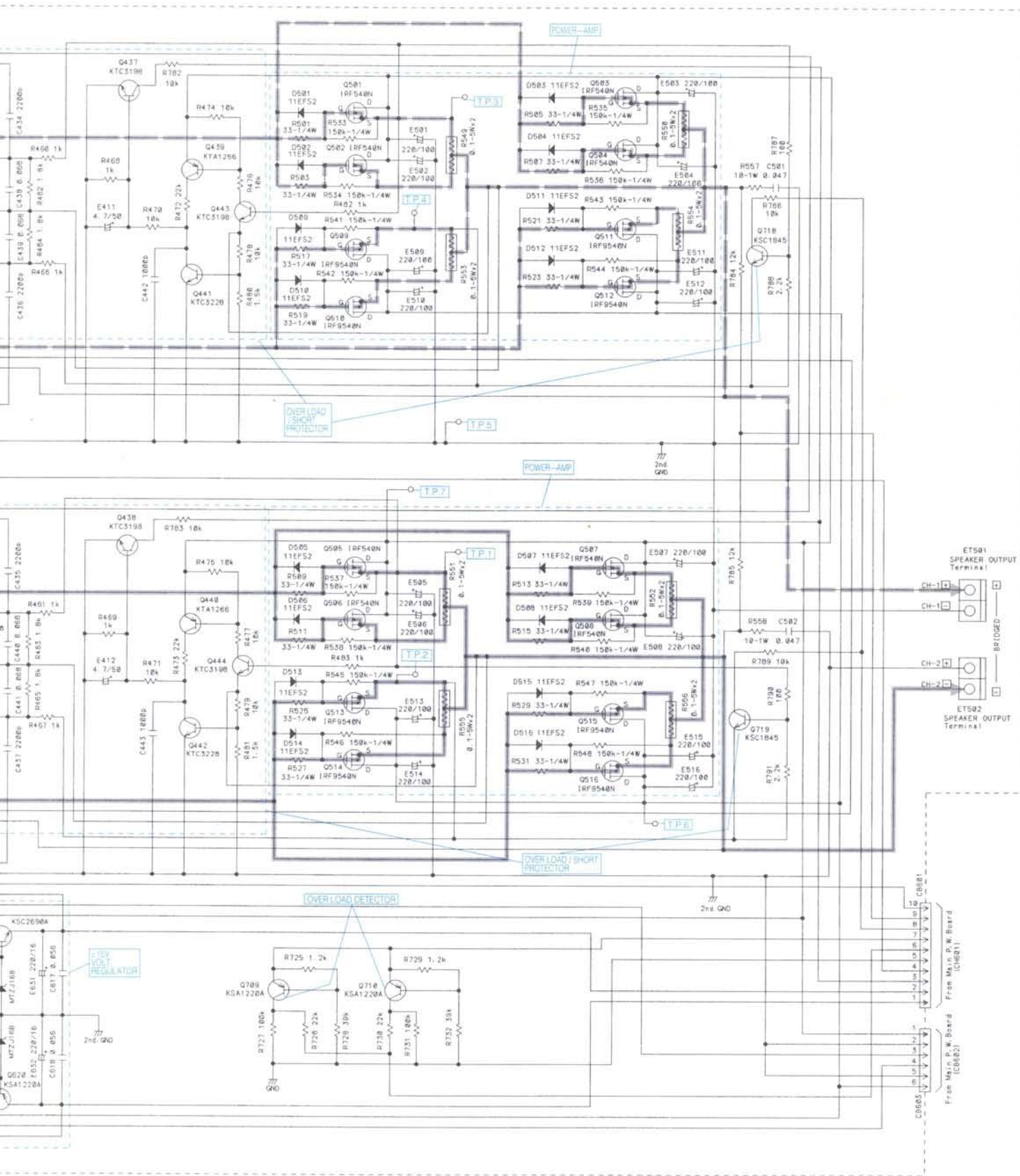

D

E

- 27 -

F

G

H

	G	D	S		G	D	S
Q501	3V	49.1V	0V	Q509	-3.4V	-49.4V	0V
Q502	3V	49.1V	0V	Q510	-3.4V	-49.4V	0V
Q503	3V	49.1V	0V	Q511	-3.4V	-49.4V	0V
Q504	3V	49.1V	0V	Q512	-3.4V	-49.4V	0V
Q505	2.8V	48.8V	0V	Q513	-3.5V	-49.1V	0V
Q506	2.8V	48.8V	0V	Q514	-3.5V	-49.1V	0V
Q507	2.8V	48.8V	0V	Q515	-3.5V	-49.1V	0V
Q508	2.8V	48.8V	0V	Q516	-3.5V	-49.1V	0V

	1	2	3	4	5	6	7
Q403	8.87V	0V	0.38V	NC	0.38V	0V	8.7V
Q404	8.79V	0V	0.29V	NC	0.29V	0V	8.7V

	E	C	B		E	C	B		E	C	B
Q401	0V	0V	0V	Q420	-0.5V	3.57V	0.14V	Q437	0V	48.9V	0V
Q402	0V	0V	0V	Q421	3V	53.8V	3.54V	Q438	0V	48.9V	0V
Q405	53.4V	52.7V	53V	Q422	3V	53.8V	3.54V	Q439	48.9V	0V	48.9V
Q406	53.4V	52.6V	52.9V	Q423	3.4V	53.8V	3.9V	Q440	48.9V	0V	48.9V
Q407	53.6V	53.1V	53.3V	Q424	3.4V	53.8V	3.9V	Q441	0V	0V	0V
Q408	53.6V	53.2V	53.1V	Q425	-3.4V	-54.2V	-3.84V	Q442	0V	0V	0V
Q409	9.1V	49.1V	9.7V	Q426	-3.4V	-54.2V	-3.84V	Q443	0V	48.9V	0V
Q410	9.1V	49.1V	9.7V	Q427	-3.4V	-54.2V	-3.84V	Q444	0V	48.9V	0V
Q411	9.2V	49.3V	9.8V	Q428	-3.6V	-54.2V	-4V	Q617	53.2V	60.6V	53.9V
Q412	9.1V	49.1V	9.8V	Q429	4.7V	0V	4.7V	Q618	-54V	-60.9V	-54.7V
Q413	-52.6V	0.38V	-52.2V	Q430	4.86V	0V	4.95V	Q619	15.5V	60.2V	16V
Q414	-52.2V	0.29V	-52.5V	Q431	-4.8V	0V	-4.8V	Q620	-15.7V	-60.4V	-16.1V
Q415	-52.4V	-3.98V	-51.9V	Q432	-5V	0V	-5V	Q709	8.1V	0V	7.85V
Q416	-52.6V	-3.9V	-52.2V	Q433	0V	4.7V	0V	Q710	8.1V	0V	7.85V
Q417	53.1V	3.9V	52.8V	Q434	0V	4.5V	0V	Q718	0V	49.1V	0V
Q418	53.4V	3.59V	53V	Q435	0V	-4.4V	0V	Q719	0V	49.1V	0V
Q419	-0.4V	3.59V	0.16V	Q436	0V	-4.5V	0V				

[Measuring Conditions]

- Power Supply Voltage : DC14.4V
- Measuring Meter : Digital Multi Voltmeter
- Measuring Point Reference : Between Ground
- Measuring Conditions : No Signal Input

NOTE:

1. All resistance values are in ohms. K = 1,000
2. All capacitance values are in microfarads. P = $\frac{1}{1,000,000}$

Electrical Parts List

Capacitor : μ F=microfarads,pF=picofarads

Abbreviations			Symbol No.	Part No.	Description
RES.= Resistor	CAP.= Capacitor		Q713	48E22902S01	TR,2SC2412K-Q,R,S-T146-CP BR
C.F.= Carbon Film	ELY.= Electrolytic		Q714	48E22900S01	TR,2SA1037K-Q,R,S-CP FQ
M.F.= Metal Film	CER.= Ceramic		Q715	48E22900S01	TR,2SA1037K-Q,R,S-CP FQ
M.O.= Metal Oxide Film	MYL.= Mylar		Q716	48E22902S01	TR,2SC2412K-Q,R,S-T146-CP BR DS
M.P.= Metal Plate	TAN.= Tantalum		Q717	48E22900S01	TR,2SA1037K-Q,R,S-CP FQ FR
TR. = Transistor	POLY.= Polystyrol		Q720	48E22555S01	TR,DTC144EK-T-146-CP 26
TRANS.= Transformer	PP. = Polypropylene		Q721	48E23697S01	TR,DTA144EK-T-146-CP 16
CP. = Chip	PLT.= Polyethylene		Q801	48E05943S01	TR,KSA 1220A-Y
	PF. = Polyester Film		Q802	48E22903S01	TR,DTC143EK-T-146-CP 03
			Q803	48E29514S01	TR,DTC143TK-T-146-CP 03
Symbol No.	Part No.	Description	Q804	48E23697S01	TR,DTA144EK-T-146-CP 16
Main P.W.Board			Q805	48E10027S01	TR,KSC 2690A-Y
IC's			Q806	48E22900S01	TR,2SA1037K-Q,R,S-CP FQ
IC601	51E27890S01	IC, μ PC494GS	Q807	48E22555S01	TR,DTC144EK-T-146-CP 26
IC602	51E27890S01	IC, μ PC494GS	Q808	48E23697S01	TR,DTA144EK-T-146-CP 16
IC701	51E29513S01	BA3703F	Q809	48E22903S01	TR,DTC143EK-T-146-CP 03
IC702	51E22130S01	IC,NJM 4560M-TE3	Q810	48E22555S01	TR,DTC144EK-T-146-CP 26
IC703	51T25386Y01	MC14081BF-L	Q811	48E23697S01	TR,DTA144EK-T-146-CP 16
Transistors/FET's			Q812	48E22903S01	TR,DTC143EK-T-146-CP 03
Q601	48E22902S01	TR,2SC2412K-Q,R,S-T146-CP DR	Q813	48E22093S01	TR,DTC114EK-T-146-CP 26
Q602	48E22901S01	TR,DTA114EK-T-146-CP 14	Q814	48E22903S01	TR,DTC143EK-T-146-CP 03
Q603	48E22901S01	TR,DTA114EK-T-146-CP 14	Q815	48E23697S01	TR,DTA144EK-T-146-CP 16
Q604	48E10027S01	TR,KSC 2690A-Y	Q816	48E22555S01	TR,DTC144EK-T-146-CP 26
Q605	48T25206Y02	FET,IRFZ 248N	Q817	48E23697S01	TR,DTA144EK-T-146-CP 16
Q606	48T25206Y02	FET,IRFZ 248N	Q818	48E22903S01	TR,DTC143EK-T-146-CP 03
Q607	48T25206Y02	FET,IRFZ 248N	Q819	48E22900S01	TR,2SA1037K-Q,R,S-CP FQ
Q608	48T25206Y02	FET,IRFZ 248N	Q820	48E22555S01	TR,DTC144EK-T-146-CP 26
Q609	48T25206Y02	FET,IRFZ 248N	Q821	48E22902S01	TR,2SC2412K-Q,R,S-T146-CP DR
Q610	48T25206Y02	FET,IRFZ 248N	Q822	48E23697S01	TR,DTA144EK-T-146-CP 16
Q611	48T25206Y02	FET,IRFZ 248N	Diodes		
Q612	48T25206Y02	FET,IRFZ 248N	D601	48E25517S01	DIO,11EFS2
Q613	48T25206Y02	FET,IRFZ 248N	D602	48E25517S01	DIO,11EFS2
Q614	48T25206Y02	FET,IRFZ 248N	D603	48E25517S01	DIO,11EFS2
Q615	48T25206Y02	FET,IRFZ 248N	D604	48E25517S01	DIO,11EFS2
Q616	48T25206Y02	FET,IRFZ 248N	D605	48E25517S01	DIO,11EFS2
Q701	48E23697S01	TR,DTA144EK-T-146-CP 16	D606	48T25235Y01	DIO,KCF25A20
Q702	48E10426S01	TR,DTC124EK-T-146-CP 25	D607	48T25235Y01	DIO,KCF25A20
Q703	48E29514S01	TR,DTC143TK-T-146-CP 03	D608	48T25236Y01	DIO,C25P20FR
Q704	48E22555S01	TR,DTC144EK-T-146-CP 26	D609	48T25236Y01	DIO,C25P20FR
Q705	48E23697S01	TR,DTA144EK-T-146-CP 16	D701	48E22916S01	DIO,1SS133-T-77 -AX
Q706	48E22555S01	TR,DTC144EK-T-146-CP 26	D702	48E22916S01	DIO,1SS133-T-77 -AX
Q707	48E22902S01	TR,2SC2412K-Q,R,S-T146-CP BR	D703	48E22916S01	DIO,1SS133-T-77 -AX
Q708	48E22902S01	TR,2SC2412K-Q,R,S-T146-CP DR	D704	48E22916S01	DIO,1SS133-T-77 -AX
Q711	48E22902S01	TR,2SC2412K-Q,R,S-T146-CP DR	D705	48E22916S01	DIO,1SS133-T-77 -AX
Q712	48E22900S01	TR,2SA1037K-Q,R,S-CP FQ			

Symbol No.	Part No.	Description
D706	48E22916S01	DIO,1SS133-T-77 -AX
D707	48E22916S01	DIO,1SS133-T-77 -AX
D708	48E22916S01	DIO,1SS133-T-77 -AX
D801	48E23703S01	DIO,1N 4003 -AX
D804	48E22916S01	DIO,1SS133-T-77 -AX
D805	48E22916S01	DIO,1SS133-T-77 -AX
D806	48E22916S01	DIO,1SS133-T-77 -AX
D807	48E22916S01	DIO,1SS133-T-77 -AX
D808	48E22916S01	DIO,1SS133-T-77 -AX
D809	48E22916S01	DIO,1SS133-T-77 -AX
D810	48E23703S01	DIO,1N 4003 -AX
D811	48E22916S01	DIO,1SS133-T-77 -AX
D812	48E22916S01	DIO,1SS133-T-77 -AX
D813	48E22916S01	DIO,1SS133-T-77 -AX
D814	48E23703S01	DIO,1N 4003 -AX
ZD601	48E22162S01	DIO,ZEN,MTZJ9.1B-AX
ZD602	48E25567S01	DIO,ZEN,MTZJ27B -AX
ZD603	48E25567S01	DIO,ZEN,MTZJ27B -AX
ZD701	48E22944S01	DIO,ZEN,MTZJ5.1B-AX
ZD702	48E08332S01	DIO,ZEN,MTZJ22B -AX
ZD801	48E29520S01	DIO,ZEN,MTZJ4.3B -AX
ZD802	48E22162S01	DIO,ZEN,MTZJ9.1B-AX
ZD803	48E29521S01	DIO,ZEN,MTZJ6.2B-AX
ZD804	48E22917S01	DIO,ZEN,MTZJ6.8A-AX
Coils		
L603	24E29518S01	CHOKE COIL(100uH)
L604	24E29518S01	CHOKE COIL(100uH)
L605	24E29459S01	CHOKE COIL(60uH, 20A)
L606	24E29459S01	CHOKE COIL(60uH, 20A)
L801	24E29518S01	CHOKE COIL(100uH)
Thermistors		
TH601	48E20887S01	TH,YTD5-320(20K)-YEL
TH602	48E20887S01	TH,YTD5-320(20K)-YEL
TH702	48E20887S01	TH,YTD5-320(20K)-YEL
TH703	48E20887S01	TH,YTD5-320(20K)-YEL
TH801	48E29453S01	TH,YTD5-210(1K)-RED
Transformers		
T601	25E29456S01	ASS'Y POWER TRANS
T602	25E29457S01	ASS'Y POWER TRANS
T801	25E29458S01	CHOKE TRANS 35m/m
T802	25E29458S01	CHOKE TRANS 35m/m

Symbol No.	Part No.	Description
Photo Couplers		
PT601	48E25501S01	PS2501-1(L)
PT602	48E25501S01	PS2501-1(L)
PT603	48E25501S01	PS2501-1(L)
PT604	48E25501S01	PS2501-1(L)
Capacitors		
C601	08E22969S01	CAP,TF,103-J -RD
C602	08E22969S01	CAP,TF,103-J -RD
C603	08E22435S01	CAP,TF,104-J -RD
C604	08E22435S01	CAP,TF,104-J -RD
C605	08E25318S01	CAP,TF,152-J -RD
C606	08E20756S01	CAP,TF,154-J -RD
C607	08E29517S01	CAP,TF,682-J -RD
C608	08E29517S01	CAP,TF,682-J -RD
C609	08E29517S01	CAP,TF,682-J -RD
C610	08E29517S01	CAP,TF,682-J -RD
C611	08E29509S01	CAP,CER,222-M-X -AX
C612	08E29509S01	CAP,CER,222-M-X -AX
C613	08E22524S01	CAP,TF,563-J -RD
C614	08E22524S01	CAP,TF,563-J -RD
C701	08E29509S01	CAP,CER,222-M-X -AX
C702	08E20756S01	CAP,TF,154-J -RD
C703	08E22899S01	CAP,CER,101-J-CP 50V
C705	08E22081S01	CAP,CER,102-J-CP 50V
C707	08E22081S01	CAP,CER,102-J-CP 50V
C708	08E22081S01	CAP,CER,102-J-CP 50V
C801	08E20756S01	CAP,TF,154-J -RD
C802	08E22081S01	CAP,CER,102-J-CP 50V
C806	08E22081S01	CAP,CER,102-J-CP 50V
C807	08E20756S01	CAP,TF,154-J -RD
C808	08E22969S01	CAP,TF,103-J -RD
E601	23E20208S01	CAP,ELEC,47/16 -RD
E602	23E23848S01	CAP,ELEC,220/10 -RD
E603	23E23848S01	CAP,ELEC,220/10 -RD
E604	23E08383S08	CAP,ELEC,10/16 -RD
E605	23E08383S08	CAP,ELEC,10/16 -RD
E606	23E08383S13	CAP,ELEC,22/16 -RD
E607	23E08383S13	CAP,ELEC,22/16 -RD
E608	23E08383S13	CAP,ELEC,22/16 -RD
E609	23E08383S13	CAP,ELEC,22/16 -RD
E610	23T25139Y01	CAP,PW 392 1C
E611	23T25139Y01	CAP,PW 392 1C
E612	23T25139Y01	CAP,PW 392 1C
E613	23T25139Y01	CAP,PW 392 1C
E614	23T25139Y01	CAP,PW 392 1C
E615	23T25139Y01	CAP,PW 392 1C

Symbol No.	Part No.	Description
E616	23T25139Y01	CAP,PW 392 1C
E617	23T25273Y04	CAP,LPO 472 1J +
E618	23T25273Y04	CAP,LPO 472 1J +
E619	23T25273Y04	CAP,LPO 472 1J +
E620	23T25273Y04	CAP,LPO 472 1J +
E621	23E29452S01	CAP,ELEC,220/100
E622	23E29452S01	CAP,ELEC,220/100
E623	23E29452S01	CAP,ELEC,220/100
E624	23E29452S01	CAP,ELEC,220/100
E701	23E08383S08	CAP,ELEC,10/16 -RD
E702	23E22905S01	CAP,ELEC,2.2/50 -RD
E703	23E29495S01	CAP,ELE,10/16-BP-RD
E704	23E29495S01	CAP,ELE,10/16-BP-RD
E705	23E11142S01	CAP,ELE,100/10-BP-RD
E706	23E22158S01	CAP,ELEC,10/50 -RD
E707	23E22158S01	CAP,ELEC,10/50 -RD
E708	23E10238S01	CAP,ELEC,100/16 -RD
E709	23E08383S18	CAP,ELEC,0.1/50 -RD
E710	23E20210S01	CAP,ELEC,220/16 -RD
E711	23E10238S01	CAP,ELEC,100/16 -RD
E801	23E10238S01	CAP,ELEC,100/16 -RD
E802	23E08383S13	CAP,ELEC,22/16 -RD
E803	23E23848S01	CAP,ELEC,220/10 -RD
E804	23E08383S08	CAP,ELEC,10/16 -RD
E805	23E08383S08	CAP,ELEC,10/16 -RD
E806	23E22905S01	CAP,ELEC,2.2/50 -RD

Resistors

R601	06E22048S01	RES,CF,102-J-1/10-CP
R602	06E22048S01	RES,CF,102-J-1/10-CP
R603	06E20903S01	RES,CF,103-J-1/10 -CP
R604	06E23857S01	RES,CF,511-J-1/10 -CP
R605	06E20903S01	RES,CF,103-J-1/10 -CP
R606	06E23857S01	RES,CF,511-J-1/10 -CP
R607	—	RES,CF,103-J-1/8 -AX
R608	—	RES,CF,103-J-1/8 -AX
R609	06E22112S01	RES,CF,113-J-1/10 -CP
R610	06E22924S01	RES,CF,242-J-1/10-CP
R611	06E22065S01	RES,CF,104-J-1/10 -CP
R612	06E24358S01	RES,CF,623-J-1/10-CP
R613	06E22040S01	RES,CF,10R-J-1/10 -CP
R614	06E22112S01	RES,CF,113-J-1/10 -CP
R615	06E22924S01	RES,CF,242-J-1/10-CP
R616	06E24358S01	RES,CF,623-J-1/10-CP
R617	06E22065S01	RES,CF,104-J-1/10 -CP
R618	06E22040S01	RES,CF,10R-J-1/10 -CP
R619	06E20903S01	RES,CF,103-J-1/10 -CP

Symbol No.	Part No.	Description
R620	06E22059S01	RES,CF,183-J-1/10-CP
R621	06E29515S01	RES,MO,1W 101E -RD
R622	06E29515S01	RES,MO,1W 101E -RD
R623	06E29515S01	RES,MO,1W 101E -RD
R624	06E29515S01	RES,MO,1W 101E -RD
R625	—	RES,CF,75R-J-1/8 -AX
R626	—	RES,CF,75R-J-1/8 -AX
R627	—	RES,CF,75R-J-1/8 -AX
R628	—	RES,CF,75R-J-1/8 -AX
R629	—	RES,CF,102-J-1/4 -AX
R630	—	RES,CF,10R-J-1/8 -AX
R631	—	RES,CF,10R-J-1/8 -AX
R632	—	RES,CF,10R-J-1/8 -AX
R633	—	RES,CF,10R-J-1/8 -AX
R634	—	RES,CF,681-J-1/8 -AX
R635	—	RES,CF,681-J-1/8 -AX
R636	—	RES,CF,681-J-1/8 -AX
R637	—	RES,CF,681-J-1/8 -AX
R638	—	RES,CF,10R-J-1/8 -AX
R639	—	RES,CF,10R-J-1/8 -AX
R640	—	RES,CF,10R-J-1/8 -AX
R641	—	RES,CF,10R-J-1/8 -AX
R642	—	RES,CF,681-J-1/8 -AX
R643	—	RES,CF,681-J-1/8 -AX
R644	—	RES,CF,681-J-1/8 -AX
R645	—	RES,CF,681-J-1/8 -AX
R646	—	RES,CF,10R-J-1/8 -AX
R647	—	RES,CF,10R-J-1/8 -AX
R648	—	RES,CF,10R-J-1/8 -AX
R649	—	RES,CF,10R-J-1/8 -AX
R650	—	RES,CF,681-J-1/8 -AX
R651	—	RES,CF,681-J-1/8 -AX
R652	—	RES,CF,681-J-1/8 -AX
R653	—	RES,CF,681-J-1/8 -AX
R654	06E20907S01	RES,MO,1W 100E -RD
R655	06E20907S01	RES,MO,1W 100E -RD
R656	06E20907S01	RES,MO,1W 100E -RD
R657	06E20907S01	RES,MO,1W 100E -RD
R662	06E20903S01	RES,CF,103-J-1/10 -CP
R663	06E29516S01	RES,MO,1W 103E -RD
R664	06E29516S01	RES,MO,1W 103E -RD
R665	06E20903S01	RES,CF,103-J-1/10 -CP
R666	06E20903S01	RES,CF,103-J-1/10 -CP
R677	—	RES,CF,391-J-1/4 -S
R680	—	RES,CF,391-J-1/4 -S
R701	06E23593S01	RES,CF,153-J-1/8 -CP
R702	06E20903S01	RES,CF,103-J-1/10 -CP
R703	06E22894S01	RES,CF,132-J-1/10-CP
R704	06E22065S01	RES,CF,104-J-1/10 -CP

Symbol No.	Part No.	Description	Symbol No.	Part No.	Description
R705	06E22059S01	RES,CF,183-J-1/10-CP	R810	06E22509S01	RES,CF,154-J-1/10 -CP
R706	06E26529S01	RES,CF,75R-J-1/10 -CP	R811	06E22030S01	RES,CF,102-J-1/8 -CP
R707	06E22060S01	RES,CF,223-J-1/10-CP	R812	06E22048S01	RES,CF,102-J-1/10-CP
R708	06E20903S01	RES,CF,103-J-1/10 -CP	R813	06E22030S01	RES,CF,102-J-1/8 -CP
R709	06E22030S01	RES,CF,102-J-1/8 -CP	R814	06E22030S01	RES,CF,102-J-1/8 -CP
R710	06E22656S01	RES,CF,682-J-1/8 -CP	R815	06E20903S01	RES,CF,103-J-1/10 -CP
R711	06E22048S01	RES,CF,102-J-1/10-CP	R816	06E22030S01	RES,CF,102-J-1/8 -CP
R712	06E22048S01	RES,CF,102-J-1/10-CP	R817	06E22030S01	RES,CF,102-J-1/8 -CP
R713	06E22037S01	RES,CF,104-J-1/8 -CP	R818	06E22058S01	RES,CF,123-J-1/10 -CP
R714	06E26014S01	RES,CF,103-J-1/8 -CP	R819	06E22065S01	RES,CF,104-J-1/10 -CP
R715	—	RES,CF,103-J-1/8 -AX	R820	06E22033S01	RES,CF,472-J-1/8 -CP
R716	—	RES,CF,103-J-1/8 -AX	R821	06E22037S01	RES,CF,104-J-1/8 -CP
R717	06E23685S01	RES,CF,113-J-1/8 -CP	R822	06E22545S01	RES,CF,202-J-1/10 -CP
R719	06E20903S01	RES,CF,103-J-1/10 -CP	R823	06E22545S01	RES,CF,202-J-1/10 -CP
R720	06E22048S01	RES,CF,102-J-1/10-CP	R824	06E22068S01	RES,CF,105-J-1/10 -CP
R721	06E26014S01	RES,CF,103-J-1/8 -CP	R825	06E22547S01	RES,CF,684-J-1/10-CP
R722	06E29511S01	RES,CF,683-J-1/8 -CP	R826	06E22037S01	RES,CF,104-J-1/8 -CP
R723	06E29512S01	RES,CF,753-J-1/8 -CP	VR601	18E20754S01	VR,EVNDJAA03 B10K-RD
R724	06E20903S01	RES,CF,103-J-1/10 -CP	VR602	18E20754S01	VR,EVNDJAA03 B10K-RD
R733	06E22048S01	RES,CF,102-J-1/10-CP			
R734	06E22048S01	RES,CF,102-J-1/10-CP	Connectors		
R735	06E22048S01	RES,CF,102-J-1/10-CP	CB602	09E29462S01	CONN BASE, 35313-0610
R736	06E22053S01	RES,CF,332-J-1/10 -CP	CB801	09E29460S01	CONN BASE, 53014-0210
R737	06E22053S01	RES,CF,332-J-1/10 -CP	CB802	09E29461S01	CONN BASE, 53014-0710
R738	—	RES,CF,102-J-1/8 -AX	CH601	01E29466S01	ASS'Y CONN WIRE 10PC-10PB
R739	06E22545S01	RES,CF,202-J-1/10 -CP	Front P.W.Board		
R740	06E22065S01	RES,CF,104-J-1/10 -CP	IC's		
R741	06E22111S01	RES,CF,562-J-1/10 -CP	IC101	51E22137S01	IC, µPC 4570HA
R742	—	RES,CF,103-J-1/8 -AX	IC102	51E22137S01	IC, µPC 4570HA
R743	—	RES,CF,203-J-1/8 -AX	IC103	51E29404S01	IC,NJM 4560L
R744	06E23823S01	RES,CF,111-J-1/8 -CP	IC201	51E29404S01	IC,NJM 4560L
R745	06E29585S01	RES,CF,56R-J-1/10 -CP	IC202	51E29404S01	IC,NJM 4560L
R746	06E23823S01	RES,CF,111-J-1/8 -CP	IC203	51E29404S01	IC,NJM 4560L
R747	06E29585S01	RES,CF,56R-J-1/10 -CP	IC204	51E29404S01	IC,NJM 4560L
R748	06E20903S01	RES,CF,103-J-1/10 -CP	IC205	51E29404S01	IC,NJM 4560L
R749	06E26014S01	RES,CF,103-J-1/8 -CP	IC206	51E29404S01	IC,NJM 4560L
R750	06E23743S01	RES,CF,244-J-1/10 -CP	IC207	51E29404S01	IC,NJM 4560L
R751	06E22066S01	RES,CF,224-J-1/10 -CP	IC208	51E29404S01	IC,NJM 4560L
R752	06E22055S01	RES,CF,472-J-1/10 -CP	IC209	51E22130S01	IC,NJM 4560M-TE3
R753	06E20903S01	RES,CF,103-J-1/10 -CP	IC401	51E22137S01	IC, µPC 4570HA
R754	06E22953S01	RES,CF,303-J-1/10 -CP			
R801	06E20903S01	RES,CF,103-J-1/10 -CP			
R802	06E22506S01	RES,CF,362-J-1/10 -CP			
R803	06E22509S01	RES,CF,154-J-1/10 -CP			
R804	06E24140S01	RES,CF,332-J-1/8 -CP			
R805	06E22052S01	RES,CF,272-J-1/10-CP			
R806	06E22111S01	RES,CF,562-J-1/10 -CP			
R808	06E22030S01	RES,CF,102-J-1/8 -CP			
R809	06E22509S01	RES,CF,154-J-1/10 -CP			

Symbol No.	Part No.	Description
Transistors/FET's		
Q401	48E08335S01	TR,KTC 2878-B -RD
Q402	48E08335S01	TR,KTC 2878-B -RD
Q403	48T61719F01	FET,TKR 2SK 389BL
Q404	48T61719F01	FET,TKR 2SK 389BL
Q405	48E27752S01	TR,KSA992
Q406	48E27752S01	TR,KSA992
Q407	48E27752S01	TR,KSA992
Q408	48E27752S01	TR,KSA992
Q409	48E27753S01	TR,KSC 1845
Q410	48E27753S01	TR,KSC 1845
Q411	48E27753S01	TR,KSC 1845
Q412	48E27753S01	TR,KSC 1845
Q413	48E23701S01	TR,KTC 3228-O -RD
Q414	48E23701S01	TR,KTC 3228-O -RD
Q415	48E10027S01	TR,KSC 2690A-Y
Q416	48E10027S01	TR,KSC 2690A-Y
Q417	48E05943S01	TR,KSA 1220A-Y
Q418	48E05943S01	TR,KSA 1220A-Y
Q419	48E08329S01	TR,KSC 2682-Y
Q420	48E08329S01	TR,KSC 2682-Y
Q421	48E10027S01	TR,KSC 2690A-Y
Q422	48E10027S01	TR,KSC 2690A-Y
Q423	48E10027S01	TR,KSC 2690A-Y
Q424	48E10027S01	TR,KSC 2690A-Y
Q425	48E05943S01	TR,KSA 1220A-Y
Q426	48E05943S01	TR,KSA 1220A-Y
Q427	48E05943S01	TR,KSA 1220A-Y
Q428	48E05943S01	TR,KSA 1220A-Y
Q429	48E09036S02	TR,KTA 1266-Y -RD
Q430	48E09036S02	TR,KTA 1266-Y -RD
Q431	48E09088S01	TR,KTC 3198-Y -RD
Q432	48E09088S01	TR,KTC 3198-Y -RD
Q433	48E09088S01	TR,KTC 3198-Y -RD
Q434	48E09088S01	TR,KTC 3198-Y -RD
Q435	48E09036S02	TR,KTA 1266-Y -RD
Q436	48E09036S02	TR,KTA 1266-Y -RD
Q437	48E09088S01	TR,KTC 3198-Y -RD
Q438	48E09088S01	TR,KTC 3198-Y -RD
Q439	48E09036S02	TR,KTA 1266-Y -RD
Q440	48E09036S02	TR,KTA 1266-Y -RD
Q441	48E23701S01	TR,KTC 3228-O -RD
Q442	48E23701S01	TR,KTC 3228-O -RD
Q443	48E09088S01	TR,KTC 3198-Y -RD
Q444	48E09088S01	TR,KTC 3198-Y -RD
Q501	48T25535Y01	FET,IRF 540N
Q502	48T25535Y01	FET,IRF 540N
Q503	48T25535Y01	FET,IRF 540N

Symbol No.	Part No.	Description
Q504	48T25535Y01	FET,IRF 540N
Q505	48T25535Y01	FET,IRF 540N
Q506	48T25535Y01	FET,IRF 540N
Q507	48T25535Y01	FET,IRF 540N
Q508	48T25535Y01	FET,IRF 540N
Q509	48T25536Y01	FET,IRF 9540N
Q510	48T25536Y01	FET,IRF 9540N
Q511	48T25536Y01	FET,IRF 9540N
Q512	48T25536Y01	FET,IRF 9540N
Q513	48T25536Y01	FET,IRF 9540N
Q514	48T25536Y01	FET,IRF 9540N
Q515	48T25536Y01	FET,IRF 9540N
Q516	48T25536Y01	FET,IRF 9540N
Q617	48E10027S01	TR,KSC 2690A-Y
Q618	48E05943S01	TR,KSA 1220A-Y
Q619	48E10027S01	TR,KSC 2690A-Y
Q620	48E05943S01	TR,KSA 1220A-Y
Q709	48E05943S01	TR,KSA 1220A-Y
Q710	48E05943S01	TR,KSA 1220A-Y
Q718	48E27753S01	TR,KSC 1845
Q719	48E27753S01	TR,KSC 1845
Diodes		
D401	48E22916S01	DIO,1SS133-T-77 -AX
D402	48E22916S01	DIO,1SS133-T-77 -AX
D403	48E22916S01	DIO,1SS133-T-77 -AX
D404	48E22916S01	DIO,1SS133-T-77 -AX
D405	48E22916S01	DIO,1SS133-T-77 -AX
D406	48E22916S01	DIO,1SS133-T-77 -AX
D501	48E25517S01	DIO,11EFS2
D502	48E25517S01	DIO,11EFS2
D503	48E25517S01	DIO,11EFS2
D504	48E25517S01	DIO,11EFS2
D505	48E25517S01	DIO,11EFS2
D506	48E25517S01	DIO,11EFS2
D507	48E25517S01	DIO,11EFS2
D508	48E25517S01	DIO,11EFS2
D509	48E25517S01	DIO,11EFS2
D510	48E25517S01	DIO,11EFS2
D511	48E25517S01	DIO,11EFS2
D512	48E25517S01	DIO,11EFS2
D513	48E25517S01	DIO,11EFS2
D514	48E25517S01	DIO,11EFS2
D515	48E25517S01	DIO,11EFS2
D516	48E25517S01	DIO,11EFS2
D610	48E25517S01	DIO,11EFS2
D611	48E25517S01	DIO,11EFS2

Symbol No.	Part No.	Description	Symbol No.	Part No.	Description
ZD501	48T83128F26	DIO,ZEN,HZS 9C2L -A5	C221	08E08423S03	CAP,CER,100-D-CP 50V
ZD502	48T83128F26	DIO,ZEN,HZS 9C2L -A5	C402	08E23581S01	CAP,CER,330-J-CP 50V
ZD503	48T25801W01	DIO,ZEN,HZS 2ALL-R5	C403	08E23695S01	CAP,CER,5R0-C-CP 50V
ZD504	48T25801W01	DIO,ZEN,HZS 2ALL-R5	C404	08E20918S01	CAP,CER,181-K-B -AX
ZD604	48E29510S01	DIO,ZEN,MTZJ27D -AX	C405	08E20918S01	CAP,CER,181-K-B -AX
ZD605	48E29510S01	DIO,ZEN,MTZJ27D -AX	C406	21E06808S03	CAP,CER,102-J-B -AX
ZD606	48E29510S01	DIO,ZEN,MTZJ27D -AX	C407	21E06808S03	CAP,CER,102-J-B -AX
ZD607	48E29510S01	DIO,ZEN,MTZJ27D -AX	C408	08E22435S01	CAP,TF,104-J -RD
ZD608	48E22436S01	DIO,ZEN,MTZJ16B -AX	C409	08E22435S01	CAP,TF,104-J -RD
ZD609	48E22436S01	DIO,ZEN,MTZJ16B -AX	C410	08E22435S01	CAP,TF,104-J -RD
Switches			C411	08E22435S01	CAP,TF,104-J -RD
SW201	40E23679S01	S/W,SSAF122NA (PARAME EQ)	C412	08E29508S01	CAP,CER,470-J-SL -AX
SW301	40E20895S01	S/W,SSAF123NA (FILTER)	C413	08E29508S01	CAP,CER,470-J-SL -AX
SW302	40E20895S01	S/W,SSAF123NA (INPUT MODE)	C414	08E20072S01	CAP,CER,100-J-CH -AX
SW401	40T94668F06	S/W,SSSF142 (PHASE)	C415	08E20072S01	CAP,CER,100-J-CH -AX
Capacitors			C416	08E22969S01	CAP,TF,103-J -RD
C101	08E23598S01	CAP,CER,101-J-CP 50V	C417	08E22969S01	CAP,TF,103-J -RD
C102	08E23598S01	CAP,CER,101-J-CP 50V	C418	08E20073S01	CAP,CER,151-K-B -AX
C103	08E25511S01	CAP,CER,330-J-CP 50V	C419	08E20073S01	CAP,CER,151-K-B -AX
C104	08E23581S01	CAP,CER,330-J-CP 50V	C420	08E20073S01	CAP,CER,151-K-B -AX
C105	08E23581S01	CAP,CER,330-J-CP 50V	C421	08E20073S01	CAP,CER,151-K-B -AX
C106	08E23581S01	CAP,CER,330-J-CP 50V	C422	08E20073S01	CAP,CER,151-K-B -AX
C107	08E08423S03	CAP,CER,100-D-CP 50V	C423	08E20073S01	CAP,CER,151-K-B -AX
C108	08E08423S03	CAP,CER,100-D-CP 50V	C424	08E20073S01	CAP,CER,151-K-B -AX
C109	08E20917S01	CAP,CER,101-K-B -AX	C425	08E20073S01	CAP,CER,151-K-B -AX
C201	08E22899S01	CAP,CER,101-J-CP 50V	C426	08E20073S01	CAP,CER,151-K-B -AX
C202	08E22899S01	CAP,CER,101-J-CP 50V	C427	08E20073S01	CAP,CER,151-K-B -AX
C203	08E22899S01	CAP,CER,101-J-CP 50V	C428	08E20073S01	CAP,CER,151-K-B -AX
C204	08E22899S01	CAP,CER,101-J-CP 50V	C429	08E20073S01	CAP,CER,151-K-B -AX
C205	08E22435S01	CAP,TF,104-J -RD	C430	08E20073S01	CAP,CER,151-K-B -AX
C206	08E22435S01	CAP,TF,104-J -RD	C431	08E20073S01	CAP,CER,151-K-B -AX
C207	08E22435S01	CAP,TF,104-J -RD	C432	08E20073S01	CAP,CER,151-K-B -AX
C208	08E22435S01	CAP,TF,104-J -RD	C433	08E20073S01	CAP,CER,151-K-B -AX
C209	08E20756S01	CAP,TF,154-J -RD	C434	08E29509S01	CAP,CER,222-M-X -AX
C210	08E20756S01	CAP,TF,154-J -RD	C435	08E29509S01	CAP,CER,222-M-X -AX
C211	08E20756S01	CAP,TF,154-J -RD	C436	08E29509S01	CAP,CER,222-M-X -AX
C212	08E20756S01	CAP,TF,154-J -RD	C437	08E29509S01	CAP,CER,222-M-X -AX
C213	08E27616S01	CAP,TF,334-J -RD	C438	08E22525S01	CAP,TF,683-J -RD
C214	08E27616S01	CAP,TF,334-J -RD	C439	08E22525S01	CAP,TF,683-J -RD
C216	08E22435S01	CAP,TF,104-J -RD	C440	08E22525S01	CAP,TF,683-J -RD
C217	08E22526S01	CAP,TF,823-J -RD	C441	08E22525S01	CAP,TF,683-J -RD
C218	08E23699S01	CAP,TF,224-J -RD	C442	21E06808S03	CAP,CER,102-J-B -AX
C219	08E20755S01	CAP,TF,333-J -RD	C443	21E06808S03	CAP,CER,102-J-B -AX
C220	08E27616S01	CAP,TF,334-J -RD	C501	08E22938S01	CAP,TF,473-J -RD
			C502	08E22938S01	CAP,TF,473-J -RD
			C615	08E22524S01	CAP,TF,563-J -RD
			C616	08E22524S01	CAP,TF,563-J -RD
			C617	08E22524S01	CAP,TF,563-J -RD
			C618	08E22524S01	CAP,TF,563-J -RD

Symbol No.	Part No.	Description
E101	23E29495S01	CAP,ELE,10/16-BP-RD
E102	23E29495S01	CAP,ELE,10/16-BP-RD
E103	23E08383S08	CAP,ELEC,10/16 -RD
E104	23E08383S08	CAP,ELEC,10/16 -RD
E105	23E08383S16	CAP,ELEC,4.7/50 -RD
E106	23E08383S16	CAP,ELEC,4.7/50 -RD
E107	23E08383S16	CAP,ELEC,4.7/50 -RD
E108	23E08383S16	CAP,ELEC,4.7/50 -RD
E201	23E08383S08	CAP,ELEC,10/16 -RD
E202	23E08383S08	CAP,ELEC,10/16 -RD
E203	23E08383S08	CAP,ELEC,10/16 -RD
E204	23E08383S08	CAP,ELEC,10/16 -RD
E205	23E08383S08	CAP,ELEC,10/16 -RD
E206	23E08383S08	CAP,ELEC,10/16 -RD
E207	23E08383S08	CAP,ELEC,10/16 -RD
E401	23E29496S01	CAP,ELE,22/16-BP-RD
E402	23E29496S01	CAP,ELE,22/16-BP-RD
E403	23E08383S16	CAP,ELEC,4.7/50 -RD
E404	23E08383S16	CAP,ELEC,4.7/50 -RD
E405	23E29496S01	CAP,ELE,22/16-BP-RD
E406	23E29496S01	CAP,ELE,22/16-BP-RD
E407	23E29494S01	CAP,ELE,220/10-BP-RD
E408	23E29494S01	CAP,ELE,220/10-BP-RD
E409	23E29493S01	CAP,ELEC,22/50 -RD
E410	23E29493S01	CAP,ELEC,22/50 -RD
E411	23E08383S16	CAP,ELEC,4.7/50 -RD
E412	23E08383S16	CAP,ELEC,4.7/50 -RD
E501	23E29476S01	CAP,ELEC,220/100
E502	23E29476S01	CAP,ELEC,220/100
E503	23E29476S01	CAP,ELEC,220/100
E504	23E29476S01	CAP,ELEC,220/100
E505	23E29476S01	CAP,ELEC,220/100
E506	23E29476S01	CAP,ELEC,220/100
E507	23E29476S01	CAP,ELEC,220/100
E508	23E29476S01	CAP,ELEC,220/100
E509	23E29476S01	CAP,ELEC,220/100
E510	23E29476S01	CAP,ELEC,220/100
E511	23E29476S01	CAP,ELEC,220/100
E512	23E29476S01	CAP,ELEC,220/100
E513	23E29476S01	CAP,ELEC,220/100
E514	23E29476S01	CAP,ELEC,220/100
E515	23E29476S01	CAP,ELEC,220/100
E516	23E29476S01	CAP,ELEC,220/100
E625	23E25561S01	CAP,ELEC,10/63 -RD
E626	23E25561S01	CAP,ELEC,10/63 -RD
E627	23E25563S01	CAP,ELEC,220/63 -RD
E628	23E25563S01	CAP,ELEC,220/63 -RD
E629	23E25562S01	CAP,ELEC,22/63 -RD
E630	23E25562S01	CAP,ELEC,22/63 -RD

Symbol No.	Part No.	Description
E631	23E20210S01	CAP,ELEC,220/16 -RD
E632	23E20210S01	CAP,ELEC,220/16 -RD
Resistors		
R101	—	RES,CF,101-J-1/8 -AX
R102	—	RES,CF,101-J-1/8 -AX
R103	—	RES,CF,223-J-1/8 -AX
R104	—	RES,CF,223-J-1/8 -AX
R105	—	RES,CF,751-J-1/8 -AX
R106	—	RES,CF,751-J-1/8 -AX
R107	—	RES,CF,622-J-1/8 -AX
R108	—	RES,CF,622-J-1/8 -AX
R109	—	RES,CF,103-J-1/8 -AX
R110	—	RES,CF,103-J-1/8 -AX
R111	—	RES,CF,152-J-1/8 -AX
R112	—	RES,CF,152-J-1/8 -AX
R113	—	RES,CF,911-J-1/8 -AX
R114	—	RES,CF,911-J-1/8 -AX
R117	—	RES,CF,223-J-1/8 -AX
R118	—	RES,CF,223-J-1/8 -AX
R119	—	RES,CF,101-J-1/8 -AX
R120	—	RES,CF,101-J-1/8 -AX
R121	—	RES,CF,273-J-1/8 -AX
R122	—	RES,CF,273-J-1/8 -AX
R123	—	RES,CF,751-J-1/8 -AX
R124	—	RES,CF,751-J-1/8 -AX
R125	—	RES,CF,273-J-1/8 -AX
R126	—	RES,CF,273-J-1/8 -AX
R201	06E22062S01	RES,CF,473-J-1/10-CP
R202	06E22921S01	RES,CF,473-J-1/8 -CP
R203	06E22060S01	RES,CF,223-J-1/10-CP
R204	06E22036S01	RES,CF,223-J-1/8 -CP
R205	06E22060S01	RES,CF,223-J-1/10-CP
R206	06E22060S01	RES,CF,223-J-1/10-CP
R207	06E22036S01	RES,CF,223-J-1/8 -CP
R208	06E22060S01	RES,CF,223-J-1/10-CP
R209	06E22060S01	RES,CF,223-J-1/10-CP
R210	06E22060S01	RES,CF,223-J-1/10-CP
R211	06E26014S01	RES,CF,103-J-1/8 -CP
R212	06E20903S01	RES,CF,103-J-1/10 -CP
R213	06E22062S01	RES,CF,473-J-1/10-CP
R214	06E22921S01	RES,CF,473-J-1/8 -CP
R215	06E22896S01	RES,CF,912-J-1/10 -CP
R216	06E22896S01	RES,CF,912-J-1/10 -CP
R217	06E20903S01	RES,CF,103-J-1/10 -CP
R218	06E20903S01	RES,CF,103-J-1/10 -CP
R219	06E20903S01	RES,CF,103-J-1/10 -CP

Symbol No.	Part No.	Description	Symbol No.	Part No.	Description
R220	06E26014S01	RES,CF,103-J-1/8 -CP	R420	—	RES,CF,121-J-1/8 -AX
R221	06E22057S01	RES,CF,822-J-1/10 -CP	R421	—	RES,CF,121-J-1/8 -AX
R222	06E22057S01	RES,CF,822-J-1/10 -CP	R422	—	RES,CF,471-J-1/8 -AX
R223	06E22507S01	RES,CF,153-J-1/10 -CP	R423	—	RES,CF,471-J-1/8 -AX
R224	06E22507S01	RES,CF,153-J-1/10 -CP	R424	—	RES,CF,101-J-1/8 -AX
R225	06E22128S01	RES,CF,822-J-1/8 -CP	R425	—	RES,CF,101-J-1/8 -AX
R226	—	RES,CF,822-J-1/8 -AX	R426	—	RES,CF,301-J-1/8 -AX
R227	06E23733S01	RES,CF,431-J-1/8 -CP	R427	—	RES,CF,301-J-1/8 -AX
R228	06E22044S01	RES,CF,431-J-1/10 -CP	R428	—	RES,CF,683-J-1/8 -AX
R229	06E22506S01	RES,CF,362-J-1/10 -CP	R429	—	RES,CF,683-J-1/8 -AX
R230	06E22506S01	RES,CF,362-J-1/10 -CP	R430	—	RES,CF,121-J-1/8 -AX
R231	06E22926S01	RES,CF,752-J-1/10 -CP	R431	—	RES,CF,121-J-1/8 -AX
R232	06E22926S01	RES,CF,752-J-1/10 -CP	R432	—	RES,CF,101-J-1/8 -AX
R233	06E22508S01	RES,CF,203-J-1/10 -CP	R433	—	RES,CF,101-J-1/8 -AX
R234	06E22508S01	RES,CF,203-J-1/10 -CP	R434	06E29492S01	RES,MO,1W 243E -RD
R235	06E20903S01	RES,CF,103-J-1/10 -CP	R435	06E29492S01	RES,MO,1W 243E -RD
R236	06E22129S01	RES,CF,243-J-1/10-CP	R436	—	RES,CF,331-J-1/8 -AX
R237	06E22037S01	RES,CF,104-J-1/8 -CP	R437	—	RES,CF,331-J-1/8 -AX
R238	06E22062S01	RES,CF,473-J-1/10-CP	R438	—	RES,CF,201-J-1/8 -AX
R239	06E22057S01	RES,CF,822-J-1/10 -CP	R439	—	RES,CF,201-J-1/8 -AX
R240	06E22057S01	RES,CF,822-J-1/10 -CP	R440	—	RES,CF,33R-J-1/8 -AX
R241	06E22128S01	RES,CF,822-J-1/8 -CP	R441	—	RES,CF,33R-J-1/8 -AX
R242	06E22057S01	RES,CF,822-J-1/10 -CP	R442	—	RES,CF,202-J-1/8 -AX
R243	—	RES,CF,102-J-1/8 -AX	R443	—	RES,CF,202-J-1/8 -AX
R244	—	RES,CF,102-J-1/8 -AX	R444	—	RES,CF,243-J-1/8 -AX
R245	06E22062S01	RES,CF,473-J-1/10-CP	R445	—	RES,CF,243-J-1/8 -AX
R246	06E26014S01	RES,CF,103-J-1/8 -CP	R446	—	RES,CF,622-J-1/8 -AX
R247	06E20903S01	RES,CF,103-J-1/10 -CP	R447	—	RES,CF,622-J-1/8 -AX
R248	06E20904S01	RES,CF,273-J-1/10 -CP	R448	—	RES,CF,102-J-1/8 -AX
R251	06E20904S01	RES,CF,273-J-1/10 -CP	R449	—	RES,CF,102-J-1/8 -AX
R401	—	RES,CF,103-J-1/8 -AX	R450	06E29618S01	RES,MF,4R7-J-1/4 -AX
R402	—	RES,CF,103-J-1/8 -AX	R451	06E29618S01	RES,MF,4R7-J-1/4 -AX
R403	—	RES,CF,751-J-1/8 -AX	R452	06E29618S01	RES,MF,4R7-J-1/4 -AX
R404	—	RES,CF,103-J-1/8 -AX	R453	06E29618S01	RES,MF,4R7-J-1/4 -AX
R405	—	RES,CF,273-J-1/8 -AX	R454	06E29618S01	RES,MF,4R7-J-1/4 -AX
R406	—	RES,CF,273-J-1/8 -AX	R455	06E29618S01	RES,MF,4R7-J-1/4 -AX
R407	—	RES,CF,472-J-1/8 -AX	R456	06E29618S01	RES,MF,4R7-J-1/4 -AX
R408	—	RES,CF,472-J-1/8 -AX	R457	06E29618S01	RES,MF,4R7-J-1/4 -AX
R409	—	RES,CF,103-J-1/8 -AX	R458	06E29491S01	RES,MO,1W 561E -RD
R410	—	RES,CF,103-J-1/8 -AX	R459	06E29491S01	RES,MO,1W 561E -RD
R411	—	RES,CF,472-J-1/8 -AX	R460	—	RES,CF,102-J-1/8 -AX
R412	—	RES,CF,472-J-1/8 -AX	R461	—	RES,CF,102-J-1/8 -AX
R413	—	RES,CF,103-J-1/8 -AX	R462	—	RES,CF,182-J-1/8 -AX
R414	06E26014S01	RES,CF,103-J-1/8 -CP	R463	—	RES,CF,182-J-1/8 -AX
R415	—	RES,CF,473-J-1/8 -AX	R464	—	RES,CF,182-J-1/8 -AX
R416	—	RES,CF,473-J-1/8 -AX	R465	—	RES,CF,182-J-1/8 -AX
R417	06E22068S01	RES,CF,105-J-1/10 -CP	R466	—	RES,CF,102-J-1/8 -AX
R418	06E22067S01	RES,CF,474-J-1/10 -CP	R467	—	RES,CF,102-J-1/8 -AX
R419	06E22067S01	RES,CF,474-J-1/10 -CP	R468	—	RES,CF,102-J-1/8 -AX

Symbol No.	Part No.	Description
R469	—	RES,CF,102-J-1/8 -AX
R470	—	RES,CF,103-J-1/8 -AX
R471	—	RES,CF,103-J-1/8 -AX
R472	—	RES,CF,223-J-1/8 -AX
R473	—	RES,CF,223-J-1/8 -AX
R474	—	RES,CF,103-J-1/8 -AX
R475	—	RES,CF,103-J-1/8 -AX
R476	—	RES,CF,103-J-1/8 -AX
R477	—	RES,CF,103-J-1/8 -AX
R478	—	RES,CF,103-J-1/8 -AX
R479	—	RES,CF,103-J-1/8 -AX
R480	—	RES,CF,152-J-1/8 -AX
R481	—	RES,CF,152-J-1/8 -AX
R482	—	RES,CF,102-J-1/8 -AX
R483	—	RES,CF,102-J-1/8 -AX
R501	06E29621S01	RES,MF,33R-J-1/4 -AX
R503	06E29621S01	RES,MF,33R-J-1/4 -AX
R505	06E29621S01	RES,MF,33R-J-1/4 -AX
R507	06E29621S01	RES,MF,33R-J-1/4 -AX
R509	06E29621S01	RES,MF,33R-J-1/4 -AX
R511	06E29621S01	RES,MF,33R-J-1/4 -AX
R513	06E29621S01	RES,MF,33R-J-1/4 -AX
R515	06E29621S01	RES,MF,33R-J-1/4 -AX
R517	06E29621S01	RES,MF,33R-J-1/4 -AX
R519	06E29621S01	RES,MF,33R-J-1/4 -AX
R521	06E29621S01	RES,MF,33R-J-1/4 -AX
R523	06E29621S01	RES,MF,33R-J-1/4 -AX
R525	06E29621S01	RES,MF,33R-J-1/4 -AX
R527	06E29621S01	RES,MF,33R-J-1/4 -AX
R529	06E29621S01	RES,MF,33R-J-1/4 -AX
R531	06E29621S01	RES,MF,33R-J-1/4 -AX
R533	06E29622S01	RES,MF,154-J-1/4 -AX
R534	06E29622S01	RES,MF,154-J-1/4 -AX
R535	06E29622S01	RES,MF,154-J-1/4 -AX
R536	06E29622S01	RES,MF,154-J-1/4 -AX
R537	06E29622S01	RES,MF,154-J-1/4 -AX
R538	06E29622S01	RES,MF,154-J-1/4 -AX
R539	06E29622S01	RES,MF,154-J-1/4 -AX
R540	06E29622S01	RES,MF,154-J-1/4 -AX
R541	06E29622S01	RES,MF,154-J-1/4 -AX
R542	06E29622S01	RES,MF,154-J-1/4 -AX
R543	06E29622S01	RES,MF,154-J-1/4 -AX
R544	06E29622S01	RES,MF,154-J-1/4 -AX
R545	06E29622S01	RES,MF,154-J-1/4 -AX
R546	06E29622S01	RES,MF,154-J-1/4 -AX
R547	06E29622S01	RES,MF,154-J-1/4 -AX
R548	06E29622S01	RES,MF,154-J-1/4 -AX
R549	06E22136S01	RES,MPR 5W 0.1X2
R550	06E22136S01	RES,MPR 5W 0.1X2

Symbol No.	Part No.	Description
R551	06E22136S01	RES,MPR 5W 0.1X2
R552	06E22136S01	RES,MPR 5W 0.1X2
R553	06E22136S01	RES,MPR 5W 0.1X2
R554	06E22136S01	RES,MPR 5W 0.1X2
R555	06E22136S01	RES,MPR 5W 0.1X2
R556	06E22136S01	RES,MPR 5W 0.1X2
R557	06E20907S01	RES,MO,1W 100E -RD
R558	06E20907S01	RES,MO,1W 100E -RD
R658	06E29619S01	RES,MF,822-J-1/4 -AX
R659	06E29619S01	RES,MF,822-J-1/4 -AX
R660	06E29620S01	RES,MF,223-J-1/4 -AX
R661	06E29620S01	RES,MF,223-J-1/4 -AX
R725	—	RES,CF,122-J-1/8 -AX
R726	—	RES,CF,223-J-1/8 -AX
R727	—	RES,CF,104-J-1/8 -AX
R728	—	RES,CF,393-J-1/8 -AX
R729	—	RES,CF,122-J-1/8 -AX
R730	—	RES,CF,223-J-1/8 -AX
R731	—	RES,CF,104-J-1/8 -AX
R732	—	RES,CF,393-J-1/8 -AX
R782	—	RES,CF,103-J-1/8 -AX
R783	06E20903S01	RES,CF,103-J-1/10 -CP
R784	—	RES,CF,123-J-1/8 -AX
R785	—	RES,CF,123-J-1/8 -AX
R786	—	RES,CF,103-J-1/8 -AX
R787	—	RES,CF,101-J-1/8 -AX
R788	—	RES,CF,222-J-1/8 -AX
R789	—	RES,CF,103-J-1/8 -AX
R790	—	RES,CF,101-J-1/8 -AX
R791	—	RES,CF,222-J-1/8 -AX
VR401	18E25512S01	VR,EVNDJAA03 B1.5K-RD
VR402	18E25512S01	VR,EVNDJAA03 B1.5K-RD
Connectors		
CB601	09E29482S01	CONN BASE, 53014-1010
CB603	09E29462S01	CONN BASE, 35313-0610
CH101	01E29593S01	ASS'Y CONN WIRE 10PC-4PB
CH102	01E29486S01	ASS'Y CONN WIRE 9PC-9PB
CH103	01E29485S01	ASS'Y CONN WIRE 7PC-7PB
CH105	01E29488S01	ASS'Y CONN WIRE 12PC-12PB

Symbol No.	Part No.	Description
Volume (1) P.W.Board		
Resistors		
VR101	18E29471S01	VR, 50KAX2 (GAIN)
VR205	18E29475S01	VR, 50KEX2, 25KEX2 (HP)
VR206	18E29472S01	VR, 50KEX4 (LP)
Connectors		
CB101	09E29477S01	CONN BASE, 53015-0410
CB102	09E29480S01	CONN BASE, 53015-0910
CB103	09E29479S01	CONN BASE, 53015-0710
Volume (2) P.W.Board		
Resistors		
VR201	18E29473S01	VR, 50KBX2 (LEVEL)
VR202	18E29472S01	VR, 50KEX4 (FREQUENCY)
VR203	18E29474S01	VR, 20KDX2 (Q-FACTOR)
Connectors		
CB104	09E29478S01	CONN BASE, 53015-0610
CB105	09E29481S01	CONN BASE, 53015-1210
LED P.W.Board		
LED's		
LD801	48E29454S01	LED, YLRG-304M-5.5(GRN/RED)
LD802	48E29455S01	LED, YLRG-304M-5.5(GRN/YEL)
LD803	48E29454S01	LED, YLRG-304M-5.5(GRN/RED)
Capacitors		
C803	08E22510S01	CAP,CER,181-J-CP 50V
C804	08E22510S01	CAP,CER,181-J-CP 50V
C805	08E22510S01	CAP,CER,181-J-CP 50V

Symbol No.	Part No.	Description
Connector		
CH803	01E29467S01	CONN ASS'Y 7P
Miscellaneous		
ET501	29E29484S01	SPEAKER OUTPUT Terminal (CH-1)
ET502	29E29484S01	SPEAKER OUTPUT Terminal (CH-2)
ET801	29T25237Y01	POWER SUPPLY Terminal
F801	65E29465S01	Fuse, Auto 80A (For Battery Line)
FAN802	01E29562S01	DC-FAN
JK001	09E29483S01	Jack, RCA INPUT/OUTPUT

Exploded View (Cabinet)

1

2

3

4

5

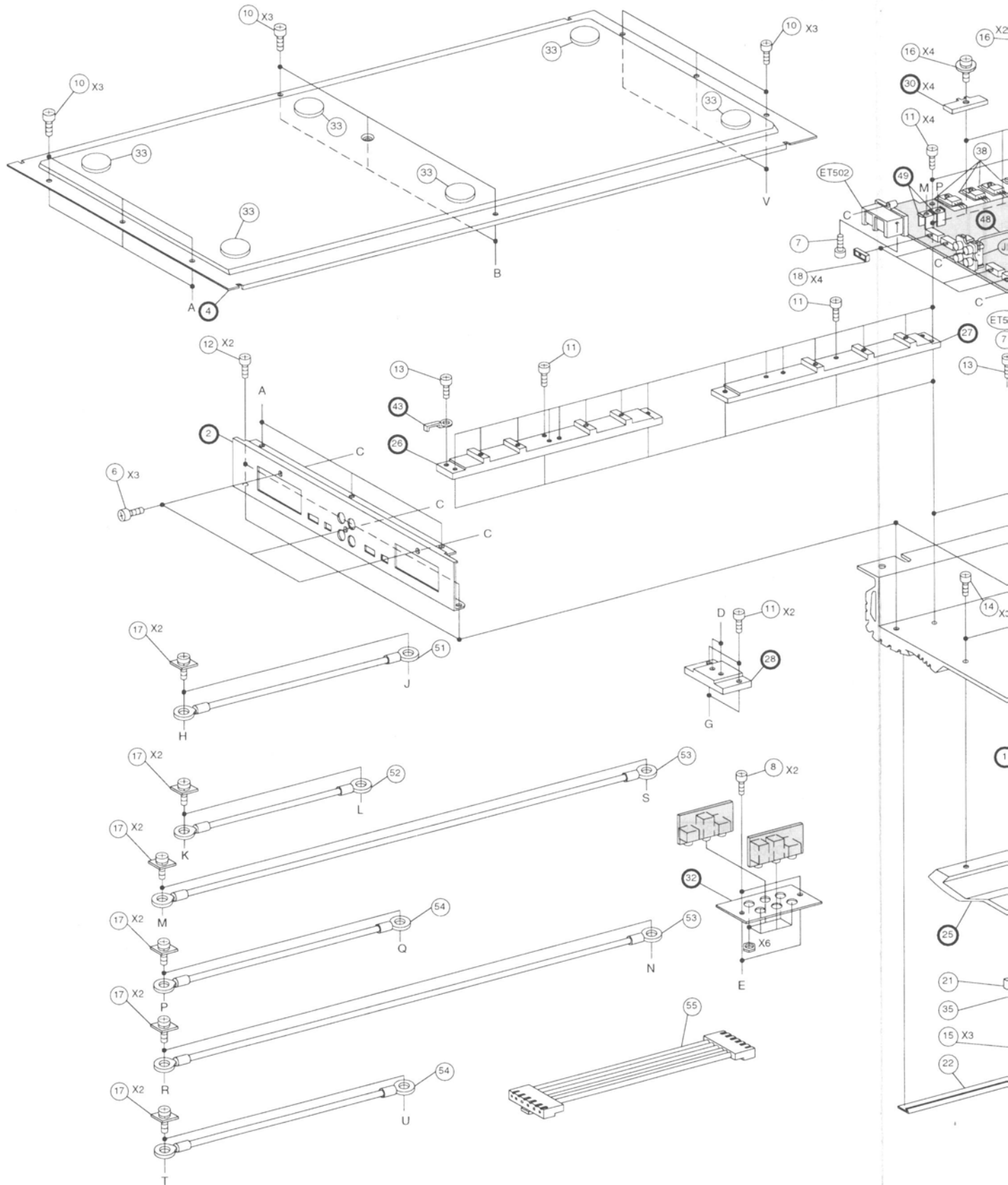

A

B - 39 -

C

D

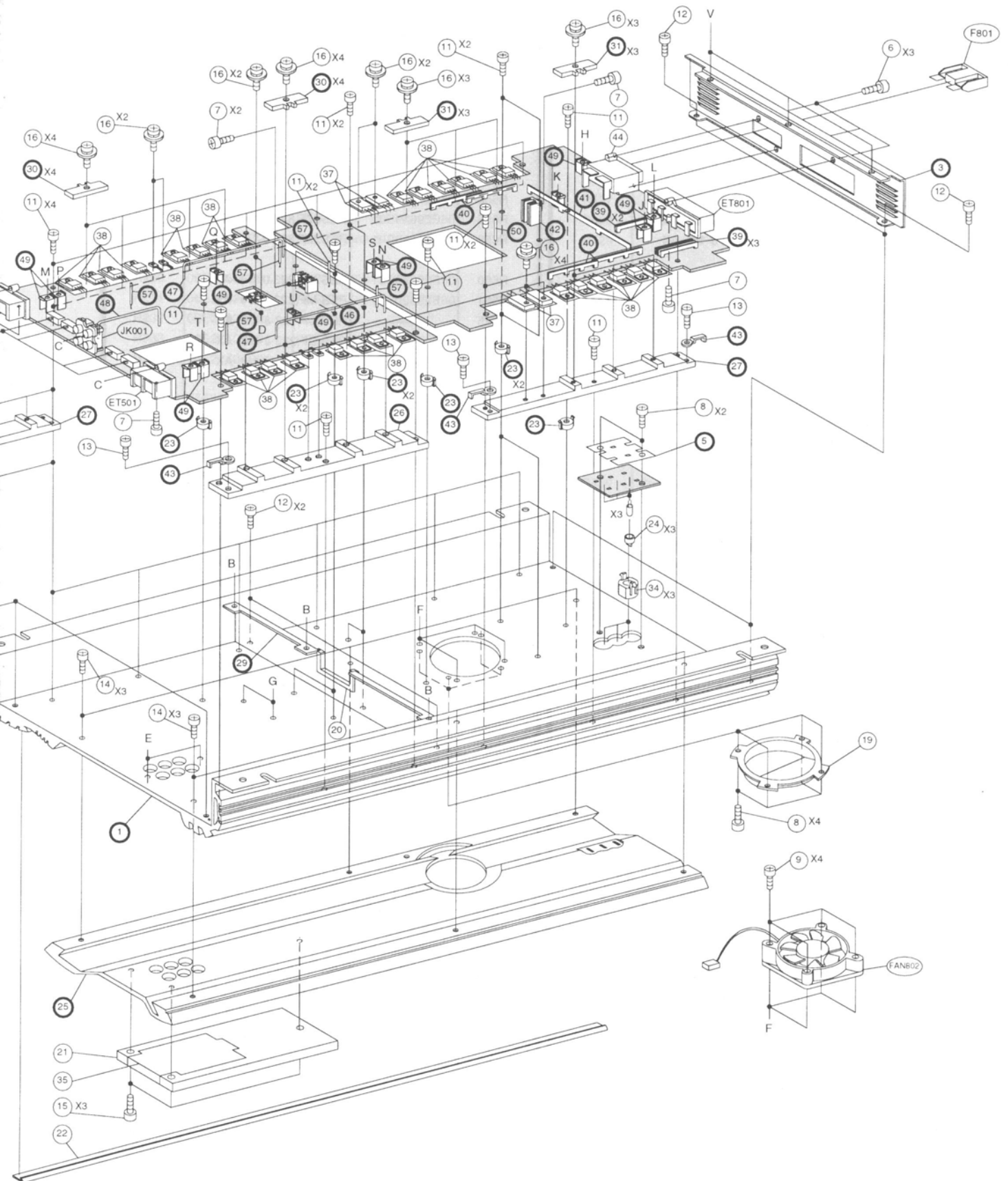

Cabinet Assembly Parts List

NOTE: Parts without part number are not supplied.

Symbol No.	Index	Part No.	Description	Symbol No.	Index	Part No.	Description
6		03E09416S09	Screw, TPG-TPT (M3X10)				
7		03E09416S10	Screw, TPG-TPT (M3X8)				
8		03E24424S01	Screw, TPG-TPT (M2.6X5)				
9	4-G	03E29523S01	Screw, TPG-TPT (M3X20)				
10		03E09417S05	Screw, MCH-TPT (M2.6X5)				
11		03E09417S06	Screw, TPG-TPT (M3X11)				
12		03E09417S08	Screw, TPG-TPT (M3X5)				
13		03E20920S01	Screw, TPG-TPT (M3X5)				
14		03E29348S01	Screw, TPG-TPT (M3X8)				
15	5-D	02E29524S01	Wrench, Bolt				
16		03E20922S01	Screw, TPG-TPT (M3X11)				
17		03E29525S01	Screw, MCH (M4X10)				
18	2-D	15E11445S01	Cover, Switch				
19	3-G	15E29526S01	Cover, Grill				
20	3-E	15E29527S01	Cover, Shield				
21	5-D	64E29528S01	Badge, V12 (EXPERT)				
22	5-D	15E29529S01	Cover, Plate				
24	3-G	61E29351S01	Lens, LED				
33		75E29531S01	Cushion, Rubber				
34	3-G	15E29379S01	Holder, LED				
35	5-D	64E29532S01	Scale Plate				
37		14E11487S01	Insulator, Sheet-B				
38		14E20977S01	Insulator, Sheet-A				
44	1-F	09T95463W01	Fuse, Holder				
51	3-B	01E29469S01	Assy., Battery Wire 100mm				
52	4-B	01E29470S01	Assy., Direct-Battery Wire 80mm				
53	4-C	28E29489S01	Output GND Wire 280mm				
54		28E29490S01	Output Power Wire 100mm				
55	5-C	01E29468S01	Assy., Connector Wire 80mm (6P-6P)				

ALPINE ELECTRONICS INC.

Tokyo Office : 1-1-8 Nishi Gotanda,
Shinagawa-ku, Tokyo, Japan 141-8501
Phone 03-3494-1101 Telex 8927-61

ALPINE ELECTRONICS OF AMERICA, INC.

19145 Gramercy Place
Torrance, California 90501
Phone 310-326-8000

ALPINE ELECTRONICS OF CANADA, INC.

Suite 203, 7300 Warden Ave. Markham,
Ontario L3R 9Z6, Canada
Phone 905-475-7280 Fax 905-474-9146

ALPINE ELECTRONICS GmbH

Brandenburger Str. 2-6,
4030 Ratingen F.R. Germany
Phone 001-49-2102-4550 Telex 8589157
Fax 001-49-2102-445321

3 / 99-S
68E29603S01
Printed in Japan